

Koken®



ENGLISH



GERMAN



FRENCH

2018-19

Koken TOOL CO., LTD.



INDEX

Reproduction in whole or in part without proper and prior authorization is prohibited.

Der Nachdruck, im ganzen oder auch auszugsweise, bedarf unserer ausdrücklichen, vorherigen Genehmigung.

La reproduction de ce catalogue en tout ou en partie sans autorisation préalable est interdite.

Specifications or designs of any product in this catalogue are subject to change without notice.

Wir behalten uns das Recht vor, jedes in diesem Katalog gezeigte Werkzeug, auch ohne vorherige Ankündigung, in Ausführung und Design ändern zu dürfen.

Nous nous réservons le droit de modifier les modèles et les dimensions des outils présentés dans ce catalogue et ce sans autre notification préalable.

Z-SERIES
Z-SERIE
SERIES Z

P20~34



HAND SOCKETS
STECKSCHLÜSSEL
DOUILLES

P36~126



TITAN-SOCKETS & ACCESSORIES
TITAN STECKSCHLÜSSEL UND ZUBEHÖRTEILE
DOUILLES ET ACCESSOIRES TITAN

P128



ACCESSORIES
ZUBEHÖRTEILE
ACCESSOIRES

P130~166



SCREWDRIVERS
SCHRAUBENDREHER
TOURNEVIS

P168~172



IMPACT SOCKETS
STECKSCHLÜSSEL P174~242
DOUILLES



MOTORCYCLE TOOLS
MOTORRAD WERKZEUGE P286~288
OUTILLAGE MOTO



SLEEVE-DRIVE SOCKETS
SLEEVE-DRIVE STECKSCHLÜSSEL P244~252
DOUILLES, SLEEVE DRIVE



TOOLS FOR CONSTRUCTION SITES
WERKZEUGE FÜR DAS BAUGEWERBE P290~295
OUTILLAGE POUR L'INDUSTRIE DU BÂTIMENT



SOCKETS WITH TURNABLE PLASTIC PROTECTORS
STECKSCHLÜSSEL MIT DREHBAREN SCHUTZHÜLSEN AUS KUNSTSTOFF P254~256
DOUILLES A PROTECTIONS PLASTIFIEES



SPARE PART SETS
ERSATZTEILSÄTZE P298~301
PIECES DE RECHANGE



INDUSTRIAL SOCKETS
STECKSCHLÜSSEL, INDUSTRIE-AUSFÜHRUNG P258~262
CLES A DOUILLES, FINISSAGE INDUSTRIEL



AUTOMOTIVE TOOLS
WERKZEUGE FÜR KFZ UND NUTZFAHRZEUGE P264~284
OUTILS POUR POIDS LOURDS ET VÉHICULES UTILITAIRES



By reading QR codes are shown in this catalogue you will find movies and more explanations of our tools.

Über die QR codes in diesem Katalog erhalten Sie Zugang zu Filmen mit zusätzlichen Erläuterungen zu unseren Werkzeugen.

A l'aide des QR codes dans ce catalogue vous avez accès à des films et explications supplémentaires de nos produits.



■ TEST AND LABORATORY
 ■ TESTLABOR
 ■ TEST AU LABORATOIRE



Ko-ken uses a variety of test equipment. Strength is measured by the Static Load Test Machine that can measure torque load up to 5,000Nm. Durability is measured by the Cyclic Test Machine and corrosion resistance testing is done by the Salt Spray Test Machine. The test results are used to improve our standard products and assist with new product design and development.

Wir verfügen über die verschiedensten Testgeräte:
 -Die Festigkeitseigenschaften der Werkzeuge werden mit einer statischen Drehmoment-Testmaschine, die Prüfdrehmomente bis 5.000Nm erzeugen kann, überprüft.
 -Die Dauerbelastbarkeit wird mit einer Testmaschine durchgeführt mit der die Werkzeuge zyklisch in langen Testreihen belastet werden.
 - Der Korrosionsschutz wird regelmäßig mittels Salzsprühnebelprüfung kontrolliert.
 Die gewonnenen Testergebnisse ermöglichen eine stetige Verbesserung der Standardwerkzeuge und helfen bei der Entwicklung neuer Produkte.

Ko-ken utilise plusieurs types de tests. La résistance est mesurée par une installation de test à charge statique d'une capacité de 5.000 Nm. La durée de vie est déterminée par une machine à cycles et la résistance à la corrosion par une installation à projection de sel.
 Les résultats de ces tests sont destinés à améliorer nos produits standards et à assister au développement de nouveaux produits.



■ DESIGN AND DEVELOPMENT
 ■ ENTWICKLUNG UND DESIGN
 ■ DESIGN ET DEVELOPPEMENT



The 3D-CAD is used to improve standard products, designing new products and making customized items for special requirements. Trial products are regularly developed, manufactured and tested to improve the durability, appearance and functionality of all tools produced by Ko-ken.

3D-CAD Programme helfen uns sowohl, bei der Weiterentwicklung unserer Standardwerkzeuge, als auch beim Designen neuer Produkte und beim Entwerfen von Sonderanfertigungen. Um die Zuverlässigkeit und Funktionalität unserer Werkzeuge zu verbessern, werden ständig Versuchswerkzeuge gefertigt.

La technique CAD-3D est utilisée pour l'amélioration des produits standards, le design des nouveaux produits et la réalisation d'outils spéciaux. Des séries d'essai sont régulièrement développées, fabriquées et testées pour améliorer l'apparence et la fonctionnalité de tous les produits Ko-ken.



■ FORGING
 ■ SCHMIEDEN
 ■ FORGEAGE



The Forming machines are used for the forging process. These machines can produce mass quantities of sockets and parts with high accuracy that ordinary drop forging machines can not achieve. On the other hand, ordinary forging machines are also used for small production runs.

Zum Schmieden verwenden wir eigene Umformmaschinen.

Diese Maschinen werden zur Produktion großer Stückzahlen von Steckschlüsseln und Betätigungswerkzeugen verwendet mit einer Genauigkeit, die mit normalen Gesenkschmiede Maschinen nicht gewährleistet werden kann.

Bei kleineren Fertigungsserien werden zur Fertigung auch kleinere Gesenkschmiedemaschinen verwendet.

Des machines de formage à froid sont utilisées. Ces machines peuvent produire en masse les douilles et accessoires avec une précision supérieure à la forge conventionnelle.

Toutefois, pour des petites séries, des machines à forger traditionnelles sont également utilisées.



■ TURNING
 ■ DREHEN
 ■ TOURNASAGE



The forged steel is turned into required shapes and dimensions. The MC (Machining Center) operates with extraordinary speed and precision. The article number, size, logo, production number, and MADE IN JAPAN are marked on the products after the turning process has been completed.

Der geschmiedete Stahl wird nun auf die endgültige Form abgedreht.

Unser Maschinenzentrum arbeitet hier mit außergewöhnlicher Geschwindigkeit und Präzision.

Nach dem Drehvorgang wird das Werkzeug mit Artikelnummer, Abmessung, Logo, Produktionsnummer und MADE IN JAPAN markiert.

Après la forge, les pièces sont usinées à la bonne dimension par tournage. Les centres d'usinage travaillent avec une précision et une vitesse extraordinaire.

Le numéro d'article, la dimension, le logo Ko-ken, un numéro de production ainsi que la mention « Made in Japan » sont gravés sur le produit après tournage.



■ HEAT TREATMENT
 ■ HÄRTEN
 ■ DURETE



To make the tools stronger and more durable, proper heat treatment is critically important. The temperature and the time of the heat treatment are strictly regulated by a very accurate control device.

Um die optimale Stabilität und Festigkeit der Werkzeuge zu erreichen ist der Härtingsprozess der Werkzeuge von höchster Wichtigkeit.

Die hohe Genauigkeit von Temperatur- und Dauer der Wärmebehandlung werden durch sehr genaue Regeleinrichtungen in den Härteöfen erreicht.

Pour la résistance et la dureté de l'outil, un traitement thermique adapté est indispensable. Les températures et la dureté de traitement sont très précisément contrôlées.



■ INSPECTION
 ■ MESSEN UND PRÜFEN
 ■ CONTRÔLE



Our products are periodically checked at each production process by inspection devices. Highly accurate 3-D measuring instruments are used to inspect and confirm dimensions.

Unsere Produkte werden periodisch nach jedem Produktionsprozess überprüft. Hierzu verwenden wir sehr genaue 3D Messgeräte.

Nos produits sont contrôlés périodiquement à chaque étape de leur fabrication.

Des instruments de mesure en 3D, très précis sont employés pour la vérification des dimensions.





FLAT DRIVE®

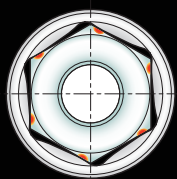

Flat Drive is designed to guarantee a flat surface contact between the socket and the bolt/nut.

The Flat contact reduces wear and allows to transmit a higher torque value.

The Flat Drive System is also used for the square drive end as well as the hexagonal or bi-hexagonal openings of the socket.



Das Flat Drive Design sorgt für die optimale Kraftübertragung zwischen den Flächen des Steckschlüssels und der Schraube. Dies erlaubt eine Übertragung von höheren Drehmomenten. Das Flat Drive System findet ebenfalls bei allen Antriebsvierkanten sowie bei 6-kant und 12-kant Profilen Verwendung.

Le profil Flat Drive garantit un contact optimal entre la douille et l'écrou. Ce contact « à plat » réduit l'usure et permet la transmission d'un couple plus élevé. Ce système Flat Drive est utilisé pour tous les carrés conducteurs ainsi que pour toutes nos douilles 6-pans et 12-pans.

SOCKETS STECKSCHLÜSSEL DOUILLES



NUT GRIP®



Twin balls at the 6-point opening hold bolt/nut tightly for safe and reliable work.

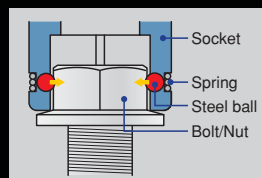

Die zwei Kugeln in der 6-kant Öffnung unserer NUT GRIP Steckschlüssel halten die Schraube sicher im Steckschlüssel. Dies erlaubt ein Arbeiten auch an schwer zugänglichen Stellen.

Les 2 billes dans l'ouverture du 6-pans de la douille retiennent l'écrou de manière sûre et efficace.

SURFACE DRIVE



Surface drive sockets are designed to retain contact with the flat sides of the nut in order to transmit higher torque and reduce nut wear.

These sockets are ideal for using on polished nuts, aluminum nuts and nuts with worn out points.

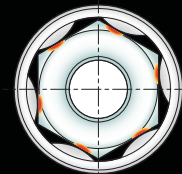

Das Profil unserer Surface-Drive Steckschlüssel greift die Schraube an deren Flächen.

Dies sichert eine höhere Kraftübertragung und verhindert ein Durchrutschen des Steckschlüssels. Diese Steckschlüssel eignen sich besonders für polierte Schrauben, Aluminium Schrauben und Schrauben bei denen die Ecken bereits abgerundet sind.

Notre profil Surface Drive assure le contact entre la douille et les plats de l'écrou. Ceci réduit l'usure et permet la transmission d'un couple plus élevé. C'est une solution idéale pour les écrous polies, celles en aluminium ou arrondies.

PATHFINDER®



The beveled flats of the 6-point opening of the PATHFINDER socket engage the nut almost immediately. PATHFINDER sockets are ideal for using with power tools in automatic assembly processes, as the power tool does not have to be totally stopped for the socket to engage the nut.

Da die Maschine nicht nach jedem Schraubvorgang angehalten werden muss, ergibt sich eine erhöhte Produktivität, die sich bei vollautomatischen Maschinen (Mehrschrauberschrauber) ganz besonders auswirkt.

Les parois en biais du 6-pans des douilles PATHFINDER assurent l'engagement quasi immédiat de l'écrou. Le fait de ne pas devoir arrêter la machine après chaque serrage procure un gain de productivité particulière appréciable dans les chaînes de montage automatiques.



RATCHET HANDLE KNARRENGRIFFE MANCHE À CLIQUET



J Type
Rubber Grip
Gummigriff
Manche en matière plastique



P-Type
Plain Grip
Glatter Griff
Manche lisse



N-Type
Knurled Grip
Gerändelter Griff
Manche moletée



S.O.D.H-System®

Two dogs are located in the ratchet body so that the dogs and springs are held securely in place, allowing the reversing lever and dog to switch smoothly.

The torque load on the gear is transmitted vertically to the dog, and in turn, down the ratchet handle. This mechanism

locks gears tightly in place while torque is being applied, thus avoiding any gear slippage.

Die zwei Sperrklinken sind fest im Knarrenkörper verankert, die Federn sind dadurch fest fixiert.

Die Umschaltung der Knarre erfolgt leicht und sicher.

Die Kraft des Knarrenzahnrad wird vertikal auf die Sperrklinken übertragen, dadurch wird das Überspringen des Knarrenmechanismus sicher vermieden.

Les 2 rochets sont insérés dans le corps du cliquet. De ce fait les ressorts sont également fermement fixés. L'inversion se produit sans à-coups. Ce mécanisme assure aussi une transmission du couple sans risque de ripage.



Two-Step Dog

Two flats hold two teeth of the ratchet gear, thus increasing the maximum torque load of the ratchet compared with a single-step system.

Die Kraft wird über zwei Zähne des Knarrenzahnrades übertragen. Dies erlaubt eine höhere Kraftübertragung gegenüber Knarren mit einem Zahn Mechanismus.

La force est transmise par les deux dents du mécanisme. Ceci permet un couple plus élevé par rapport aux systèmes à une seule dent .



Three-Step Dog

Two dogs are set in the same axis, and the three teeth hold the ratchet gear.

The enlarged contact area produces an about 10% higher torque value and the S.O.D.H-System provides smooth and light movements.

Die scharnierartig eingelagerten Sperrklinken haben jetzt jeweils drei Zähne im Eingriff. Die dadurch vergrößerte Greiffläche erhöht das maximale Drehmoment um ca. 10%. Auch diese Knarre besticht durch ihren leichten und geschmeidigen Lauf.

Les deux rochets étant placés sur le même axe, les trois dents de l'engrenage sont engagées en permanence. Ce système assure une augmentation de 10% du couple maximum admissible. Ce cliquet se caractérise également par son fonctionnement souple et sans à-coup.



SHAPE OF HANDLE
FORMGEBUNG DER GRIFFE
MODELE DE POIGNEE



OVAL SHAPE SHANK



Unique designed oval shape shank provides extra strength and durability.

Der einzigartige ovale Schaftquerschnitt in Belastungsrichtung erhöht die Stabilität und Widerstandsfähigkeit.

La section ovale, orientée dans le sens de l'effort, confère à cet outil une résistance et une durée de vie incomparable.



KNURLING



Rotation and general handling of extensions with oily hands is greatly improved with the **Koken** developed 6 point knurling. Also the **Koken** 6 point knurling stops the extensions from rolling around the work area.

Durch die von **Koken** entwickelte 6 fache Rändelung wird die Handhabung deutlich erleichtert.

Außerdem wird das Herumrollen der Verlängerungen wirksam verhindert.

La manipulation des rallonges est grandement facilitée par le profil moleté développé par **Koken**. Ce même profile empêche le roulement intempestif des rallonges sur le plan de travail.



WOBBLE-FIX



TWO WAY USAGE

- a) In a fixed position, as a normal extension bar
- b) In a half-fixed position, as a flexible extension bar providing a 15° angle operation.

Winkerverlängerungen lassen sich in zwei Einstellungen verwenden

- a) voll eingesteckt und starr
- b) halb eingesteckt, mit einem Arbeitswinkel von 15°.

Deux utilisations possibles

- a) comme rallonge normale, dans une position fixe
- b) comme une rallonge angulaire avec une possibilité d'inclinaison jusqu'à 15°

Fix

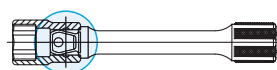

Wobble

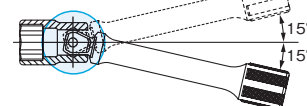



STUD BOLT PULLER / SETTER STEHBOLZENAUSDREHER UND STEHBOLZENSETZER EXTRACTEURS DE GOUJONS



STUD BOLT PULLER STEHBOLZENAUSDREHER DEGOUJONNEUSES



Hexagon body design can lessen the excessive load on cages and rollers inside the pullers.

Der neue Körper mit sechs Walzenmulden verteilt den Druck auf den Käfig und die Walzen weitaus vorteilhafter.

La forme hexagonale du corps améliore les tolérances.

Elle répartit l'effort de façon plus uniforme sur la cage et les rouleaux.



STUD BOLT SETTER STEHBOLZENSETZER MONTE-GOUJONS



A special socket for installing a stud bolt.

Inside steel ball prevent the stud bolt stuck onto the socket. After installing a stud bolt, turn to anti-clockwise to removing the socket.

Spezialwerkzeug zum Setzen von Stehbolzen. Der Bolzen trifft im Werkzeug nur auf den Stahlbolzen, was die Kontaktfläche verringert. Nach dem Setzen des Stehbolzens kann das Werkzeug im Linkslauf vom Stehbolzen abgezogen werden.

Douilles spéciales pour monter les goujons. Le goujon est en contact avec une bille d'acier pour l'empêcher d'adhérer à la douille.

Après avoir posé le goujon, tourner dans le sens antihorlogique pour le retirer

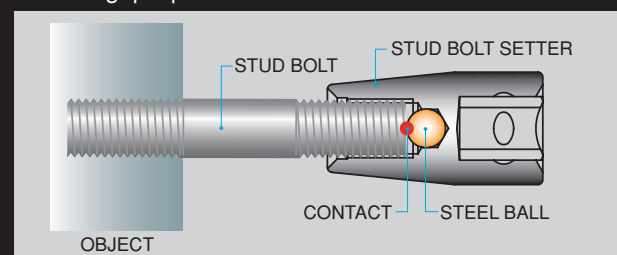



ATTACK DRIVER®

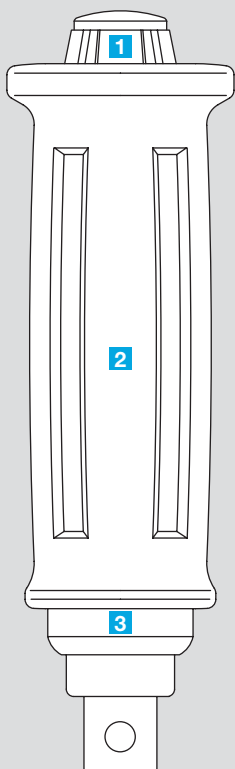

1 Black Finish - Schwarze Schlagplatte - Tête de frappe noire



Black finished head prevents peeling off the chrome plate by striking the head.
Der Schlagkopf wurde geschwärzt, um das Abblättern von Chrompartikeln zu verhindern.

La finition noire de la tête évite l'écailage du chrome lors de la frappe.



2 Original Body Shape - Einzigartige Formgebung - Forme unique du corps



Original design of the body achieved higher grip.

Die Gestaltung des Handschlagschrauberkörpers erhöht Führung und Griffigkeit des Werkzeuges.

Le dessin original du corps permet une meilleure prise en main de l'outil.

1 3 Heat Treatment - Wärmbehandlung - Traitement thermique

Special heat treatment is applied on the body. Hardness of striking part is slightly softer to prevent cracks.

On the other hand, Cam part converts the striking power to twisted by striking with hammer, therefore, this part is finished with higher hardness to improve anti-wear.

Besondere Aufmerksamkeit wurde der Wärmbehandlung des Körpers gewidmet, indem die Härte des Schlagendes leicht verringert wurde, um ein Reißen durch Hammerschläge zu vermeiden. Dagegen wurde die Härte und somit die Belastbarkeit in dem Teil des Körpers erhöht, wo der Schlag in Drehkraft umgesetzt wird.

Un traitement thermique spécifique est appliqué sur le corps de l'outil. La dureté des parties de frappe est légèrement inférieure pour diminuer le risque de casse. D'un autre côté, le mécanisme qui transforme la force de frappe en rotation est plus dure pour augmenter la résistance à l'usure.

3 Spring - Feder - Ressort

Stronger spring is adapted to convert the striking power efficiently to twisting power.

Eine extrem widerstandsfähige Feder sorgt für die unmittelbare Übertragung der Schlagkraft und ihre Umsetzung in wirksame Drehkraft.

Un ressort très résistant est monté sur l'outil pour convertir la force de frappe en force de torsion très efficace.





FREE-TURN GRIP



SPINNING CROSS WRENCH DREHBARER KREUZSCHLÜSSEL CLE EN CROIX RAPIDE



The shaft of cross wrench turns freely inside the knurled grip. The cross bar is removable for easy storage in a compact space.

Der Schaft des Kreuzschlüssels dreht sich frei in dem kordierten Griff. Die Querstange kann entnommen werden, das erlaubt eine platzsparende Aufbewahrung (z.B. im Fahrzeug)

La tige de la clé tourne librement dans sa poignée gaufrée. La barre transversale est démontable pour le rangement aisé de l'outil.



FLEXIBLE SPEEDER GELENKGRIF-FWINDE VILEBREQUIN RAPIDE

Free-turn grip allows speedy removal or replacement of wheel nuts. It can also be used as a hinge handle to tighten or loosen the nuts.

Der frei laufende Griff ermöglicht eine schnelle Radmontage. Das Werkzeug kann zusätzlich als Gelenkgriff verwendet werden.

La poignée à rotation libre permet l'enlèvement et la pose rapide des écrous de roue. Elle peut également être utilisée comme poignée articulée.



SPINNING SLIDE T-HANDLE FREILAUF T-GRIF-F POIGNEE EN T RAPIDE

The knurled grip is attached in the middle of shaft for free turning. Oval shaped cross bar prevents the bar from turning inside the shaft during use.

Der kordierte Freilauf-Griff befindet sich in der Mitte des Schaftes. Der Quergriff mit ovalem Querschnitt verhindert das Verrutschen.

La poignée gaufrée est fixée au milieu de la tige et est à rotation libre. La barre transversale est de forme ovale pour l'empêcher de tourner pendant l'utilisation.



IMPACT WHEEL NUT SOCKET IMPACT RADMUTTERN STECKSCHLÜSSEL DOUILLES POUR ÉCROUS DE ROUE, IMPACT



PLASTIC PROTECTOR KUNSTSTOFF HÜLSE PROTECTION EN PLASTIQUE



A detachable plastic protector is fitted to the socket to prevent damage to the wheel when working in tight areas.

The socket size and Ko-ken Mark printed on the shaft makes it easier to see if the socket is still rotating or stopped.

Zum Schutz empfindlicher Leichtmetallfelgen ist eine drehbare und abnehmbare Kunststoff Hülse an dem Steckschlüssel montiert. Die aufgedruckten Markierungen am Werkzeugschaft zeigen außerdem ob das Werkzeug steht oder rotiert.

La douille est pourvue d'un insert en plastique détachable. Il sert à prévenir tout dommage aux jantes lors de l'utilisation des douilles.

Le marquage sur la tige rend l'identification des douilles très facile.

EXTRA THIN-WALLED EXTRA DÜNNWANDIG PAROIS EXTRA MINCES



Thin-walled shape and 110mm length gives extra reach for nuts recessed deep inside the wheel.

They are ideal for aluminum wheel nuts where access to nut is very tight. Color coded shafts make size identification easy.

SPARK PLUG SOCKET ZÜNDKERZEN STECKSCHLÜSSEL DOUILLES AVEC RESSORTS RETENUE POUR BOUGIES



CLIP TYPE

This revolutionary new spark plug socket is designed to securely grip a spark plug at its hexagonal part by two stainless spring clips.

An internal brass guide holds the clips in place, which ensures perfect alignment of the spark plug into the threaded plughole of the cylinder head, thus preventing thread damage.

The brass guide also eliminates stress loading and possible damage to the ceramic insulator of the spark plug.

Zwei solide Federn aus rostfreiem Stahl fassen den Sechskant der Zündkerze und drücken ihn an den Anschlag der Messing-Führungsbuchse. Jetzt sitzt die Kerze genau senkrecht zur Achse des Steckschlüssels. Das Einschrauben kann ohne Beschädigung der Gewindegänge im Motorblock und ohne Druck auf den Isolator der Kerze erfolgen.

Deux puissants ressorts en acier inoxydable maintiennent la bougie sur sa partie hexagonale tout en l'appliquant contre la douille de guidage en laiton. L'alignement parfait de la bougie dans l'axe de l'outil permet à l'opérateur de poser celle-ci avec beaucoup de précision en réduisant au maximum les risques d'endommagement au filetage du bloc ainsi qu'à la partie en céramique de la bougie.

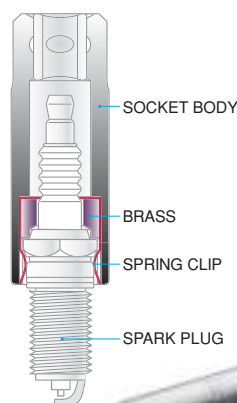

TORX® / TORXplus® & LHSTIX®

TORX®/TORXplus® and LHSTIX® are recognized as three of the most efficient fastening systems because of their ability to transfer greater torque, reduce end load and virtually eliminate tool slippage.

Durch die Fähigkeit größere Drehmomente zu übertragen sind TORX®/TORXplus® und LHSTIX® bekannt als die drei effizientesten Befestigungssysteme.

TORX®/TORXplus® et LHSTIX® sont reconnus comme étant trois systèmes de vissage particulièrement efficaces. Ils permettent en effet de transmettre des couples particulièrement élevés.

TORX® & TORX plus®



TORX® is a registered trademark of Acument Intellectual Properties, LLC.
 TORX® ist ein registriertes Markenzeichen der Firma Acument Intellectual Properties, LLC.
 TORX® est une marque déposée de Acument Intellectual Properties, LLC.
 TORXplus® is a registered trademark of Acument Intellectual Properties, LLC.
 TORXplus® ist ein registriertes Markenzeichen der Firma Acument Intellectual Properties, LLC.
 TORXplus® est une marque déposée de Acument Intellectual Properties, LLC.



Koken TOOL CO., LTD. holds the official license to use the trademark TORX®.
 Koken TOOL CO., LTD. hält die offizielle Lizenz um das Markenzeichen TORX® benutzen zu dürfen.
 Koken TOOL CO., LTD. est officiellement licencié pour l'usage de cette marque TORX®.
 Koken TOOL CO., LTD. holds the official license to use the trademark TORXplus®.
 Koken TOOL CO., LTD. hält die offizielle Lizenz um das Markenzeichen TORXplus® benutzen zu dürfen.
 Koken TOOL CO., LTD. est officiellement licencié pour l'usage de cette marque TORXplus®.

LHSTIX®

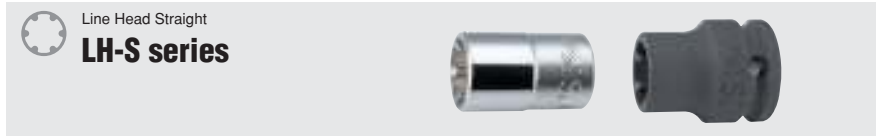

LHSTIX® is a registered trademark of OSG CORPORATION System Engineering Department.
 LHSTIX® ist ein registriertes Markenzeichen der Firma OSG CORPORATION System Engineering Department.
 LHSTIX® est une marque déposée de OSG CORPORATION System Engineering Department.
 Koken TOOL CO., LTD. holds the official license to use the trademark LHSTIX®.
 Koken TOOL CO., LTD. hält die offizielle Lizenz um das Markenzeichen LHSTIX® benutzen zu dürfen.
 Koken TOOL CO., LTD. est officiellement licencié pour l'usage de cette marque LHSTIX®.

Registered Trademarks / Eingetragene Warenzeichen / Marque déposée

Koken®



Koken TOOL CO., LTD.®

HIGH PERFORMANCE TOOLS OF CONVINCING QUALITY

山下工業研究所®

山下工研®

S.O.D.H-System®

Flatdrive®

ATTACK DRIVER®

HANDY-ENDY®

PATHFINDER®

Nut Grip®

LOCK NUT BUSTER®

NUT TWISTER®

BOLT TWISTER®



Warranty / Garantie / Garantie

WARRANTY

The trade mark **Koken** is your unqualified warranty against any defect in material or workmanship. Each **Koken** tool is built to more than meet the requirements of its intended use and is carefully checked before leaving the factory. Any **Koken** tool which fails because of defective material or workmanship will be repaired or replaced through your **Koken** dealer, to the exclusion of any further liability.

GARANTIE

Koken TOOL CO.,LTD. Shizuoka, Japan, garantit Ihnen die einwandfreie Qualität und Ausführung ihrer Produkte. Jedes Werkzeug der Marke **Koken** ist für Höchstleistungen konstruiert und wird vor Verlassen der Fabrik sorgfältig geprüft. **Koken** TOOL CO.,LTD. repariert oder ersetzt über ihre Händler unter Ausschluss jeglicher weitergehenden Haftung jedes fehlerhafte **Koken** Produkt kostenlos.

GARANTIE

La fabrique **Koken** TOOL CO.,LTD. Shizuoka, Japon, garantit la qualité irréprochable et le traitement absolument impeccable des outils portant la marque **Koken**. Chaque outil **Koken** quittant la fabrique est contrôlé soigneusement. La fabrique s'engage à réparer ou remplacer gratuitement tout défaut de matière ou de fabrication par l'intermédiaire de ses distributeurs, à l'exception d'une responsabilité étendue.

ISO9001







**SAFETY
ADVISER**

**SICHERHEITS-
RATGEBER**

**MESURES
DE SÉCURITÉ**

General / Allgemeines / Généralités

- (a) Make sure you use the right type socket, whose opening fit the nut.
Verwenden Sie immer den richtigen Steckschlüssel und überzeugen Sie sich davon, ob er auch auf die Mutter passt.
Utilisez toujours la bonne clé et assurez-vous qu'elle est rigoureusement adaptée à l'écrou.
- (b) For use on electric or air IMPACT Wrenches select IMPACT Sockets only.
Auf elektrischen oder pneumatischen Schlagschraubern dürfen nur hoch belastbare IMPACT-Steckschlüssel und Zubehörteile gesteckt werden.
Sur des vis à fixer par machines à chocs pneumatiques ou électriques n'utilisez que des clés à douille IMPACT et des accessoires IMPACT capables de résister à une haute sollicitation.
- (c) When using nut runners or IMPACT Wrenches wear safety goggles.
Tragen Sie bei der Anwendung von Schraubern stets eine Schutzbrille.
En opérant avec des visseuses et des machines à chocs, portez toujours des lunettes de protection.
- (d) Plastic or rubber handles are not intended to act as insulation.
Plastik-oder Gummigriffe stellen keinen Isolierschutz dar.
Les poignées en plastique ou en caoutchouc ne garantissent aucune isolation électrique.
- (e) Never substitute a HAND Socket for a INDUSTRIAL Socket or an IMPACT Socket, or a INDUSTRIAL Socket for an IMPACT Socket.
Nehmen Sie deshalb niemals anstelle eines INDUSTRIAL-oder IMPACT-Werkzeuges ein HAND-Werkzeug oder anstatt eines IMPACT-Werkzeuges ein INDUSTRIAL-Werkzeug.
Ne vous servez donc jamais d'un outil à main au lieu d'un outil INDUSTRIAL ou IMPACT ou d'un outil INDUSTRIAL au lieu d'un outil IMPACT.
- (f) Items in this catalogue marked  can be loaded to torque values which may cause breakage. In the interest of your own safety always apply load evenly and progressively to avoid breakage and possible injury.
Die mit  gekennzeichneten Artikel können bei Überbelastung zu Bruch gehen. Aus Gründen Ihrer eigenen Sicherheit sollten die betreffenden Werkzeuge nie ruckartig, sondern nach und nach belastet werden, um Bruch, und damit verbundene mögliche Verletzungen zu vermeiden.
Il est possible d'appliquer aux articles marqués  des couples de serrage susceptibles d'occasionner leur rupture. Pour votre propre sécurité, veuillez toujours appliquer la charge d'une manière uniforme et progressive. Ceci pour éviter ruptures et accidents.
- (g) Make sure to lock the impact sockets on driving tools with Pin / O-Ring or C-Ring.
Verwenden Sie Impact Steckschlüssel nie ohne Sicherungsring und Stift oder alternativ mittels unserer C-Ringe.
Ne jamais utiliser de douille à choc sans sécurité. (Anneau et goupille ou crochet en C)

Sockets / Steckschlüssel / Douilles

Sockets showing cracked walls, battered points or other marks of wear are to be replaced.

Steckschlüssel mit Haarrissen, abgestossenen Kanten oder mit anderen Verbraucherscheinungen sind umgehend zu ersetzen.

Les clés qui présentent des fissures capillaires, ou autres signes d'usure doivent être immédiatement changées.

Ratchets/Handles / Knarren/Griffe / Cliquets/Poignées

A ratchet is not a hammer.

Eine Knarre ist kein Hammer.

Un cliquet n'est pas un marteau.

Never use loose pipes or other improvised attachments on handles for increased leverage.

Setzen Sie niemals lose Rohre oder andere Hilfsstücke auf Steckschlüsselgriffe, um dadurch eine höhere Drehkraft zu erzeugen.

Ne mettez jamais de tubes ou autres pièces auxiliaires sur les poignées des clés à douille dans le but d'obtenir un couple de serrage plus élevé.

Extension Bars / Verlängerungen / Rallonges

The combination of several short extensions instead of one correct sized one is to be avoided.

Das Zusammenstecken von mehreren kurzen Verlängerungen als Ersatz für eine in der richtigen Länge ist unbedingt zu vermeiden.

Il faut absolument éviter d'utiliser plusieurs rallonges courtes au lieu d'une seule ayant la bonne longueur.

Adaptors / Verbindungsstücke / Réducteurs

Adaptors are to be used reasonably. Be reminded that high torque potentials are reached when using a "down" adaptor, a bigger sized handle to a smaller drive socket. Always stay within safe limits.

Reduzierstücke sind mit Vernunft einzusetzen. Beachten Sie, dass bei der Verwendung von Reduzierstücken hohe Drehmomentwerte ausgelöst werden nämlich dadurch, dass grössere Griffe auf kleinere Steckschlüssel gesetzt werden. Bleiben Sie jeweils innerhalb der Sicherheitsgrenzen.

Les réducteurs doivent être utilisés avec modération. Il est à considérer qu'avec les réducteurs on obtient un couple de serrage élevé du fait que des poignées plus grandes sont appliquées sur des clés à douille plus petites. Ne dépassez pas les limites de sécurité.

Koken

**Z-SERIES
Z-SERIE
SERIES-Z**



Z-Series : Feature



COMPACT

2400MZ and 3400MZ are designed 5-9mm shorter than standard 2400M and 3400M which is ideal for working in confined and tight areas.

2400MZ und 3400MZ sind gegenüber unseren Standardausführungen 2400M und 3400M um 5-9mm kürzer. Dies erlaubt ein Arbeiten an schwer zugänglichen Stellen.

Les douilles 2400MZ et 3400MZ étant plus courtes de 5-9mm par rapport aux douilles standards, elles ont l'avantage de faciliter le travail dans des endroits étroits et difficilement accessibles.

TOLERANCE-Hexagon Opening

The Hexagon openings of our Z-Sockets are produced with reduced tolerances (according to DIN/ISO) which achieve a more positive fit between bolt and socket.

Die Steckschlüsselöffnungen der Z-Serie werden mit geringeren Toleranzen (nach DIN/ISO) gefertigt um eine bessere, direktere Verbindung zwischen Schraube und Werkzeug zu gewährleisten.

Les douilles Ko-ken de la série Z sont fabriquées selon DIN/ISO comme toutes les douilles standards. Sauf que pour la série Z les tolérances sont plus restreintes afin d'atteindre un meilleur ajustement entre douille et vis.

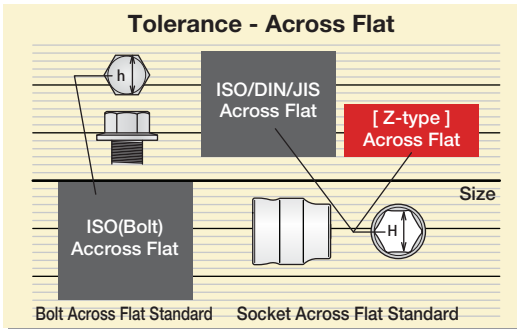

TOLERANCE-Square Drive

To ensure a tighter fit between socket and handle, the male and female square drives are produced with shorter tolerances (according DIN/ISO).

Auch die Antriebsvierkante sind mit einer geringeren Toleranz (nach DIN/ISO) gefertigt um eine festere Verbindung zwischen Betätigungswerkzeug und Steckschlüssel zu ermöglichen.

Aussi les carrés mâles et femelles sont fabriqués avec des tolérances plus restreintes (selon DIN/ISO) afin de garantir une meilleure fixation entre cliquet et douille.

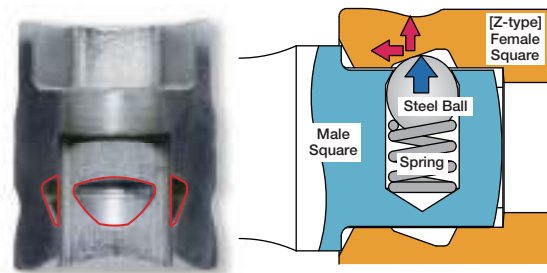
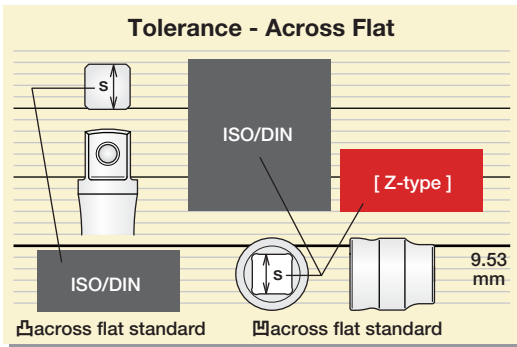

BALL HOLDING GROOVE

The inventive Ball Holding system of the Z-series allows a secure connection between Socket and Handle.

Die Werkzeuge der Z-Serie verfügen über spezielle Kugelfangrillen, die eine noch sicherere Verbindung zwischen Betätigungswerkzeug und Steckschlüssel gewährleisten.

La série Z dispose d'une rainure de fixation pour bille spéciale, qui améliore nettement la fixation entre douille et cliquet.

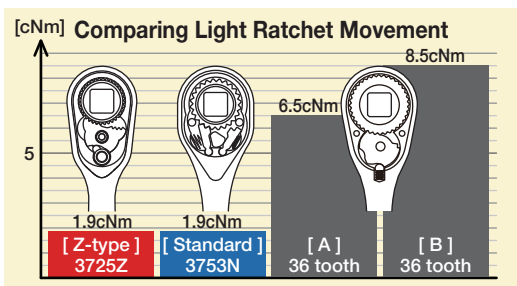

RATCHET HANDLE

Smaller head with 36 tooth gear and light ratchet movement allow working in narrow spaces and confined areas.

Der schmalere Knarrenkopf, mit leicht gängigem 36-Zahn Getriebe erlaubt ein Arbeiten an engen schwer zugänglichen Stellen.

La tête de cliquet réduit et un mécanisme à 36 dents plus léger facilite le travail dans des endroits difficilement accessibles.

* A, B : Other Brand

2400MZ (mm)	D ₁ (mm)	D ₂ (mm)	ℓ (mm)	L (mm)	(g)	(pcs.)
4	6.4	11	3	14	6	10
4.5	7	11	3	14	6	10
5	7.6	11	3	14	6	10
5.5	8.2	11	3.5	14	6	10
6	8.8	11	3.5	14	6	10
7	9.9	11	3.5	14	6	10
8	11.1	11.7	4.5	15	7	10
10	13.5	12.5	7	15	8	10
11	14.7	13.2	7	15	9	10
12	15.9	14.4	7	15	11	10
13	17.1	15.6	7	15	14	10
14	18.3	16.8	7	15	16	10

RS2400MZ/12	12 Pieces Set/Rail 200mm	(g)
4, 4.5, 5, 5.5, 6, 7, 8, 10, 11, 12, 13, 14		228

2300XZ (mm)	D ₁ (mm)	D ₂ (mm)	ℓ (mm)	H (mm)	L (mm)	(g)	(pcs.)
5.5	8.2	11	6	20	30	10	10
6	8.8	11	7	20	30	10	10
7	9.9	11	8	20	30	11	10
8	11.1	11.7	9	20	30	13	10
10	13.5	12.5	11	20	30	16	10
11	14.7	13.2	12	20	30	19	10
12	15.9	14.4	13	20	30	22	10
13	17.1	15.6	14	20	30	26	10
14	18.3	16.8	14	20	30	30	10

RS2300XZ/9	9 Pieces Set/Rail 200mm	(g)
5.5, 6, 7, 8, 10, 11, 12, 13, 14		290

2300MZ (mm)	D ₁ (mm)	D ₂ (mm)	ℓ (mm)	H (mm)	L (mm)	(g)	(pcs.)
4	6.4	11	5	41	50	14	10
4.5	7	11	5.5	41	50	16	10
5	7.6	11	6	41	50	16	10
5.5	8.2	11	6.5	41	50	16	10
6	8.8	11	7	41	50	17	10
7	9.9	11	8	41	50	20	10
8	11.1	11.7	9	41	50	22	10
10	13.5	12.5	11	41	50	29	10
11	14.7	13.2	12	41	50	33	10
12	15.9	14.4	13	41	50	40	10
13	17.1	15.6	14	41	50	45	10
14	18.3	16.8	16	41	50	51	10

RS2300MZ/12	12 Pieces Set/Rail 200mm	(g)
4, 4.5, 5, 5.5, 6, 7, 8, 10, 11, 12, 13, 14		445

2400MZ

6-point Sockets
6-kant Steckschlüssel
Douilles 6-pans

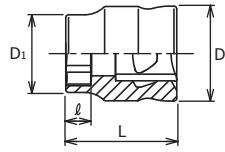

RS2400MZ/12

Socket Set on magnetic Rail
Steckschlüsselsatz auf Magnetschiene
Jeu de douilles sur rail à aimant



2300XZ

6-point Sockets, Semi-Deep
6-kant Steckschlüssel, mittel-lang
Douilles, semi-profondes 6-pans

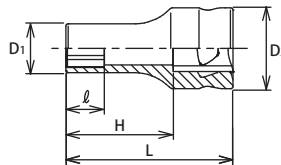

RS2300XZ/9

Socket Set on magnetic Rail
Steckschlüsselsatz auf Magnetschiene
Jeu de douilles sur rail à aimant



2300MZ

6-point Deep Sockets
6-kant-Steckschlüssel, lang
Douilles longues 6-pans

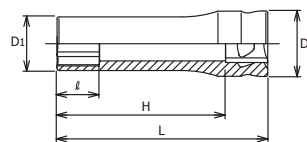

RS2300MZ/12

Socket Set on magnetic Rail
Steckschlüsselsatz auf Magnetschiene
Jeu de douilles sur rail à aimant



2000Z-28/-50

 Phillips Bit Sockets
Steckschlüssel für Kreuzschlitzschrauben Phillips
Douilles tournevis pour vis à empreinte Phillips

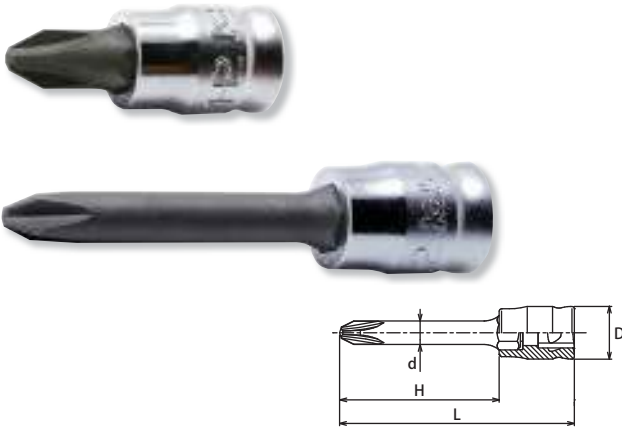

2000Z-28 (PH)	D (mm)	H (mm)	L (mm)	(g)	(pcs.)
1	11.2	12	28	9	10
2	11.2	12	28	10	10
3	11.2	12	28	10	10

2000Z-50 (PH)	D (mm)	d (mm)	H (mm)	L (mm)	(g)	(pcs.)
1	11.2	4	34	50	11	10
2	11.2	5	34	50	13	10
3	11.2	-	34	50	16	10

2005Z-25

 Bit Sockets for Slotted Head
Steckschlüssel für Schlitzschrauben
Douilles tournevis pour vis à fente



2005Z-25	T x W (mm)	D (mm)	H (mm)	L (mm)	(g)	(pcs.)
5	1.0 x 5.5	11.2	9	25	9	10
6	1.2 x 6.5	11.2	9	25	10	10

2010MZ-25/-50

 Inhex Bit Sockets
Steckschlüssel für Innensechskant-Schrauben
Douilles tournevis pour vis 6-pans creux

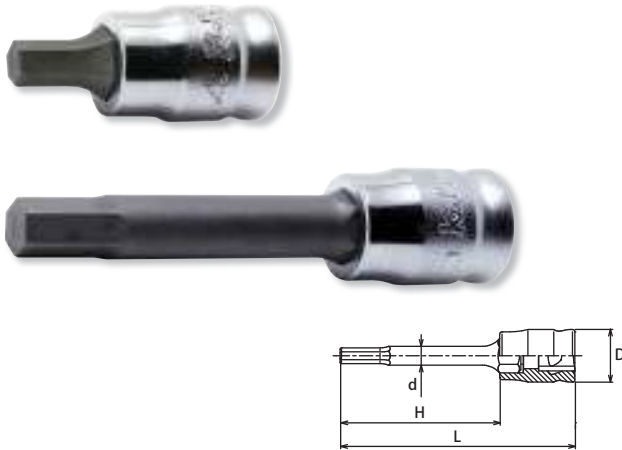

2010MZ-25 (mm)	D (mm)	H (mm)	L (mm)	(g)	(pcs.)
3	11.2	9	25	9	10
4	11.2	9	25	9	10
5	11.2	9	25	10	10
6	11.2	9	25	10	10

2010MZ-50 (mm)	D (mm)	d (mm)	H (mm)	L (mm)	(g)	(pcs.)
3	11.2	4	34	50	11	10
4	11.2	5	34	50	13	10
5	11.2	6	34	50	15	10
6	11.2	-	34	50	17	10

RS20XXZ/9

 Socket Set on magnetic Rail
Steckschlüsselsatz auf Magnetschiene
Jeu de douilles sur rail à aimant



RS20XXZ/9		9 Pieces Set/Rail 200mm	(g)
2000Z.28		1, 2, 3	213
2005Z.25		5, 6	
2010MZ.25		3, 4, 5, 6	

1/4"

Z-series
Z-serie
Series-Z

2025Z-28 (T)	D (mm)	H (mm)	L (mm)	(g)	(pcs.)
T10	11.2	12	28	9	10
T15	11.2	12	28	9	10
T20	11.2	12	28	9	10
T25	11.2	12	28	10	10
T27	11.2	12	28	10	10
T30	11.2	12	28	10	10
T40	11.2	12	28	11	10

2025Z-50 (T)	D (mm)	d (mm)	H (mm)	L (mm)	(g)	(pcs.)
T10	11.2	4	34	50	11	10
T15	11.2	4	34	50	11	10
T20	11.2	4.5	34	50	12	10
T25	11.2	5	34	50	13	10
T27	11.2	5	34	50	13	10
T30	11.2	5.6	34	50	15	10
T40	11.2	-	34	50	17	10

2025Z-28/-50

 TORX® Bit Sockets
TORX® Bit-Steckschlüssel
Douilles tournevis, TORX®

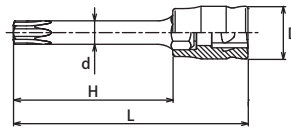

RS2025Z/7-L28	7 Pieces Set/Rail 200mm	(g)
T10, T15, T20, T25, T27, T30, T40		195

RS2025Z/7-L50	7 Pieces Set/Rail 200mm	(g)
T10, T15, T20, T25, T27, T30, T40		220

RS2025Z/7-L28 RS2025Z/7-L50

 Socket Set on magnetic Rail
Steckschlüsselsatz auf Magnetschiene
Jeu de douilles sur rail à aimant



2725Z 2725Z-160

Reversible Ratchet
Knarre, verstellbar
Cliquet, réversible

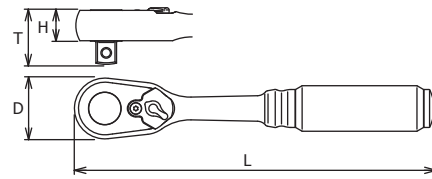

36

	D (mm)	T (mm)	H (mm)	L (mm)	(g)	(pcs.)
2725Z	20.5	17.1	9.5	114	79	2
New 2725Z-160	20.5	17.1	9.5	160	120	1

* Renewal Kits → 2725RK → P298

2726Z 2726Z-160

Flexible Ratchet, Reversible (Short)
Gelenk-Knarre kurz, verstellbar
Cliquet articulé court, réversible

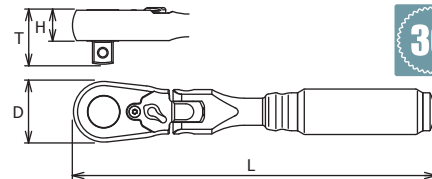

36
Flexible Head

	D (mm)	T (mm)	H (mm)	L (mm)	(g)	(pcs.)
2726Z	20.5	17.1	9.5	114	103	2
New 2726Z-160	20.5	17.1	9.5	160	150	1

* Renewal Kits → 2725RK → P298

2760Z

Extension Bars
Verlängerungen
Rallonges

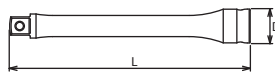

2760Z	D (mm)	L (mm)	(g)	(pcs.)
50	11.5	50	21	10
100	11.5	100	39	10
150	11.5	150	58	10

2771Z

Universal Joint
Gelenk-Einsatz
Joint articlé

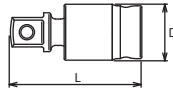

2771Z	D (mm)	L (mm)	(g)	(pcs.)
2771Z	11.7	29.9	15	10

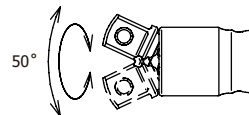

2772Z

Universal Double Joint
Doppelgelenk-Einsatz
Joint articlé double

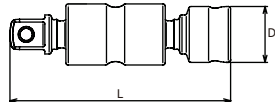

New 2772Z	D (mm)	L (mm)	(g)	(pcs.)
2772Z	11.7	46	26	10

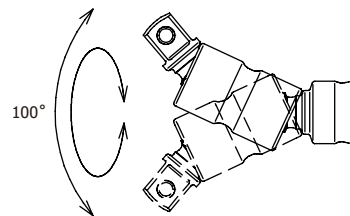

2756Z

Quick Spinner
Rändel-Drehscheibe
Lanceur

2756Z-3/8







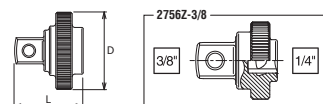

Quick Spinner, Adaptor
Rändel-Drehscheibe als Adaptor
Lanceur, adaptateur



2756Z-3/8



	D (mm)	L (mm)	(g)	(pcs.)
2756Z	20.3	18	15	10
2756Z-3/8	20.3	21.5	24	10

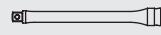

P2285Z		26 Pieces Set/△=660g	
PLASTIC CASE:W245xH120xT45			
Sockets	Accessories		
 2400MZ 6-pt. Sockets 4, 4.5, 5, 5.5, 6, 7, 8, 10, 11,12, 13, 14		2725Z	
		2756Z	
 2000Z.28 1, 2, 3		2771Z	
 2005Z.25 5, 6		2760Z-50	
 2010MZ.25 3, 4, 5, 6		2760Z-150	





P2285Z Set in PE-foam tray
Steckschlüsselsatz in Weichschaumeinlage
Set disposé dans boîte de rangement en mousse souple



2285ZE		10 Pieces Set/△=300g	
Rail 200mm/PLASTIC BAG			
Sockets	Accessories		
 2400MZ 6-pt. Sockets 5.5, 6, 7, 8, 10, 12, 13, 14		2725Z	
		2756Z	

2285ZE Socket Sets
Steckschlüssel Sätze
Jeu de clés à douilles

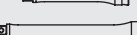

New 2286Z		17 Pieces Set/△=780g	
BLACK METAL CASE:W240xH100xT32mm			
Sockets	Accessories		
 2400MZ 6-pt. Sockets 4, 5, 5.5, 6, 7, 8, 10, 11, 12, 13, 14		2725Z	
		2756Z	
		2771Z	
		2760Z-50	
		2760Z-100	
		2760Z-150	

2286Z Set in PE-foam tray
Steckschlüsselsatz in Weichschaumeinlage
Set disposé dans boîte de rangement en mousse souple



3400MZ



6-point Sockets
6-kant Steckschlüssel
Douilles 6-pans

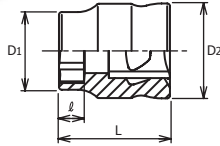

3400MZ (mm)	D ₁ (mm)	D ₂ (mm)	ℓ (mm)	L (mm)	(g)	(pcs.)
5.5	8.5	17	3.5	19	16	10
6	9.1	17	3.5	19	17	10
7	10.3	17	3.5	19	17	10
8	11.5	17	4.5	20	17	10
10	14	17	4.5	20	18	10
11	15.3	17	5.5	21	18	10
12	16.5	17	5.5	21	19	10
13	17.8	17	8.5	21	19	10
14	19	17	8.5	21	20	10
15	20.2	18.2	8.5	21	24	10
16	21.3	19.3	8.5	21	28	10
17	22.5	20.5	8.5	21	32	10
18	23.6	21.6	9.5	22	38	10
19	24.8	22.8	9.5	22	41	10
21	27	25	10.5	23	51	10
22	28.3	26.3	10.5	23	58	10

3400MZ is designed 5-9mm shorter than standard 3400M.
Ideal for working in confined and tight areas.

RS3400MZ/8 RS3400MZ/12



Socket Set on magnetic Rail
Steckschlüsselsatz auf Magnetschiene
Jeu de douilles sur rail à aimant



RS3400MZ/8	8 Pieces Set/Rail 200mm	(g)
8, 10, 11, 12, 13, 14, 17, 19		320

RS3400MZ/12	12 Pieces Set/Rail 300mm	(g)
7, 8, 10, 11, 12, 13, 14, 15, 16, 17, 18, 19		490

3300XZ



6-point Sockets, Semi-Deep
6-kant Steckschlüssel, mittel-lang
Douilles, semi-profondes 6-pans

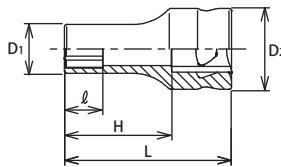

3300XZ (mm)	D ₁ (mm)	D ₂ (mm)	ℓ (mm)	H (mm)	L (mm)	(g)	(pcs.)
7	10.3	17	8	23	35	23	10
8	11.5	17	9	23	35	24	10
10	14	17	11	23	35	26	10
11	15.3	17	12	23	35	28	10
12	16.5	17	13	23	35	29	10
13	17.8	17	14	23	35	32	10
14	19	17	16	23	35	34	10
15	20.2	18.2	16	23	35	40	10
16	21.3	19.3	16.5	23	35	45	10
17	22.5	20.5	16.5	23	35	50	10
18	23.6	21.6	16.5	23	35	56	10
19	24.8	22.8	18	23	35	60	10

RS3300XZ/8 RS3300XZ/12



Socket Set on magnetic Rail
Steckschlüsselsatz auf Magnetschiene
Jeu de douilles sur rail à aimant



RS3300XZ/8	8 Pieces Set/Rail 200mm	(g)
8, 10, 11, 12, 13, 14, 17, 19		420

RS3300XZ/12	12 Pieces Set/Rail 300mm	(g)
7, 8, 10, 11, 12, 13, 14, 15, 16, 17, 18, 19		630

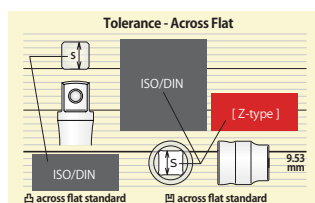
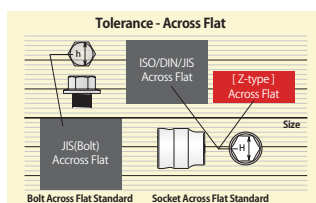

Manufacturing tolerance is precisely controlled to achieve a secure fitting.

BALL HOLDING GROOVE

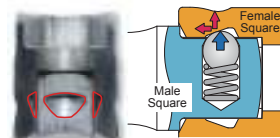

The inventive Ball Holding system of the Z-series allows a secure connection between Socket and Handle.

Die Werkzeuge der Z-Serie verfügen über spezielle Kugelfangrillen, die eine noch sicherere Verbindung zwischen Betätigungswerkzeug und Steckschlüssel gewährleisten.

La série Z dispose d'une rainure de fixation pour bille spéciale, qui améliore nettement la fixation entre douille et cliquet.

3300MZ (mm)	D ₁ (mm)	D ₂ (mm)	ℓ (mm)	H (mm)	L (mm)	(g)	(pcs.)
7	10.3	17	8	41.5	55	29	10
8	11.5	17	9	41.5	55	34	10
10	14	17	11	41.5	55	43	10
11	15.3	17	12	41.5	55	45	10
12	16.5	17	13	41.5	55	49	10
13	17.8	17	14	41.5	55	52	10
14	19	17	16	41.5	55	55	10
15	20.2	18.2	16	40.5	55	65	10
16	21.3	19.3	17	40.5	55	74	10
17	22.5	20.5	18	40.5	55	83	10
18	23.6	21.6	19	39.5	55	90	10
19	24.8	22.8	20	39.5	55	95	10

RS3300MZ/8	8 Pieces Set/Rail 200mm	(g)
8, 10, 11, 12, 13, 14, 17, 19		600

RS3300MZ/12	12 Pieces Set/Rail 300mm	(g)
7, 8, 10, 11, 12, 13, 14, 15, 16, 17, 18, 19		900

RS3X00MZ/12	12 Pieces Set/Rail 300mm	(g)
3400MZ	8, 10, 11, 12, 13, 14, 17, 19	550
3300MZ	8, 10, 12, 14	

3300CZ (mm)	D (mm)	ℓ (mm)	L (mm)	(g)	(pcs.)
14	18.4	11	70	67	10
16	20.5	13	70	71	10
18	22.9	12	70	75	10
20.8	26.3	13.5	70	105	10

Slim & light weight body with smaller outside diameter for work in tight spaces.

3305PZ (mm)	D (mm)	ℓ (mm)	L (mm)	(g)	(pcs.)
14	17.9	8	70	56	10
16	20	8	70	55	10

Spark Plug Socket with Magnet, 12-pt. opening: size 14mm



3300MZ

6-point Deep Sockets
6-kant-Steckschlüssel, lang
Douilles longues 6-pans

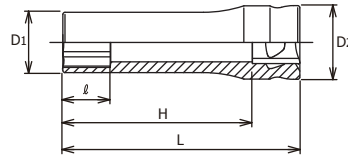

RS3300MZ/8

Socket Set on magnetic Rail
Steckschlüsselsatz auf Magnetschiene
Jeu de douilles sur rail à aimant

RS3300MZ/12



RS3X00MZ/12

Socket Set on magnetic Rail
Steckschlüsselsatz auf Magnetschiene
Jeu de douilles sur rail à aimant



3300CZ

Spark Plug Sockets with Spring Clips
Zündkerzen-Schlüssel mit Haltefeder
Douilles avec ressorts de retenues pour bougies

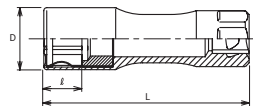

3305PZ

Spark Plug Socket with Magnet, 12-pt. opening
Zündkerzensteckschlüssel mit Magnet, 12-kant
Douille pour bougies, avec aimant, 12-pans

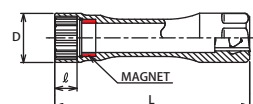

3010MZ-50/-75



Inhex Bit Sockets
Steckschlüssel für Innsechskant-Schrauben
Douilles tournevis pour vis 6-pans creux

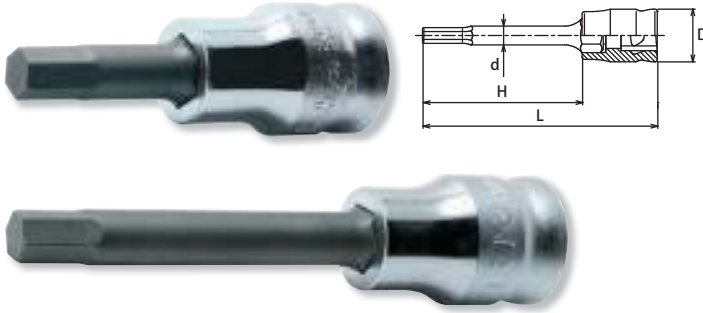

3010MZ-50 (mm)	D (mm)	d (mm)	H (mm)	L (mm)	(g)	(pcs.)
3	17	4	23.5	50	28	10
4	17	5	23.5	50	29	10
5	17	6	23.5	50	30	10
6	17	7	23.5	50	35	10
7	17	-	23.5	50	38	10
8	17	-	23.5	50	40	10
10	17	-	23.5	50	50	10
12	19	-	23.5	50	70	10

3010MZ-75 (mm)	D (mm)	d (mm)	H (mm)	L (mm)	(g)	(pcs.)
3	17	6	48.5	75	33	10
4	17	6	48.5	75	35	10
5	17	6	48.5	75	36	10
6	17	7	48.5	75	41	10
7	17	7.9	48.5	75	45	10
8	17	-	48.5	75	48	10
10	17	-	48.5	75	65	10
12	19	-	48.5	75	90	10

RS3010MZ/8-L50 RS3010MZ/8-L75



Socket Set on magnetic Rail
Steckschlüsselsatz auf Magnetschiene
Jeu de douilles sur rail à aimant



RS3010MZ/8-L50	8 Pieces Set/Rail 200mm	(g)
3, 4, 5, 6, 7, 8, 10, 12		460

RS3010MZ/8-L75	8 Pieces Set/Rail 200mm	(g)
3, 4, 5, 6, 7, 8, 10, 12		530

3025Z-50/-75



TORX® Bit Sockets
TORX® Bit-Steckschlüssel
Douilles tournevis, TORX®

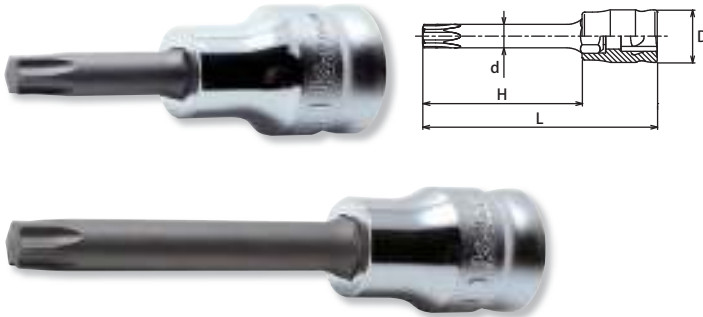

3025Z-50 (T)	D (mm)	d (mm)	H (mm)	L (mm)	(g)	(pcs.)
T10	17	3	23.5	50	27	10
T15	17	3.5	23.5	50	28	10
T20	17	3.9	23.5	50	28	10
T25	17	4.5	23.5	50	29	10
T27	17	5	23.5	50	30	10
T30	17	5.6	23.5	50	31	10
T40	17	6.7	23.5	50	35	10
T45	17	7.83	23.5	50	38	10
T50	17	8.90	23.5	50	48	10
T55	19	11.3	23.5	50	70	10

3025Z-75 (T)	D (mm)	d (mm)	H (mm)	L (mm)	(g)	(pcs.)
T20	17	4.5	48.5	75	32	10
T25	17	5	48.5	75	33	10
T27	17	5	48.5	75	33	10
T30	17	5.6	48.5	75	35	10
T40	17	6.7	48.5	75	41	10
T45	17	7.9	48.5	75	45	10
T50	17	8.9	48.5	75	55	10
T55	19	11.3	48.5	75	80	10

RS3025Z/8-L50 RS3025Z/8-L75



Socket Set on magnetic Rail
Steckschlüsselsatz auf Magnetschiene
Jeu de douilles sur rail à aimant



RS3025Z/8-L50	8 Pieces Set/Rail 200mm	(g)
T20, T25, T27, T30, T40, T45, T50, T55		450

RS3025Z/8-L75	8 Pieces Set/Rail 200mm	(g)
T20, T25, T27, T30, T40, T45, T50, T55		480

3/8"

Z-series
Z-serie
Series-Z

Z-SERIES
HAND
TITANIUM
ACCESSORIES
SCREWDRIVERS
IMPACT
SLEEVE-DRIVE
PROTECTOR
INDUSTRIAL
AUTOMOTIVE
MOTORCYCLE
CONSTRUCTION
SPARE PART

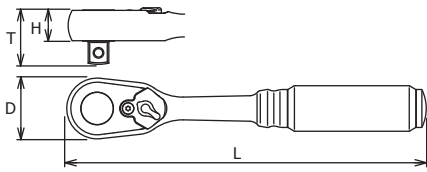

36

	D (mm)	T (mm)	H (mm)	L (mm)	(g)	(pcs.)
2725Z-3/8	20.5	20.5	9.5	114	83	2

2725Z-3/8 Reversible Ratchet Short
Knarre kurz, verstellbar
Cliquet court, réversible

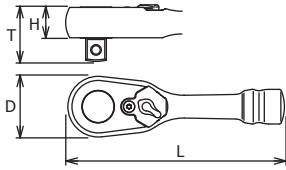

36

	D (mm)	T (mm)	H (mm)	L (mm)	(g)	(pcs.)
3725ZS	28	24.5	13.7	100	157	2

* Renewal Kits → 3725RK → P298

3725ZS Reversible Ratchet Short
Knarre kurz, verstellbar
Cliquet court, réversible

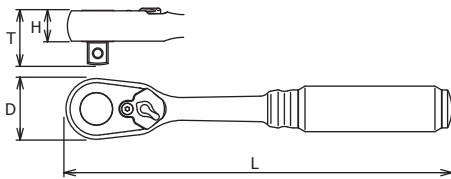

36

	D (mm)	T (mm)	H (mm)	L (mm)	(g)	(pcs.)
3725Z	28	24.5	13.7	178	254	1
New 3725Z-280	28	24.5	13.7	280	360	1

* Renewal Kits → 3725RK → P298

3725Z
3725Z-280 Reversible Ratchet
Knarre, verstellbar
Cliquet, réversible

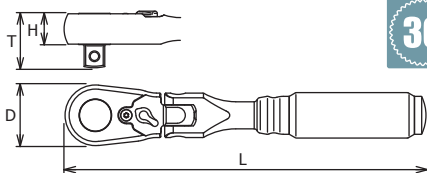

36 Flexible Head

	D (mm)	T (mm)	H (mm)	L (mm)	(g)	(pcs.)
2726Z-3/8	20.5	20.5	9.5	114	107	2

2726Z-3/8 Flexible Ratchet, Reversible (Short)
Gelenk-Knarre kurz, verstellbar
Cliquet articulé court, réversible



Z-SERIES
HAND
TITANIUM
SCREWDRIVERS ACCESSORIES
IMPACT
SLEEVE-DRIVE
PROTECTOR
INDUSTRIAL
AUTOMOTIVE
MOTORCYCLE
CONSTRUCTION
SPARE PART

3726ZS

Flexible Ratchet, Reversible (Short)
Gelenk-Knarre kurz, verstellbar
Cliquet articulé court, réversible

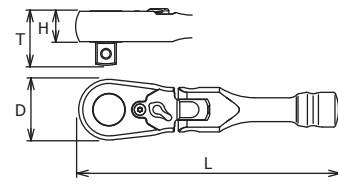

	D (mm)	T (mm)	H (mm)	L (mm)	(g)	(pcs.)
3726ZS	28	24.5	13.7	120	196	2

* Renewal Kits → 3725RK → P298

3726Z 3726Z-280

Flexible Ratchet, Reversible
Gelenk-Knarre, verstellbar
Cliquet articulé, réversible

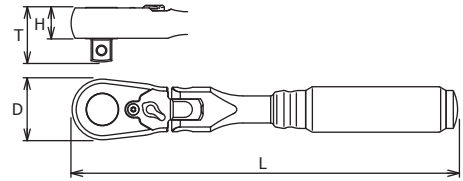

	D (mm)	T (mm)	H (mm)	L (mm)	(g)	(pcs.)
3726Z	28	24.5	13.7	178	317	1
New 3726Z-280	28	24.5	13.7	280	420	1

* Renewal Kits → 3725RK → P298

3768Z-250/-400

Hinge Handle
Gelenkgriff
Poignée articulée

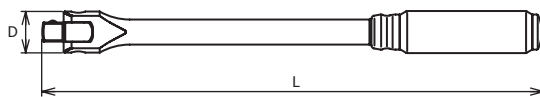

	D (mm)	L (mm)	(g)	(pcs.)
3768Z				
250	20.5	250	309	2
New 400	20.5	400	500	2

* Renewal Kits → 3768ZRK → P300

3760Z-75/-125/-250

Extension Bars
Verlängerungen
Rallonges

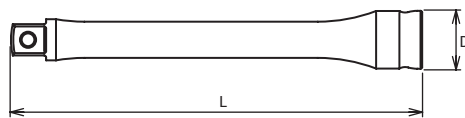

	D (mm)	L (mm)	(g)	(pcs.)
3760Z				
75	17.5	75	66	10
125	17.5	125	103	10
250	17.5	250	195	5

	D (mm)	L (mm)	(g)	(pcs.)
3771Z	18	42.5	44	10

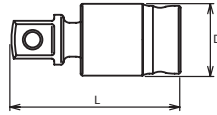
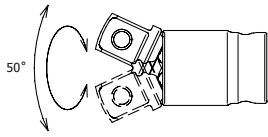

3771Z Universal Joint
Gelenk-Einsatz
Joint articlé

	D (mm)	L (mm)	(g)	(pcs.)
3772Z	17	65	76	10

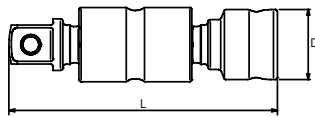
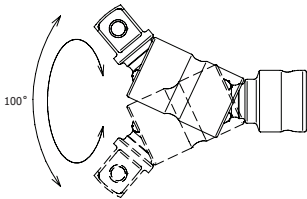

3772Z Universal Double Joint
Doppelgelenk-Einsatz
Joint articlé double

	D (mm)	L (mm)	(g)	(pcs.)
3756Z	28	25	40	10

Outside diameter is smaller compared to standard 3756.
Ideal for working in combination with 3725Z



3756Z Quick Spinner
Rändel-Drehscheibe
Lanceur

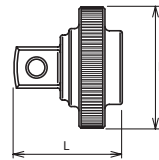

	D (mm)	L (mm)	(g)	(pcs.)
3756ZS	20.3	25	26	10

Ideal for working in combination with 2725Z-3/8 and 2726Z-3/8.

3756ZS Quick Spinner
Rändel-Drehscheibe
Lanceur

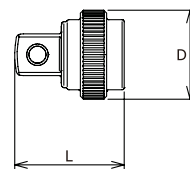

	D (mm)	L (mm)	(g)	(pcs.)
3322AZ-75	17.5	75	42	10

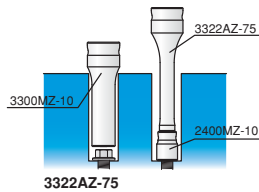

3322AZ-75 Extension Adaptor
Verlängerungsadapter
Reduction adapteur-rallonge



3286Z 21 Pieces Set/2.600g

BLACK METAL CASE:W415xH120xT50mm

Sockets	Accessories
3400MZ 6-pt. Sockets 7, 8, 10, 11, 12, 13, 14, 15, 16, 17, 18, 19, 21, 22	3725Z
	3756Z
	3771Z
	3768Z-250
	3760Z-75
	3760Z-125
	3760Z-250

3286Z Set in PE-foam tray
Steckschlüsselsatz in Weichschaumeinlage
Set disposé dans boîte de rangement en mousse souple



Z-series
Z-serie
Series-Z

3/8"

Z-SERIES

HAND

TITANIUM

ACCESSORIES

SCREWDRIVERS

IMPACT

SLEEVE-DRIVE

PROTECTOR

INDUSTRIAL

AUTOMOTIVE

MOTORCYCLE

CONSTRUCTION

SPARE PART

3285Z Set in PE-foam tray
Steckschlüsselsatz in Weichschaumeinlage
Set disposé dans boîte de rangement en mousse souple



3285ZA Set in PE-foam tray
Steckschlüsselsatz in Weichschaumeinlage
Set disposé dans boîte de rangement en mousse souple



3285ZE Socket Sets
Steckschlüssel Sätze
Jeu de clés à douilles



RSAL200-1/4x12/-3/8x8  Magnetic Rail with retaining clips
RSAL300-3/8x12/-1/2x10 Magnetschiene mit Halteklammern
Rail à aimant avec clips de maintien











RSAL-200/-300/-400 Magnetic Rails and retaining Clips, bulk
CLIP.P/5-1/4/-3/8/-1/2 Magnetschiene und Halteklammern, lose
Rail à aimant avec clips de maintien, en vrac





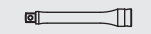

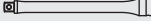
3285Z 26 Pieces Set/ =2,100g

PLASTIC TRAY:W390xT180xH25

Sockets	Accessories
 3400MZ 6-pt. Sockets 5.5, 6, 7, 8, 10, 12, 13, 14, 17, 19, 21, 22	 3725Z
 3300MZ 6-pt. Deep Sockets 8, 10, 12, 14	 3756Z
 3300CZ Spark Plug Sockets 14, 16, 20.8	 3771Z
	 3768Z-250
	 3760Z-75
	 3760Z-125
	 3760Z-250



3285ZA 15 Pieces Set/ =750g





PLASTIC TRAY:W300xT90xH25





Sockets	Accessories
 3400MZ 6-pt. Sockets 5.5, 6, 7, 8, 10, 12, 13, 14, 17, 19, 21, 22	 3725Z
	 3756Z
	 3771Z

3285ZE 9 Pieces Set/ =600g

Rail 200mm/PLASTIC BAG



Sockets	Accessories
 3400MZ 6-pt. Sockets 8, 10, 12, 13, 14, 17, 19	 3725Z
	 3756Z

RSAL200		RAIL (mm)	CLIP (pcs.)	 (g)	 (pce.)
1/4x12	 1/4"	200	12	125	1
3/8x8	 3/8"	200	8	130	1







RSAL300		RAIL (mm)	CLIP (pcs.)	 (g)	 (pce.)
3/8x12	 3/8"	300	12	180	1
1/2x10	 1/2"	300	10	190	1



RAIL

	RAIL (mm)	 (g)	 (pce.)
RSAL200	200	110	1
RSAL300	300	145	1
 RSAL400	400	210	1

CLIP

CLIP.P/5		 (g)	 (pce.)
1/4	 1/4"	10	5
3/8	 3/8"	13	5
1/2	 1/2"	20	5

1/2"

Z-series
Z-serie
Series-Z

4400MZ (mm)	D ₁ (mm)	D ₂ (mm)	ℓ (mm)	L (mm)	(g)	(pcs.)
8	12.6	20.6	4.5	26	30	10
10	15	20.6	4.5	26	31	10
12	17.5	20.6	5.5	27	32	10
13	18.7	21.5	6.5	28	40	10
14	19.8	21.5	6.5	28	40	10
16	22.3	21.5	7.5	28	43	10
17	23.6	22.5	7.5	29	49	10
18	24.8	23.7	7.5	29	56	10
19	26	24.4	9.5	29	62	10
21	28.4	26.3	10.5	29	76	10
22	29.6	27.5	11	29	83	10
24	32	29.2	12	29	96	5
27	35.7	32.2	13.5	30	124	5
30	39.3	35.2	14.5	31	156	5
32	41.7	36.8	15.5	32	178	5

4400MZ  6-point Sockets
6-kant Steckschlüssel
Douilles 6-pans

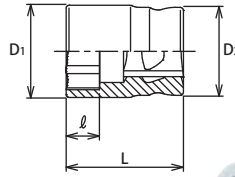

RS4400MZ/10	10 Pieces Set/Rail 300mm	(g)
10, 12, 13, 14, 17, 19, 21, 22, 24, 27		830

RS4400MZ/10   Socket Set on magnetic Rail
Steckschlüsselsatz auf Magnetschiene
Jeu de douilles sur rail à aimant



4725Z Reversible Ratchet
Knarre, verstellbar
Cliquet, réversible

36



	D (mm)	T (mm)	H (mm)	L (mm)	(g)	(pce.)
4725Z	36.5	32.8	18.2	253	590	1

* Renewal Kits → **4725RK** → P299

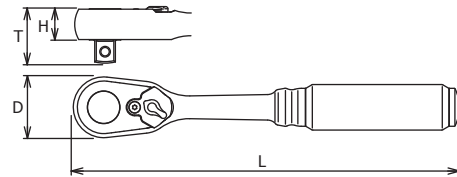

4768Z-430 Hinge Handle
Gelenkgriff
Poignée articulée



	D (mm)	L (mm)	(g)	(pce.)
4768Z-430	28	430	720	1

* Renewal Kits → **4768ZRK** → P300

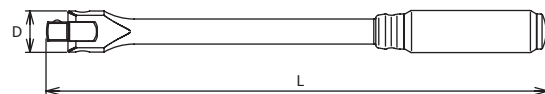

Z-SERIES
HAND
TITANIUM
ACCESSORIES
SCREWDRIVERS
IMPACT
SLEEVE-DRIVE
PROTECTOR
INDUSTRIAL
AUTOMOTIVE
MOTORCYCLE
CONSTRUCTION
SPARE PART

Z-SERIES
HAND
TITANIUM
SCREWDRIVERS
ACCESSORIES
IMPACT
SLEEVE-DRIVE
PROTECTOR
INDUSTRIAL
AUTOMOTIVE
MOTORCYCLE
CONSTRUCTION
SPARE PART

4760Z-125/-250

Extension Bars
Verlängerungen
Rallonges

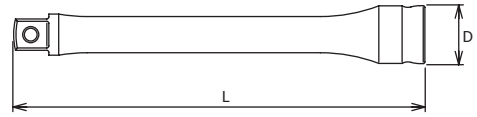

4760Z	D (mm)	L (mm)	(g)	(pcs.)
125	22.5	125	180	5
250	22.5	250	340	5

4771Z

Universal Joint
Gelenk-Einsatz
Joint articlé

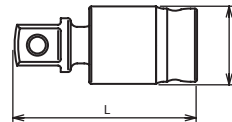

4771Z	D (mm)	L (mm)	(g)	(pcs.)
4771Z	23.7	55.8	100	10

4756Z

Quick Spinner
Rändel-Drehscheibe
Lanceur

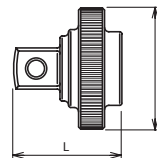

4756Z	D (mm)	L (mm)	(g)	(pcs.)
4756Z	36.3	33.5	84	10

4285Z

Set in Foam tray
Steckschlüsselsatz in Weichschaumeinlage
Set disposé dans boîte de rangement en mousse souple



4285Z		21 Pieces Set/△=4,800g
METAL CASE:W445×T190×H50		
Sockets	Accessories	
4400MZ 6-pt. Sockets 8, 10, 12, 13, 14, 16, 17, 18, 19, 21, 22, 24, 27, 30, 32	4725Z	
	4756Z	
	4771Z	
	4768Z-430	
	4760Z-125	
	4760Z-250	

4285ZE

Socket Sets
Steckschlüssel Sätze
Jeu de clés à douilles



4285ZE		11 Pieces Set/△=1,380g
Rail 300mm/PLASTIC BAG		
Sockets	Accessories	
4400MZ 6-pt. Sockets 10, 12, 13, 14, 17, 19, 21, 22, 24	4725Z	
	4756Z	

HAND

SOCKETS
STECKSCHLÜSSEL
DOUILLES

1/4"

3/8"

1/2"

3/4"

1"



Z-SERIES
HAND
TITANIUM
SCREWDRIVERS ACCESSORIES
IMPACT
SLEEVE-DRIVE
PROTECTOR
INDUSTRIAL
AUTOMOTIVE
MOTORCYCLE
CONSTRUCTION
SPARE PART

2400M / 2400A

6-point Sockets
6-kant Steckschlüssel
Douilles 6-pans

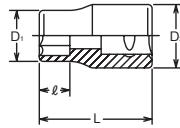

2400M 2405M (mm)	D ₁ (mm)	D ₂ (mm)	ℓ (mm)	L (mm)	(g)	(pcs.)
3	5.5	11.2	2.6	22	7	10
3.5	6.1	11.2	3	22	7	10
4	6.7	11.2	3.5	22	8	10
4.5	7.3	11.2	4	22	8	10
5	8	11.2	5	22	8	10
5.5	8.5	11.2	5.5	22	9	10
6	9.2	11.2	5.5	22	9	10
7	10.3	11.2	6	22	9	10
8	11.2	11.7	6.9	22	11	10
9	13	12	7.3	22	12	10
10	14.3	12.9	7.7	22	15	10
11	15.5	14.3	9.3	22	18	10
12	16.8	15.5	9.3	22	23	10
13	18	16.4	9.8	22	23	10
14	19.3	17.9	11	24	30	10

2405M / 2405A

12-point Sockets
12-kant Steckschlüssel
Douilles 12-pans

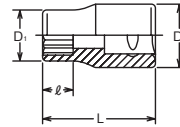

2400A 2405A (inch)	D ₁ (mm)	D ₂ (mm)	ℓ (mm)	L (mm)	(g)	(pcs.)
1/8	5.7	11.2	2.7	22	7	10
5/32	6.7	11.2	3.5	22	8	10
3/16	7.8	11.2	5	22	8	10
7/32	8.5	11.2	5.5	22	9	10
1/4	9.6	11.2	5.8	22	9	10
9/32	10.3	11.2	6	22	9	10
5/16	11.2	11.7	6.9	22	11	10
11/32	12.5	11.7	7.3	22	12	10
3/8	13.7	12.5	7.7	22	15	10
7/16	15.5	14.3	9.3	22	18	10
1/2	18	16.4	9.8	22	23	10
9/16	19.3	17.9	11	24	30	10

RS2400M/11 RS2405M/11

Socket Set on Rail
Steckschlüsselsatz auf Schiene
Jeu de douilles sur rail



RS2400M/11	11 Pieces Set/Rail 200mm	(g)
4, 5, 6, 7, 8, 9, 10, 11, 12, 13, 14		222

RS2405M/11	11 Pieces Set/Rail 200mm	(g)
4, 5, 6, 7, 8, 9, 10, 11, 12, 13, 14		222

RS2400A/9 RS2405A/9

Socket Set on Rail
Steckschlüsselsatz auf Schiene
Jeu de douilles sur rail



RS2400A/9	9 Pieces Set/Rail 150mm	(g)
3/16, 7/32, 1/4, 9/32, 5/16, 11/32, 3/8, 7/16, 1/2		162

RS2405A/9	9 Pieces Set/Rail 150mm	(g)
3/16, 7/32, 1/4, 9/32, 5/16, 11/32, 3/8, 7/16, 1/2		162

2400W-BA

6-point Sockets
6-kant Steckschlüssel
Douilles 6-pans

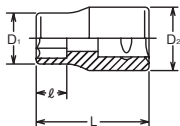

2400W (BA)	D ₁ (mm)	D ₂ (mm)	ℓ (mm)	L (mm)	(g)	(pcs.)
8	6.1	11.2	3	22	7	10
7	7.3	11.2	4	22	8	10
6	8	11.2	5	22	8	10
5	8.5	11.2	5.5	22	9	10
4	9.6	11.2	5.8	22	9	10
3	10.3	11.2	6	22	9	10
2	11.2	11.7	6.9	22	11	10
1	13	12	7.3	22	12	10
0	14.9	13.6	8	22	16	10

RS2400W/9-BA

Socket Set on Rail
Steckschlüsselsatz auf Schiene
Jeu de douilles sur rail



RS2400W/9-BA	9 Pieces Set/Rail 150mm	(g)
8, 7, 6, 5, 4, 3, 2, 1, 0		120

1/4"

Hand Sockets
Hand Steckschlüssel
Douilles à main

AS2405A (inch)	D ₁ (mm)	D ₂ (mm)	ℓ (mm)	L (mm)	(g)	(pcs.)
3/16	7.7	10.9	4.5	22	8	10
7/32	8.5	10.9	4.9	22	8	10
1/4	9.4	10.9	5.3	22	8	10
9/32	10.2	10.9	5.5	22	8	10
5/16	11.3	11.7	6.4	22	10	10
11/32	12.5	12	6.8	22	10	10
3/8	13.7	12.9	6.8	22	13	10
7/16	15.6	14.3	8.8	22	17	10
1/2	17.2	16.4	8.9	22	20	10
9/16	18.8	17.9	9.1	24	27	10

Aerospace Standard SAE AS954

RSAS2405A/10	10 Pieces Set/Rail 150mm	(g)
3/16, 7/32, 1/4, 9/32, 5/16, 11/32, 3/8, 7/16, 1/2, 9/16		160

2410M (mm)	D ₁ (mm)	D ₂ (mm)	ℓ (mm)	L (mm)	(g)	(pcs.)
4	6.7	11.2	3.5	22	8	10
4.5	7.3	11.2	4	22	8	10
5	8	11.2	5	22	8	10
5.5	8.5	11.2	5.5	22	9	10
6	9.2	11.2	5.5	22	9	10
7	10.3	11.2	6	22	9	10
8	11.2	11.7	6.9	22	11	10
9	13	12	7.3	22	12	10
10	14.3	12.9	7.7	22	15	10
11	15.5	14.3	9.3	22	18	10
12	16.8	15.5	9.3	22	23	10
13	18	16.4	9.8	22	23	10
14	19.3	17.9	11	24	30	10

RS2410M/11	11 Pieces Set/Rail 200mm	(g)
4, 5, 6, 7, 8, 9, 10, 11, 12, 13, 14		222

2415M (mm)	D ₁ (mm)	D ₂ (mm)	ℓ (mm)	L (mm)	(g)	(pcs.)
New 5.5	10.3	11.2	5.4	22	10	10
6	11	11.7	5.4	22	13	10
New 7	12.5	11.7	6.1	22	13	10
8	14.3	12.9	6.8	22	17	10
10	17.4	16	8.2	22	27	10

2415A (inch)	D ₁ (mm)	D ₂ (mm)	ℓ (mm)	L (mm)	(g)	(pcs.)
1/4	11	11.7	5.4	22	14	10
5/16	14.3	12.9	6.8	22	17	10
3/8	17.4	16	8.2	22	26	10

2425 (E)	D ₁ (mm)	D ₂ (mm)	ℓ (mm)	L (mm)	(g)	(pcs.)
E 4	5.4	11.2	4.6	22	7	10
E 5	6.7	11.2	5.2	22	8	10
E 6	7.7	11.2	5.4	22	8	10
E 7	8.3	11.2	6.6	22	9	10
E 8	9.6	11.2	7	22	9	10
E10	11.3	12	8.2	22	10	10
New E11	12.9	12	8.7	22	13	10
New E12	14.3	12.9	9.3	23	17	10

TORX®
(E)

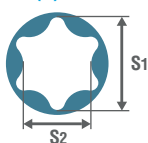

E	E4	E5	E6	E7	E8	E10	E11	E12	E14	E16	E18	E20	E22	E24	E26	E28
S ₁ (ref. mm)	3.7	4.6	5.6	6.1	7.4	9.3	9.9	11.0	12.8	14.6	16.5	18.3	20.1	22.0	23.7	25.5
S ₂ (ref. mm)	2.7	3.3	4.0	4.3	5.3	6.8	7.1	7.9	9.2	10.5	11.9	13.2	14.8	15.7	17.5	18.3

RS2425/6	6 Pieces Set/Rail 150mm	(g)
E4, E5, E6, E7, E8, E10		90

AS2405A 12-point Sockets, AS954
12-kant Steckschlüssel, AS954
Douilles 12-pans, AS954

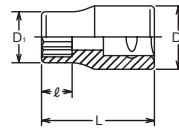

RSAS2405A/10 Socket Set on Rail
Steckschlüsselsatz auf Schiene
Jeu de douilles sur rail



2410M Surface Drive Sockets
Surface Drive Steckschlüssel
Douilles, Surface Drive

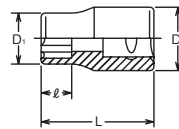

RS2410M/11 Socket Set on Rail
Steckschlüsselsatz auf Schiene
Jeu de douilles sur rail



2415M / 2415A Double 4-point Sockets
Doppelvierkant Steckschlüssel
Douilles mâles 4-pans doubles

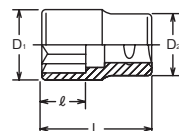

2425 TORX® Sockets
TORX® Steckschlüssel
Douilles TORX®

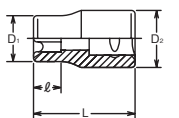

RS2425/6 Socket Set on Rail
Steckschlüsselsatz auf Schiene
Jeu de douilles sur rail



Hand Sockets Hand Steckschlüssel 1/4" Douilles à main

Z-SERIES
HAND
TITANIUM
SCREWDRIVERS
ACCESSORIES
IMPACT
SLEEVE-DRIVE
PROTECTOR
INDUSTRIAL
AUTOMOTIVE
MOTORCYCLE
CONSTRUCTION
SPARE PART

2450MS Nut Grip Sockets **Nut Grip®** Steckschlüssel mit 2-facher Kugelhalterung Douilles à billes de retenue

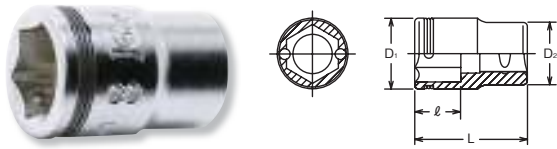

2450MS (mm)	D ₁ (mm)	D ₂ (mm)	ℓ (mm)	L (mm)	(g)	(pcs.)
7	11.3	11.2	4	18	8	10
8	12.3	11.2	5	18	9	10
10	14.3	12.9	6	19	13	10
12	17.4	16	7	20	22	10
13	18	16.4	8	20	22	10
14	19.9	18	8.5	22	31	10

RS2450MS/6 Socket Set on Rail Steckschlüsselsatz auf Schiene Jeu de douilles sur rail



RS2450MS/6	6 Pieces Set/Rail 150mm	(g)
7, 8, 10, 12, 13, 14		120

2300X 6-point Sockets, Semi-Deep 6-kant Steckschlüssel, mittel-lang Douilles, semi-profondes 6-pans

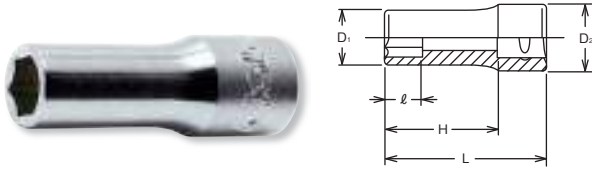

2300X (mm)	D ₁ (mm)	D ₂ (mm)	ℓ (mm)	H (mm)	L (mm)	(g)	(pcs.)
4	6.7	11.2	4	22	32	10	10
5	8	11.2	5.5	22	32	11	10
6	9.2	11.2	7	22	32	12	10
7	10.5	11.2	8	22	32	13	10
8	11.8	11.2	9	22	32	16	10
9	13	12	10	22	32	18	10
10	14.3	12.9	11	21	32	23	10
11	15.5	14.3	12	21	32	27	10
12	16.8	15.5	13	21	32	29	10
13	18	16.4	14	21	32	32	10
14	19.3	17.9	16	20	32	37	10

RS2300X/11 Socket Set on Rail Steckschlüsselsatz auf Schiene Jeu de douilles sur rail



RS2300X/11	11 Pieces Set/Rail 200mm	(g)
4, 5, 6, 7, 8, 9, 10, 11, 12, 13, 14		300

2350X Nut Grip Socket, Semi-Deep **Nut Grip®** Steckschlüssel mit 2-facher Kugelhalterung, mittel-lang Douilles à billes de retenue, semi-profondes

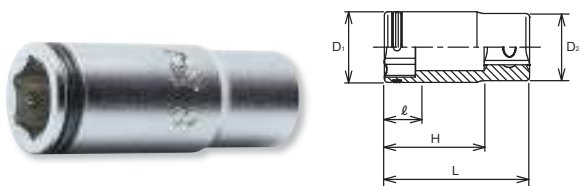

2350X (mm)	D ₁ (mm)	D ₂ (mm)	ℓ (mm)	H (mm)	L (mm)	(g)	(pcs.)
8	12.3	11.2	5	22	32	17	10
10	14.2	12.9	6	22	32	22	10
12	17.3	16	7	22	32	34	10
14	20	18	8.5	22	32	43	10

RS2350X/4 Socket Set on Rail Steckschlüsselsatz auf Schiene Jeu de douilles sur rail



RS2350X/4	4 Pieces Set/Rail 150mm	(g)
8, 10, 12, 14		140

2300M 2305M (mm)	D ₁ (mm)	D ₂ (mm)	ℓ (mm)	H (mm)	L (mm)	(g)	(pcs.)
3	5.5	11.2	3	40	50	15	10
4	6.7	11.2	4	40	50	15	10
4.5	7.3	11.2	4.5	40	50	15	10
5	8	11.2	5.5	40	50	17	10
5.5	8.5	11.2	6	40	50	17	10
6	9.2	11.2	7	40	50	20	10
7	10.5	11.2	8	40	50	25	10
8	11.8	11.2	9	40	50	25	10
9	13	12	10	40	50	30	10
10	14.3	12.9	11	39	50	34	10
11	15.5	14.3	12	39	50	43	10
12	16.8	15.5	13	39	50	50	10
13	18	16.4	14	39	50	52	10
14	19.3	17.9	16	38	50	57	10

2300A 2305A (inch)	D ₁ (mm)	D ₂ (mm)	ℓ (mm)	H (mm)	L (mm)	(g)	(pcs.)
1/8	5.7	11.2	3.5	40	50	15	10
5/32	6.7	11.2	4	40	50	15	10
3/16	7.8	11.2	5.5	40	50	17	10
7/32	8.5	11.2	6	40	50	17	10
1/4	9.8	11.2	7	40	50	25	10
9/32	10.5	11.2	8	40	50	25	10
5/16	11.8	11.2	9	40	50	25	10
11/32	12.5	11.7	10	40	50	30	10
3/8	13.7	12.5	11	40	50	34	10
7/16	15.5	14.3	12	39	50	43	10
1/2	18	16.4	14	39	50	52	10
9/16	19.3	17.9	16	38	50	57	10

RS2300M/11	11 Pieces Set/Rail 200mm	(g)
4, 5, 6, 7, 8, 9, 10, 11, 12, 13, 14		437

RS2305M/11	11 Pieces Set/Rail 200mm	(g)
4, 5, 6, 7, 8, 9, 10, 11, 12, 13, 14		437

RS2300A/9	9 Pieces Set/Rail 150mm	(g)
3/16, 7/32, 1/4, 9/32, 5/16, 11/32, 3/8, 7/16, 1/2		296

RS2305A/9	9 Pieces Set/Rail 150mm	(g)
3/16, 7/32, 1/4, 9/32, 5/16, 11/32, 3/8, 7/16, 1/2		296

2300W (BA)	D ₁ (mm)	D ₂ (mm)	ℓ (mm)	H (mm)	L (mm)	(g)	(pcs.)
4	9.8	11.2	7	40	50	22	10
3	10.5	11.2	8	40	50	25	10
2	11.8	11.2	9	40	50	25	10
1	13	12	10	40	50	30	10
0	14.9	13.6	12	39	50	38	10

BA



BA	8BA	7BA	6BA	5BA	4BA	3BA	2BA	1BA	0BA
Across Flat (ref. mm)	3.9	4.4	4.9	5.6	6.3	7.2	8.2	9.3	10.5
(ref. inch)	0.2	0.2	0.2	0.2	0.2	0.3	0.3	0.4	0.4

2300M / 2300A

6-point Deep Sockets
6-kant-Steckschlüssel, lang
Douilles longues 6-pans

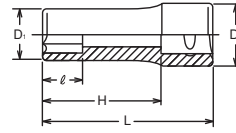

2305M / 2305A

12-point Deep Sockets
12-kant Steckschlüssel, lang
Douilles longues, 12-pans

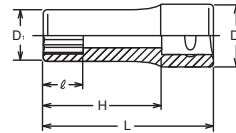

RS2300M/11

Socket Set on Rail
Steckschlüsselsatz auf Schiene
Jeu de douilles sur rail

RS2305M/11



RS2300A/9

Socket Set on Rail
Steckschlüsselsatz auf Schiene
Jeu de douilles sur rail

RS2305A/9



2300W-BA

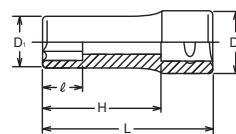

6-point Deep Sockets
6-kant-Steckschlüssel, lang
Douilles longues 6-pans



Hand Sockets
Hand Steckschlüssel
Douilles à main

1/4"

Z-SERIES
HAND
TITANIUM
SCREWDRIVERS ACCESSORIES
IMPACT
SLEEVE-DRIVE
PROTECTOR
INDUSTRIAL
AUTOMOTIVE
MOTORCYCLE
CONSTRUCTION
SPARE PART

AS2305A  12-point Deep Sockets, AS954
12-kant Steckschlüssel, lang, AS954
Douilles longues 12-pans, AS954 

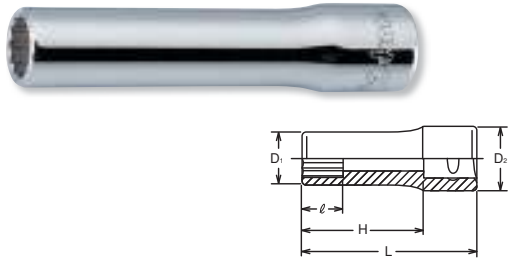

AS2305A (inch)	D ₁ (mm)	D ₂ (mm)	ℓ (mm)	H (mm)	L (mm)	(g)	(pcs.)
3/16	7.7	10.9	4.5	40	50	17	10
7/32	8.5	10.9	4.9	40	50	17	10
1/4	9.4	10.9	5.3	40	50	19	10
9/32	10.2	10.9	5.5	40	50	18	10
5/16	11.3	11.7	6.4	40	50	23	10
11/32	12.5	12	6.8	40	50	24	10
3/8	13.7	12.8	6.8	39	50	31	10
7/16	15.6	14.2	8.8	39	50	38	10
1/2	17.2	16.2	8.9	39	50	42	10
9/16	18.8	17.1	9.1	38	50	47	10

Aerospace Standard SAE AS954

RSAS2305A/10  Socket Set on Rail
Steckschlüsselsatz auf Schiene
Jeu de douilles sur rail 



RSAS2305A/10	10 Pieces set/Rail 150mm	(g)
3/16, 7/32, 1/4, 9/32, 5/16, 11/32, 3/8, 7/16, 1/2, 9/16		307

2310M  Surface Drive Deep Sockets
Surface Drive Steckschlüssel, lang
Douilles longues, Surface Drive

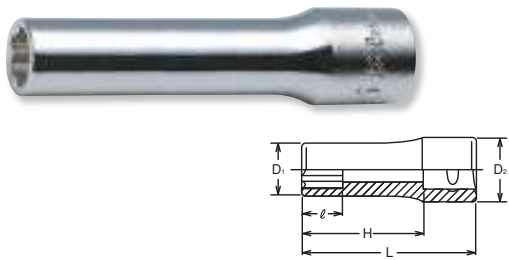

2310M (mm)	D ₁ (mm)	D ₂ (mm)	ℓ (mm)	H (mm)	L (mm)	(g)	(pcs.)
3	5.5	11.2	3	40	50	15	10
4	6.7	11.2	4	40	50	15	10
4.5	7.3	11.2	4.5	40	50	15	10
5	8	11.2	5.5	40	50	17	10
5.5	8.5	11.2	6	40	50	17	10
6	9.2	11.2	7	40	50	20	10
7	10.5	11.2	8	40	50	25	10
8	11.8	11.2	9	40	50	25	10
9	13	12	10	40	50	30	10
10	14.3	12.9	11	39	50	34	10
11	15.5	14.3	12	39	50	43	10
12	16.8	15.5	13	39	50	50	10
13	18	16.4	14	39	50	52	10
14	19.3	17.9	16	38	50	57	10

RS2310M/11  Socket Set on Rail
Steckschlüsselsatz auf Schiene
Jeu de douilles sur rail



RS2310M/11	11 Pieces set/Rail 200mm	(g)
4, 5, 6, 7, 8, 9, 10, 11, 12, 13, 14		437

2325  TORX® Deep Sockets
TORX® Steckschlüssel, lang
Douilles longues TORX®

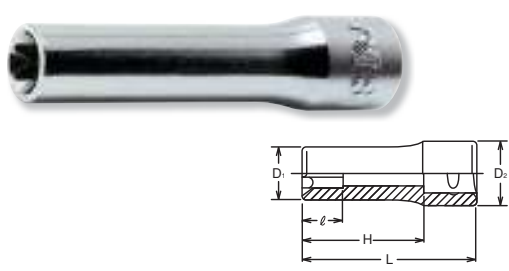

2325 (E)	D ₁ (mm)	D ₂ (mm)	ℓ (mm)	H (mm)	L (mm)	(g)	(pcs.)
E 4	5.4	12	4.6	40	50	17	10
E 5	6.8	12	5.2	40	50	20	10
E 6	8	12	5.4	40	50	20	10
E 7	8.3	12	6.6	40	50	22	10
E 8	9.8	12	7	40	50	25	10
E10	11.6	12	8.2	40	50	29	10

2350M (mm)	D ₁ (mm)	D ₂ (mm)	ℓ (mm)	H (mm)	L (mm)	(g)	(pcs.)
8	12.3	11.2	5	40	50	30	10
10	14.2	12.9	6	39	50	35	10
12	17.3	16	7	39	50	55	10
14	19.9	18	8.5	38	50	70	10



NUT GRIP®

Twin balls at the 6-point opening hold bolt/nut tightly for safe and reliable work.

Die zwei Kugeln in der 6-kant Öffnung unserer NUT GRIP Steckschlüssel halten die Schraube sicher im Steckschlüssel. Dies erlaubt ein Arbeiten auch an schwer zugänglichen Stellen.

Les 2 billes dans l'ouverture du 6-pan de la douille retiennent l'écrou de manière sûre et efficace.

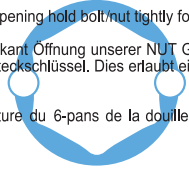

RS2350M/4	4 Pieces Set/Rail 150mm	(g)
New	8, 10, 12, 14	220

2440M 2445M (mm)	D ₁ (mm)	D ₂ (mm)	ℓ (mm)	L (mm)	(g)	(pcs.)
4	6.7	13	4.8	31.5	17	10
5	8	13	5.3	32	17	10
6	9.2	13	6.1	33	18	10
7	10.5	13	6.5	33	19	10
8	11.7	13	7	34	19	10
9	13	13	7	34	20	10
10	14.2	13	8.3	35	20	10
11	15.5	13	9.5	36	21	10
12	16.7	13	10	37	21	10
13	18	13	10.5	37	26	10
14	19.2	13	10.5	37	28	10

2440A (inch)	D ₁ (mm)	D ₂ (mm)	ℓ (mm)	L (mm)	(g)	(pcs.)
1/4	9.8	13	6.5	33	18	10
5/16	11.7	13	7	34	19	10
3/8	13.7	13	8.3	35	20	10
7/16	15.5	13	9.5	36	21	10
1/2	18	13	10.5	37	26	10
9/16	19.2	13	10.5	37	28	10

2445A (inch)	D ₁ (mm)	D ₂ (mm)	ℓ (mm)	L (mm)	(g)	(pcs.)
3/16	8	13	5.3	32	18	10
1/4	9.8	13	6.5	33	18	10
9/32	10.5	13	6.5	33	19	10
5/16	11.7	13	7	34	19	10
11/32	13	13	7	34	20	10
3/8	13.7	13	8.3	35	20	10
7/16	15.5	13	9.5	36	21	10
1/2	18	13	10.5	37	26	10
9/16	19.2	13	10.5	37	28	10

RS2445A/9	9 Pieces set/Rail 150mm	(g)
3/16, 1/4, 9/32, 5/16, 11/32, 3/8, 7/16, 1/2, 9/16		220

AS2445A (inch)	D ₁ (mm)	D ₂ (mm)	ℓ (mm)	L (mm)	(g)	(pcs.)
1/4	9.6	12.9	5.7	31.8	18	10
5/16	11.7	12.9	7	34.6	21	10
3/8	13.5	12.9	8.3	35.1	21	10
7/16	15.5	12.9	9.5	39.1	25	10
1/2	17.2	12.9	10.5	40.1	27	10

2350M Nut Grip Deep Sockets **Nut Grip®**
Steckschlüssel mit 2-facher Kugelhalterung, lang
Douilles longues à billes de retenue

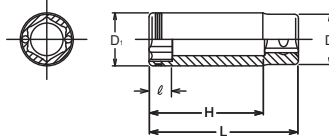

RS2350M/4 Socket Set on Rail
Steckschlüsselsatz auf Schiene
Jeu de douilles sur rail



2440M / 2440A 6-point Universal Sockets
6-kant Gelenk-Einsätze
Douilles universelles, 6-pan

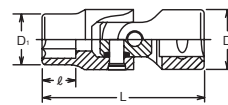

2445M / 2445A 12-point Universal Sockets
12-kant Gelenk-Einsätze
Douilles universelles, 12-pan

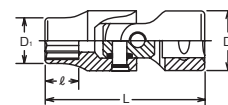

RS2445A/9 Socket Set on Rail
Steckschlüsselsatz auf Schiene
Jeu de douilles sur rail



AS2445A 12-point Universal Sockets
12-kant Gelenk-Einsätze
Douilles universelles, 12-pan

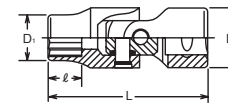

Hand Sockets Hand Steckschlüssel 1/4"

2440T TORX® Universal Sockets TORX® Gelenk-Einsätze Douilles universelles TORX®

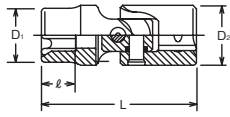

2440T (E)	D ₁ (mm)	D ₂ (mm)	l (mm)	L (mm)	(g)	(pcs.)
E 6	8	13	5.4	31.9	20	10
E 8	9.8	13	7	33.1	20	10
E10	11.7	13	8.2	33.6	21	10
E12	14.2	13	9.3	35.1	24	10

2441M Nut Grip Universal Sockets **Nut Grip**® Gelenk-Einsätze mit zweifacher Kugelhalterung Douilles universelles à billes de retenue

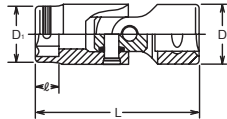

2441M (mm)	D ₁ (mm)	D ₂ (mm)	l (mm)	L (mm)	(g)	(pcs.)
7	11.3	13	4	33	19	10
8	12.3	13	5	32	19	10
10	14.5	13	6	32.5	21	10
12	16.8	13	7	34	21	10
13	18	13	8	35	21	10
14	20	13	8.5	37	28	10

2430M Universal Hex Sockets Gelenk-Einsätze für Schrauben mit Innensechskant Douilles universelles, 6-pans mâles

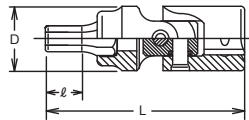

2430M (mm)	D (mm)	l (mm)	L (mm)	(g)	(pcs.)
3	13	5.5	40	18	10
4	13	5.5	40	18	10
5	13	6.5	40	20	10
6	13	7.5	40	21	10

2430T TORX® Universal Sockets TORX® Gelenk-Einsätze Douilles universelles TORX®

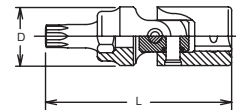

2430T (T)	D (mm)	L (mm)	(g)	(pcs.)
T 8	13	42	22	10
T 9	13	42	22	10
T10	13	42	22	10
T15	13	42	22	10
T20	13	42	22	10
T25	13	42	22	10
T27	13	42	22	10
T30	13	42	22	10

2000-28 (PH) Phillips Bit Sockets Steckschlüssel für Kreuzschlitzschrauben, Phillips Douilles tournevis pour vis à empreinte Phillips

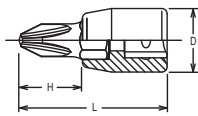

2000-28 (PH)	D (mm)	H (mm)	L (mm)	(g)	(pcs.)
1	11.9	12	28	10	10
2	11.9	12	28	11	10
3	11.9	12	28	12	10
4	13.1	11	28	14	10

2000-28 (PZ) PZ Bit Sockets Steckschlüssel für Kreuzschlitzschrauben, PZ Douilles tournevis pour vis à empreinte PZ

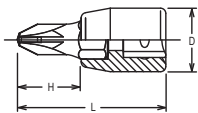

2000-28 (PZ)	D (mm)	H (mm)	L (mm)	(g)	(pcs.)
PZ1	11.9	12	28	10	10
PZ2	11.9	12	28	11	10
PZ3	11.9	12	28	12	10

2005-25 Bit Sockets for Slotted Head Steckschlüssel für Schlitzschrauben Douilles tournevis pour vis à fente

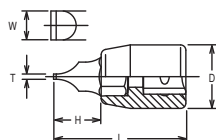

2005-25	T×W (mm)	D (mm)	H (mm)	L (mm)	(g)	(pcs.)
3	0.5× 3	11.9	9	25	9	10
4	0.8× 4	11.9	9	25	10	10
5	1.0× 5.5	11.9	9	25	10	10
6	1.2× 6.5	13.1	9	25	11	10
8	1.2× 8	13.1	9	25	12	10
9	1.6× 8	13.1	9	25	12	10
10	1.6×10	14.3	9	25	13	10

Z-SERIES
HAND
TITANIUM
SCREWDRIVERS
ACCESSORIES
IMPACT
SLEEVE-DRIVE
PROTECTOR
INDUSTRIAL
AUTOMOTIVE
MOTORCYCLE
CONSTRUCTION
SPARE PART

2010M-25 (mm)	D (mm)	H (mm)	L (mm)	(g)	(pcs.)
1.5	11.9	9	25	9	10
2	11.9	9	25	9	10
2.5	11.9	9	25	9	10
3	11.9	9	25	9	10
4	11.9	9	25	9	10
5	11.9	9	25	10	10
6	11.9	9	25	12	10
7	13.1	8	25	12	10
8	13.1	8	25	14	10
10	14.3	8	25	17	10
New 12	16.4	8	25	36	10

2010M-100 (mm)	D (mm)	H (mm)	L (mm)	(g)	(pcs.)
2	11.9	84	100	30	10
2.5	11.9	84	100	30	10
3	11.9	84	100	30	10
4	11.9	84	100	30	10
5	13.1	83	100	30	10
6	13.1	83	100	35	10
7	13.1	83	100	35	10
8	13.1	83	100	38	10
10	14.3	83	100	45	10
New 12	16.4	83	100	107	10

2010A-25 (inch)	D (mm)	H (mm)	L (mm)	(g)	(pcs.)
1/8	11.9	9	25	9	10
5/32	11.9	9	25	9	10
3/16	11.9	9	25	10	10
7/32	11.9	9	25	11	10
1/4	11.9	9	25	12	10
9/32	13.1	8	25	12	10
5/16	13.1	8	25	14	10
3/8	14.3	8	25	17	10

RS2010M/7-L25	7 Pieces set/Rail 150mm	(g)
3, 4, 5, 6, 7, 8, 10		115

RS2010A/8-L25	8 Pieces set/Rail 150mm	(g)
1/8, 5/32, 3/16, 7/32, 1/4, 9/32, 5/16, 3/8		130

2011M-50 (mm)	D (mm)	H (mm)	L (mm)	(g)	(pcs.)
3	11.9	34	50	16	10
4	11.9	34	50	17	10
5	11.9	34	50	18	10
6	11.9	34	50	18	10

⚠ Ball point bit sockets have less strength due to the special design. Make sure to use them correctly.



2020-28 (XZN)	D (mm)	H (mm)	L (mm)	(g)	(pcs.)
M4	11.9	12	28	12	10
M5	11.9	12	28	12	10
M6	11.9	12	28	13	10
M8	13.1	11	28	14	10

2020-50 (XZN)	D (mm)	H (mm)	L (mm)	(g)	(pcs.)
M4	11.9	34	50	20	10
M5	11.9	34	50	20	10
M6	11.9	34	50	22	10
M8	13.1	33	50	24	10

2010M-25/-100 2010A-25

● Inhex Bit Sockets
Steckschlüssel für Innensechskant-Schrauben
Douilles tournevis pour vis 6-pans creux

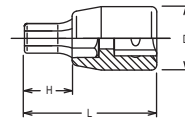

RS2010M/7-L25 RS2010A /8-L25

● Socket Set on Rail
Steckschlüsselsatz auf Schiene
Jeu de douilles sur rail



2011M-50

● Ballpoint Inhex Sockets
Steckschlüssel mit Kugelkopf, für Innensechskant-Schrauben ⚠
Douilles tournevis avec tête sphérique pour vis 6-pans creux

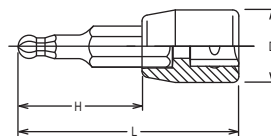

2020-28/-50

● XZN Bit Sockets
Steckschlüssel für XZN Schrauben
Douilles tournevis pour empreinte XZN

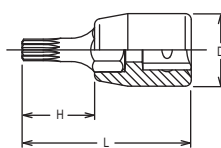

2025-28/-80 (T)

 TORX® Bit Sockets
TORX® Bit-Steckschlüssel
Douilles tournevis, TORX®

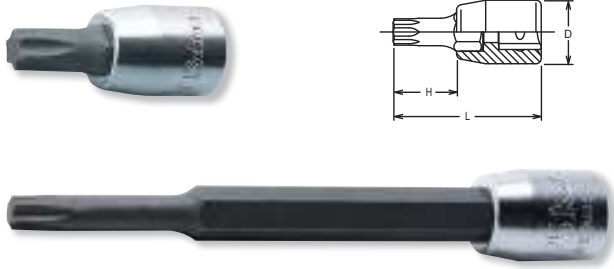

2025-28 (T)	D (mm)	H (mm)	L (mm)	(g)	(pcs.)
T 8	11.9	12	28	10	10
T 9	11.9	12	28	10	10
T10	11.9	12	28	10	10
T15	11.9	12	28	10	10
T20	11.9	12	28	11	10
T25	11.9	12	28	11	10
T27	11.9	12	28	12	10
T30	11.9	12	28	12	10
T40	11.9	12	28	13	10

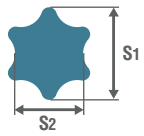

2025-80 (T)	D (mm)	H (mm)	L (mm)	(g)	(pcs.)
T10	11.9	64	80	40	10
T15	11.9	64	80	40	10
T20	11.9	64	80	42	10
T25	11.9	64	80	42	10
T27	11.9	64	80	45	10
T30	11.9	64	80	45	10
T40	11.9	64	80	50	10

TORX® (T)



T	T8	T9	T10	T15	T20	T25	T27	T30	T40	T45	T50	T55	T60	T70	T80	T90	T100
S ₁ (ref. mm)	2.3	2.5	2.7	3.3	3.9	4.5	5.0	5.6	6.7	7.9	8.9	11.3	13.3	15.6	17.6	20.0	22.2
S ₂ (ref. mm)	1.7	1.8	2.0	2.3	2.8	3.2	3.6	4.0	4.8	5.6	6.2	8.0	9.5	11.1	12.7	14.2	15.8

RS2025/7-L28

  Socket Set on Rail
Steckschlüsselsatz auf Schiene
Jeu de douilles sur rail



RS2025/7-L28	7 Pieces set/Rail 150mm	(g)
T10, T15, T20, T25, T27, T30, T40		119

2025-28 (TH)



 Tamper-Resistant TORX® Bit Sockets
Tamper-Resistant TORX® Bit-Steckschlüssel
Douilles tournevis, Tamper-Resistant TORX® 



2025-28 (TH)	D (mm)	H (mm)	L (mm)	(g)	(pcs.)
T10H	11.9	12	28	10	10
T15H	11.9	12	28	10	10
T20H	11.9	12	28	11	10
T25H	11.9	12	28	11	10
T27H	11.9	12	28	12	10
T30H	11.9	12	28	12	10
T40H	11.9	12	28	13	10

 Tamper Resistant TORX® Bit Sockets have less strength due to their special design. Make sure to use it correctly.

RS2025/7-L28 (TH)

  Socket Set on Rail
Steckschlüsselsatz auf Schiene
Jeu de douilles sur rail



RS2025/7-HOLE	7 Pieces set/Rail 150mm	(g)
T10H, T15H, T20H, T25H, T27H, T30H, T40H		119



2025-28 (IP)	D (mm)	H (mm)	L (mm)	(g)	(pcs.)
8IP	11.9	12	28	10	10
9IP	11.9	12	28	10	10
10IP	11.9	12	28	10	10
15IP	11.9	12	28	10	10
20IP	11.9	12	28	11	10
25IP	11.9	12	28	11	10
27IP	11.9	12	28	12	10
30IP	11.9	12	28	12	10
40IP	11.9	12	28	13	10

2025-28 (IP)



TORXPLUS® Bit Sockets
TORXPLUS® Bit-Steckschlüssel
Douilles tournevis, TORXPLUS®

TORXplus

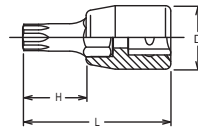

TORXPLUS® (IP)

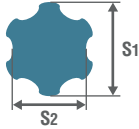

IP		8IP	9IP	10IP	15IP	20IP	25IP	27IP	30IP	40IP	45IP	50IP	55IP	60IP	70IP
S ₁	(ref. mm)	2.3	2.5	2.7	3.3	3.9	4.5	5.0	5.6	6.7	7.9	8.9	11.3	13.3	15.6
S ₂	(ref. mm)	1.7	1.8	2.0	2.3	2.8	3.2	3.6	4.0	4.8	5.6	6.2	8.0	9.5	11.1

RS2025/7-L28 (IP)	7 Pieces set/Rail 150mm	(g)
10IP, 15IP, 20IP, 25IP, 27IP, 30IP, 40IP		120

RS2025/7-L28 (IP)



Socket Set on Rail
Steckschlüsselsatz auf Schiene
Jeu de douilles sur rail



2025-28 (IPR)	D (mm)	H (mm)	L (mm)	(g)	(pcs.)
8IPR	11.9	12	28	10	10
9IPR	11.9	12	28	10	10
10IPR	11.9	12	28	10	10
15IPR	11.9	12	28	10	10
20IPR	11.9	12	28	11	10
25IPR	11.9	12	28	11	10
27IPR	11.9	12	28	12	10
30IPR	11.9	12	28	12	10
40IPR	13.1	12	28	13	10

2025-28 (IPR)



TORXPLUS® Bit Sockets, with hole
TORXPLUS® Bit-Steckschlüssel mit Stirnbohrung
douilles tournevis TORXPLUS® avec trou

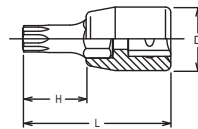

TORXPLUS® (IPR)

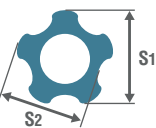

IPR		8IPR	9IPR	10IPR	15IPR	20IPR	25IPR	27IPR	30IPR	40IPR	45IPR	50IPR	55IPR
S ₁	(ref. mm)	2.2	2.4	2.6	3.1	3.6	4.1	4.7	5.2	6.3	7.4	8.4	10.6
S ₂	(ref. mm)	2.0	2.2	2.4	2.8	3.3	3.8	4.3	4.8	5.7	6.7	7.6	9.7

RS2025/7-L28 (IPR)	7 Pieces set/Rail 150mm	(g)
10IPR, 15IPR, 20IPR, 25IPR, 27IPR, 30IPR, 40IPR		120

RS2025/7-L28 (IPR)



Socket Set on Rail
Steckschlüsselsatz auf Schiene
Jeu de douilles sur rail



	D ₁ (mm)	D ₂ (mm)	L (mm)	(g)	(pcs.)
2137	12	12	22.5	13	10

For DIN3126 C6.3 Bits
Für DIN3126 C6.3 Bits
Pour DIN3126 C6.3 Embouts

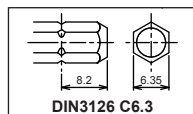

2137



Bit Holder
Klingenhalter
Porte-embouts

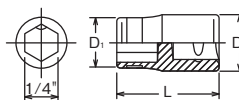

	D ₁ (mm)	D ₂ (mm)	L (mm)	(g)	(pcs.)
2138	16	16	26	32	10

For DIN3126 C8 Bits
Für DIN3126 C8 Bits
Pour DIN3126 C8 Embouts

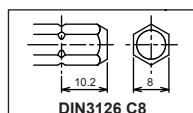

2138



Bit Holder
Klingenhalter
Porte-embouts

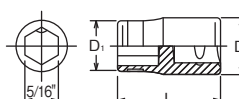

Hand Sockets Hand Steckschlüssel Douilles à main

1/4"

Z-SERIES
HAND
TITANIUM
SCREWDRIVERS ACCESSORIES
IMPACT
SLEEVE-DRIVE
PROTECTOR
INDUSTRIAL
AUTOMOTIVE
MOTORCYCLE
CONSTRUCTION
SPARE PART

2753PS Reversible Ratchet (Short)
Knarre kurz, verstellbar
Cliquet courte, réversible

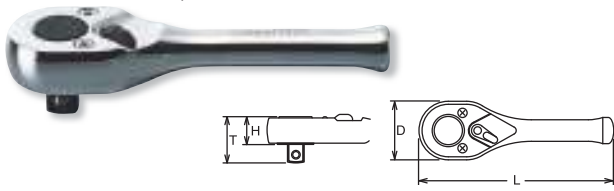

* Renewal Kits → 2753RK → P298

	D (mm)	T (mm)	H (mm)	L (mm)	(g)	(pcs.)
2753PS	22	18.7	11.4	75	55	5

2753J Reversible Ratchet
Knarre, verstellbar
Cliquet, réversible



* Renewal Kits → 2753RK → P298

	D (mm)	T (mm)	H (mm)	L (mm)	(g)	(pcs.)
2753J	22	18.7	11.4	115	77	5

2753P Reversible Ratchet
Knarre, verstellbar
Cliquet, réversible



* Renewal Kits → 2753RK → P298

	D (mm)	T (mm)	H (mm)	L (mm)	(g)	(pcs.)
2753P	22	18.7	11.4	115	87	10

2753N Reversible Ratchet
Knarre, verstellbar
Cliquet, réversible

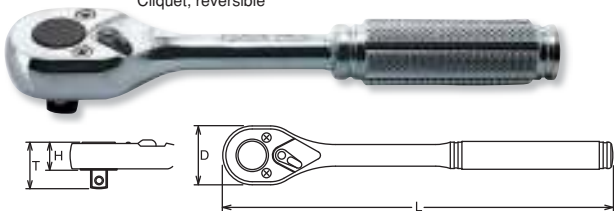

* Renewal Kits → 2753RK → P298

	D (mm)	T (mm)	H (mm)	L (mm)	(g)	(pcs.)
2753N	22	18.7	11.4	115	90	10

2753P-160 Reversible Ratchet (Long)
Verstellbare Knarre, lang
Cliquet réversible, longue

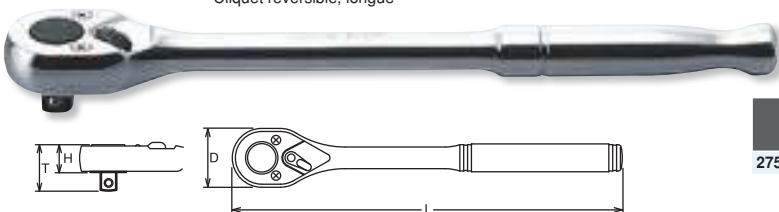

* Renewal Kits → 2753RK → P298

	D (mm)	T (mm)	H (mm)	L (mm)	(g)	(pcs.)
2753P-160	22	18.7	11.4	160	107	5

2753JB Reversible Ratchet with quick release button
Knarre, verstellbar mit Verriegelungsknopf
Cliquet, réversible avec bouton de débrayage



* Renewal Kits → 2753BRK → P298

2753PB Reversible Ratchet with quick release button
Knarre, verstellbar mit Verriegelungsknopf
Cliquet, réversible avec bouton de débrayage



* Renewal Kits → 2753BRK → P298

2753NB Reversible Ratchet with quick release button
Knarre, verstellbar mit Verriegelungsknopf
Cliquet, réversible avec bouton de débrayage

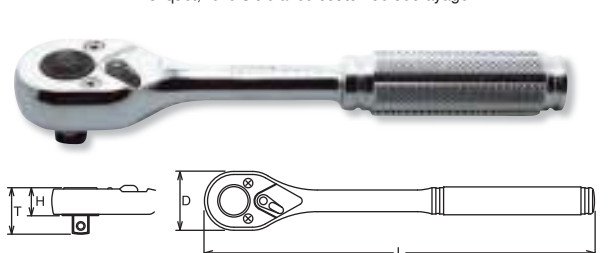

* Renewal Kits → 2753BRK → P298

	D (mm)	T (mm)	H (mm)	L (mm)	(g)	(pcs.)
2753JB	22	18.7	11.4	115	77	5
2753PB	22	18.7	11.4	115	87	10
2753NB	22	18.7	11.4	115	90	10

⚠ Reversible Ratchet with Quick Release Button :
Sockets and accessories are safely locked. By pushing the button the sockets or extension bars are released from the ratchet.

Umstellbare Knarre mit Verriegelungsknopf :
Steckschlüssel und Zubehörteile werden sicher und fest gehalten. Bei Drücken des Knopfes lösen sich die Teile.

Cliquet réversible à verrouillage :
Les douilles et accessoires ne peuvent plus tomber. Une pression du pouce sur le bouton suffit pour les libérer.



* Renewal Kits → 2753RK → P298



* Renewal Kits → 2753RK → P298

	D (mm)	T (mm)	H (mm)	L (mm)	(g)	(pcs.)
2774JS	22	18.7	11.4	116	113	5
2774PS	22	18.7	11.4	116	110	5



* Renewal Kits → 2753RK → P298



* Renewal Kits → 2753RK → P298



* Renewal Kits → 2753RK → P298

	D (mm)	T (mm)	H (mm)	L (mm)	(g)	(pcs.)
2774J	22	18.7	11.4	161	130	2
2774P	22	18.7	11.4	161	126	2
2774N	22	18.7	11.4	161	130	2



* Renewal Kits → 2755RK → P300

	D (mm)	L (mm)	(g)	(pcs.)
2755	26	40	80	10

	D (mm)	L (mm)	(g)	(pcs.)
2756	22	20	19	10

2774JS Flexible Ratchet, reversible
Gelenk-Knarre, verstellbar
Cliquet articulé, réversible



2774PS Flexible Ratchet, reversible
Gelenk-Knarre, verstellbar
Cliquet articulé, réversible

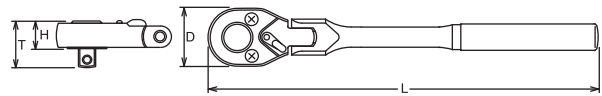

2774J Flexible Ratchet, reversible
Gelenk-Knarre, verstellbar
Cliquet articulé, réversible



2774P Flexible Ratchet, reversible
Gelenk-Knarre, verstellbar
Cliquet articulé, réversible



2774N Flexible Ratchet, reversible
Gelenk-Knarre, verstellbar
Cliquet articulé, réversible

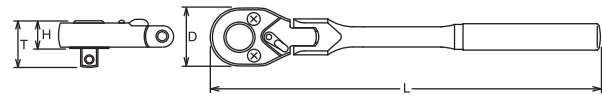

2755 Ratchet Adaptor
Aufsteckknarre
Cliquet adaptable

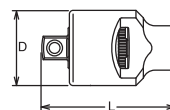

2756 Quick Spinner
Rändel-Drehscheibe
Lanceur

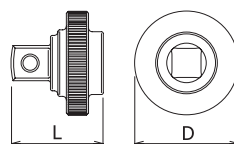

Z-SERIES
HAND
TITANIUM
SCREWDRIVERS ACCESSORIES
IMPACT
SLEEVE-DRIVE
PROTECTOR
INDUSTRIAL
AUTOMOTIVE
MOTORCYCLE
CONSTRUCTION
SPARE PART

2760-28/-50/-75/-100/-150/-200/-250/ -300/-350/-400/-600

Extension Bars
Verlängerungen
Rallonges

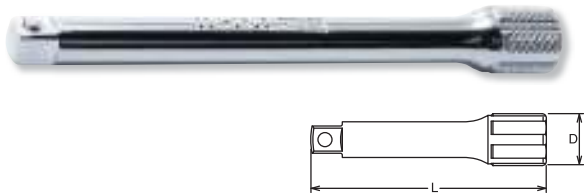

PK2760/6

Extension Set in Plastic Box
Verlängerungen in Kunststoffkassette
Jeu de rallonges en boîte plastique



2760	D (mm)	L (mm)	(g)	(pcs.)
28	12.3	28	14	10
50	12.3	50	23	10
75	12.3	75	35	10
100	12.3	100	44	10
150	12.3	150	63	10
200	12.3	200	83	10
250	12.3	250	103	10
300	12.3	300	122	2
350	12.3	350	145	2
400	12.3	400	160	2
600	12.3	600	240	2

PK2760/6 6 Pieces Set/△=430g

PLASTIC TRAY

Extension Bars
2760 Extension Bars 28, 50, 100, 150, 200, 250

Rotation and general handling of extensions with oily hands is greatly improved with the **Koken** developed 6 point knurling. Also the **Koken** 6 point knurling stops the extensions from rolling around the work area.

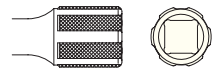

Durch die von **Koken** entwickelte 6 fache Rändelung wird die Handhabung deutlich erleichtert. Außerdem wird das Herumrollen der Verlängerungen wirksam verhindert.

La manipulation des rallonges est grandement facilitée par le profil moleté développé par **Koken**. Ce même profil empêche le roulement intempestif des rallonges sur le plan de travail.

2763-28/-50/-75/-100/-150/ -200/-250



Wobble-Fix Extension Bars
Winkel-Verlängerungen
Rallonges angulaires

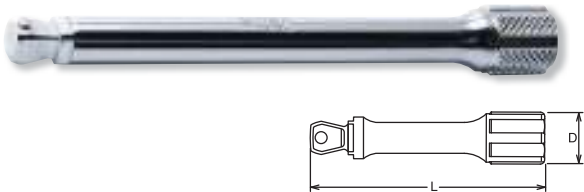

PK2763/6

Wobble-Fix Extension Bars in Plastic Box
Winkel-Verlängerungen in Kunststoffkassette
Jeu de rallonges angulaires en boîte plastique



2763	D (mm)	L (mm)	(g)	(pcs.)
28	12.3	28	14	10
50	12.3	50	23	10
75	12.3	75	33	10
100	12.3	100	43	10
150	12.3	150	62	10
200	12.3	200	80	10
250	12.3	250	100	10

PK2763/6 6 Pieces Set/△=420g

PLASTIC TRAY

Extension Bars
2763 Wobble-Fix Extension Bars 28, 50, 100, 150, 200, 250

Wobble-Fix Extension Bar
Two way usage
a) In a fixed position, as a normal extension bar
b) In a half-fixed position, as a flexible extension bar providing a 15° angle operation

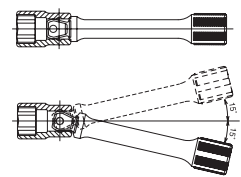

Winkel-Verlängerungen
Winkelverlängerungen lassen sich in zwei Einstellungen verwenden
a) voll eingesteckt und starr,
b) halb eingesteckt, mit einem Arbeitswinkel von 15°.

Rallonges angulaires
Deux utilisations possibles
a) comme rallonge normale, dans une position fixe
b) comme une rallonge angulaire avec une possibilité d'inclinaison jusqu'à 15°

⚠ The Wobble-Fix Extension Bar has less strength than normal extension bar due to it's specific design with a reduced square drive. Make sure to use it correctly.

2762 Flexible Extension Bar Biegsame Verlängerung Rallonge flexible

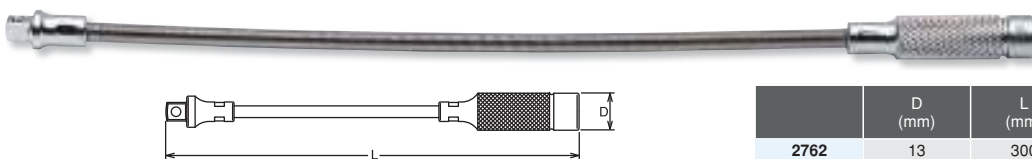

2762	D (mm)	L (mm)	(g)	(pcs.)
2762	13	300	90	2

2120 Magnetic Head Magnetkopf Tête aimantée

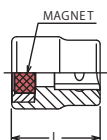

2120	L (mm)	(g)	(pcs.)
2120	17.5	21	10

* Renewal Kits → 2768RK → P300

	D (mm)	L (mm)	(g)	(pcs.)
2768J	14	130	73	5
2768P	14	130	70	10

* Renewal Kits → 2768RK → P300

2769N	ℓ (mm)	L (mm)	(g)	(pcs.)
150	50	150	68	2
220	120	220	100	2



Plastic or rubber handles are not intended to act as insulation.

Plastik-oder Gummigriffe stellen keinen Isolierschutz dar.

Les poignées en plastique ou en caoutchouc ne garantissent aucune isolation électrique.



2769NWF	ℓ (mm)	L (mm)	(g)	(pcs.)
150	50	150	68	2
220	120	220	100	2

	L (mm)	(g)	(pcs.)
2769H	160	180	10

2768J Hinge Handle
Gelenkgriff
Poignée articulée



2768P Hinge Handle
Gelenkgriff
Poignée articulée

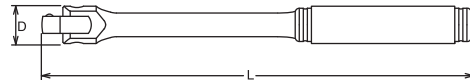

2769N-150/-220 Spin Type Handle
Drehgriff
Poignée emmanchée

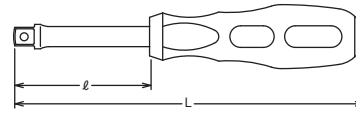

2769NWF-150/-220

Spin Type Handle (Wobble-Fix)
Drehgriff, Wobble-Fix
Poignée emmanchée, angulaire

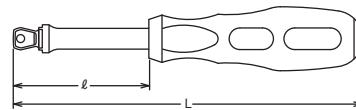

2769H Folding Socket Driver
Klapp-Drehgriff
Poignée tournevis articulée

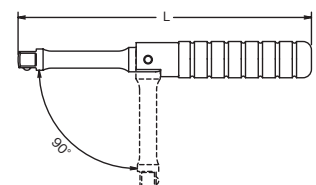

Hand Sockets
Hand Steckschlüssel
Douilles à main

1/4"

Z-SERIES
HAND
TITANIUM
SCREWDRIVERS ACCESSORIES
IMPACT
SLEEVE-DRIVE
PROTECTOR
INDUSTRIAL
AUTOMOTIVE
MOTORCYCLE
CONSTRUCTION
SPARE PART

2770 Universal Joint
Gelenk-Einsatz
Cardan universel



	L (mm)	(g)	(pcs.)
2770	33	20	10
2771	31	20	10

2771 Universal Joint
Gelenk-Einsatz
Joint articlé



2780 Speed Handle
Winde
Vilebrequin

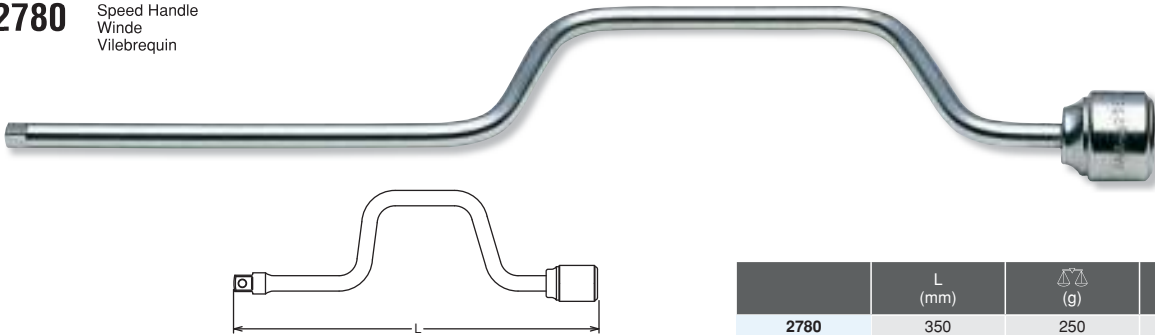

	L (mm)	(g)	(pcs.)
2780	350	250	1

2785 T-Handle
T-Griff
Poignée coulissante

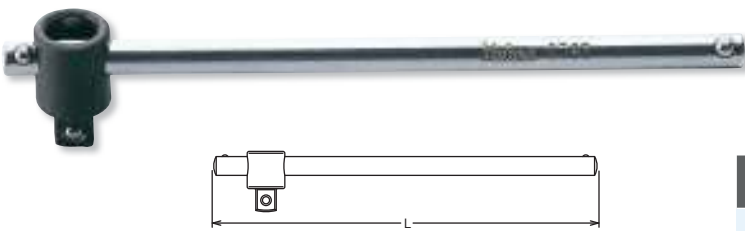





	L (mm)	(g)	(pcs.)
2785	115	36	10

2233A Adaptor
Verbindungsstück
Augmentateur







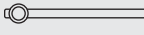





	(sq.)	(sq.)	L (mm)	(g)	(pcs.)
2233A	1/4"	3/8"	22	16	10

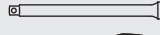

ESH2001		16 Pieces Set/△△=630g	
METAL CASE:W160×H100×T28mm			
Sockets	Accessories		
 2410M Surface Drive Sockets 4, 5, 5.5, 6, 7, 8, 9, 10, 11, 12, 13	 2753J	 2763-50	 2760-150
	 2770	 2785	





ESH2001 Socket Set
Steckschlüssel Satz
Jeu de clés à douille



ENH2003		26 Pieces Set/△△=980g	
METAL CASE:W310×H86×T40mm			
Sockets	Accessories		
 2400M 6-pt. Sockets 5.5, 6, 7, 8, 9, 10, 11, 12, 13, 14	 2753J	 2760-50	 2760-150
 108P Phillips Bits 1, 2	 2769N-150	 2770	 2785
 108S Slotted Bits 4, 6, 8	 2137		
 108H Hex Bits 3, 4, 5, 6			



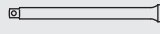
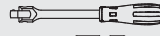

ENH2003 Socket Set
Steckschlüssel Satz
Jeu de clés à douille





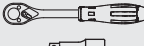

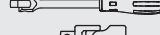

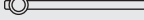



2251M		17 Pieces Set/△△=725g	
METAL CASE:W192×H122×T30mm			
Sockets	Accessories		
 2400M 6-pt. Sockets 4, 4.5, 5, 5.5, 6, 7, 8, 9, 10, 11, 13	 2753J	 2760-50	 2760-150
	 2768J	 2770	 2785

2251M / 2251A Socket Set
Steckschlüssel Satz
Jeu de clés à douille



2251A		15 Pieces Set/△△=700g	
METAL CASE:W192×H122×T30mm			
Sockets	Accessories		
 2400A 6-pt. Sockets 3/16, 7/32, 1/4, 9/32, 5/16, 11/32, 3/8, 7/16, 1/2	 2753J	 2760-50	 2760-150
	 2768J	 2770	 2785

2258M Socket Set
Steckschlüssel Satz
Jeu de clés à douille

2258M		31 Pieces Set/△△=965g	
METAL CASE:W240×H100×T32mm			
Sockets	Accessories		
 2400M 6-pt. Sockets 4, 4.5, 5, 5.5, 6, 7, 8, 9, 10, 11, 13	 2753J	 2760-100	 2769N-150
 2000.28 Bit Sockets 1, 2, 3	 2770	 2785	
 2005.25 Bit Sockets 4, 6			
 2010M.25 Bit Sockets 3, 4, 5, 6, 8			
 2025.28 Bit Sockets T10, T15, T20, T25, T30			



Hand Sockets Hand Steckschlüssel Douilles à main

1/4"

Z-SERIES
HAND
TITANIUM
SCREWDRIVERS ACCESSORIES
IMPACT
SLEEVE-DRIVE
PROTECTOR
INDUSTRIAL
AUTOMOTIVE
MOTORCYCLE
CONSTRUCTION
SPARE PART

2259M Socket Set
Steckschlüssel Satz
Jeu de clés à douille



2259M		31 Pieces Set/△=991g	
METAL CASE:W240xH100xT32mm			
Sockets		Accessories	
	2400M 6-pt. Sockets 4, 4.5, 5, 5.5, 6, 7, 8, 9, 10, 11, 13		2774JS
	2000.28 Bit Sockets 1, 2, 3		2760-100
	2005.25 Bit Sockets 4, 6		2769N-150
	2010M.25 Bit Sockets 3, 4, 5, 6, 8		2770
	2025.28 Bit Sockets T10, T15, T20, T25, T30		2785

2263A Socket Set
Steckschlüssel Satz
Jeu de clés à douille



2263A		29 Pieces Set/△=940g	
METAL CASE:W240xH100xT32mm			
Sockets		Accessories	
	2400A 6-pt. Sockets 1/8, 5/32, 3/16, 7/32, 1/4, 9/32, 5/16, 11/32, 3/8, 7/16, 1/2		2753N
	2000.28 Bit Sockets 1, 2, 3		2760-100
	2010A.25 Bit Sockets 1/8, 5/32, 3/16, 7/32, 1/4, 9/32, 5/16		2769N-150
	2025.28 Bit Sockets T10, T15, T20, T25, T30		2770
			2785

2275 Socket Set
Steckschlüssel Satz
Jeu de clés à douille



2275		19 Pieces Set/△=880g	
METAL CASE:W192xH122xT30mm			
Sockets		Accessories	
	2400M 6-pt. Sockets 5.5, 6, 7, 8, 10, 12, 13		2753J
	2000.28 Bit Sockets 1, 2, 3		2763-50
	2005.25 Bit Sockets 6, 8		2769N-150
	2010M.25 Bit Sockets 3, 4, 5, 6		

2276 Socket Set with Bits and Accessories
Bit Satz mit Zubehör
Jeu d'embouts et avec accessoires





2276		19 Pieces Set/△=640g	
METAL CASE:W192xH122xT30mm			
Bits		Accessories	
	108P Phillips Bits 1, 2, 3		2753PS
	108S Slotted Bits 4, 5, 6		2769N-150
	108H Hex Bits 3, 4, 5, 6		2137
	108T TORX® Bits T10, T15, T20, T25, T27, T30		

2277 Socket Set
Steckschlüssel Satz
Jeu de clés à douille



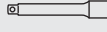

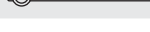

2277		21 Pieces Set/△=1,240g	
METAL CASE:W310xH86xT50mm			
Sockets		Accessories	
	2400M 6-pt. Sockets 5.5, 6, 7, 8, 9, 10, 11, 12, 13		2753J
	2300M 6-pt. Deep Sockets 5.5, 6, 7, 8, 9, 10, 11, 12, 13		2763-75
			2769N-150

P2201AM		25 Pieces Set/△=800g	
PLASTIC CASE:W245xH120xT45mm			
Sockets	Accessories		
2400M 6-pt. Sockets 4, 5, 5.5, 6, 7, 8, 9, 10, 11, 12, 13 2400A 6-pt. Sockets 3/16, 7/32, 1/4, 9/32, 5/16, 11/32, 3/8, 7/16, 1/2		2753J	
		2760-100	
		2769N-150	
		2770	
		2785	

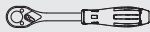

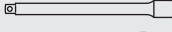
P2201AM Socket Set
Steckschlüssel Satz
Jeu de clés à douille

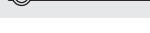

P2251M		18 Pieces Set/△=770g	
PLASTIC CASE:W245xH120xT45mm			
Sockets	Accessories		
2400M 6-pt. Sockets 4, 4.5, 5, 5.5, 6, 7, 8, 9, 10, 11, 12, 13		2753J	
		2760-50	
		2760-150	
		2768J	
		2770	
		2785	

P2251M Socket Set
Steckschlüssel Satz
Jeu de clés à douille

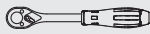
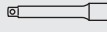

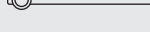
P2258M		31 Pieces Set/△=860g	
PLASTIC CASE:W245xH120xT45mm			
Sockets	Accessories		
2400M 6-pt. Sockets 4, 5, 5.5, 6, 7, 8, 9, 10, 11, 12, 13 2000.28 Bit Sockets 1, 2, 3 2005.25 Bit Sockets 4, 6 2010M.25 Bit Sockets 3, 4, 5, 6, 8 2025.28 Bit Sockets T10, T15, T20, T25, T30		2753J	
		2760-100	
		2769N-150	
		2770	
		2785	

P2258M Socket Set
Steckschlüssel Satz
Jeu de clés à douille



ABS Case - PE foam insert
Kunststoffkassette - Weichschaumeinlage
Coffret en ABS - Inserts en mousse

3400M / 3400A 6-point Sockets 6-kant Steckschlüssel Douilles 6-pans

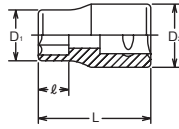

3405M / 3405A 12-point Sockets 12-kant Steckschlüssel Douilles 12-pans

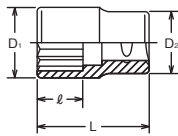

FLAT DRIVE®

Flat drive is designed to guarantee a flat surface contact between the socket and the bolt/nut. The Flat contact reduces wear and allows to transmit a higher torque value. The Flat Drive System is also used for the square drive end as well as the hexagonal or bi-hexagonal openings of the socket.

Das Flat Drive Design sorgt für die optimale Kraftübertragung zwischen den Flächen des Steckschlüssels und der Schraube. Dies erlaubt eine Übertragung von höheren Drehmomenten. Das Flat Drive System findet ebenfalls bei allen Antriebsvierkanten sowie bei 6-kant und 12-kant Profilen Verwendung.



Le profil Flat Drive garantit un contact optimal entre la douille et l'écrou. Ce contact « à plat » réduit l'usure et permet la transmission d'un couple plus élevé. Ce système Flat Drive est utilisé pour tous les carrés conducteurs ainsi que pour toutes nos douilles 6-pans et 12-pans.



RS3400M/12 Socket Set on Rail Steckschlüsselsatz auf Schiene Jeu de douilles sur rail



RS3400A/9 Socket Set on Rail Steckschlüsselsatz auf Schiene Jeu de douilles sur rail



3400M 3405M (mm)	D ₁ (mm)	D ₂ (mm)	ℓ (mm)	L (mm)	 (g)	 (pcs.)
5	8.3	17.3	5	26	20	10
5.5	8.9	17.3	5.5	26	20	10
6	9.9	17.3	6	26	20	10
7	10.8	17.3	6.5	26	20	10
8	12	17.3	7	26	22	10
9	13.3	17.3	7.5	26	23	10
10	14.5	17.3	8	26	24	10
11	15.8	17.3	8.5	26	25	10
12	16.8	17.3	9	26	25	10
13	18	17	9.5	26	24	10
14	19.5	18.5	11	27	31	10
15	20.8	19.5	11.5	28	39	10
16	22	20	12	28	42	10
17	23.3	21.5	12.5	29	51	10
18	24.5	22.5	13	30	51	10
19	25.8	23.5	13.5	30	63	10
20	27	24.5	14	31	75	10
21	28	26	14.5	32	77	10
22	29.5	26.5	15	32	82	10
23	30.8	27.5	15.5	33	95	10
24	32	28.5	16	34	102	10
25	33.3	29.5	16.5	34	115	10
26	34.5	30.5	17	35	129	10

3400A 3405A (inch)	D ₁ (mm)	D ₂ (mm)	ℓ (mm)	L (mm)	 (g)	 (pcs.)
3/16	8.3	17.3	5	26	20	10
1/4	10.3	17.3	6	26	20	10
9/32	10.8	17.3	6.5	26	20	10
5/16	12	17.3	7	26	22	10
11/32	13.3	17.3	7.5	26	23	10
3/8	13.9	17.3	8	26	23	10
13/32	13.3	17.3	7.5	26	23	10
7/16	15.8	17.3	8.5	26	25	10
1/2	18	17	9.5	26	24	10
9/16	19.5	18.5	11	27	31	10
19/32	20.8	19.5	11.5	28	39	10
5/8	22	20	12	28	42	10
11/16	24.5	22.5	13	30	51	10
3/4	25.8	23.5	13.5	30	63	10
25/32	27	24.5	14	31	75	10
13/16	28	26	14.5	32	77	10
7/8	29.5	26.5	15	32	82	10
15/16	32	28.5	16	34	102	10
1	34.5	30.5	17	35	132	10

RS3400M/12	12 Pieces Set/Rail 300mm	 (g)
8, 9, 10, 11, 12, 13, 14, 15, 16, 17, 18, 19		465

RS3405M/12	12 Pieces Set/Rail 300mm	 (g)
8, 9, 10, 11, 12, 13, 14, 15, 16, 17, 18, 19		465

RS3400A/9	9 Pieces Set/Rail 200mm	 (g)
1/4, 5/16, 3/8, 7/16, 1/2, 9/16, 5/8, 11/16, 3/4		333

RS3405A/9	9 Pieces Set/Rail 200mm	 (g)
1/4, 5/16, 3/8, 7/16, 1/2, 9/16, 5/8, 11/16, 3/4		333

3410M (mm)	D ₁ (mm)	D ₂ (mm)	ℓ (mm)	L (mm)	(g)	(pcs.)
5.5	8.9	17.3	5.5	26	20	10
6	9.9	17.3	6	26	20	10
7	10.8	17.3	6.5	26	20	10
8	12	17.3	7	26	22	10
9	13.3	17.3	7.5	26	23	10
10	14.5	17.3	8	26	24	10
11	15.8	17.3	8.5	26	25	10
12	16.8	17.3	9	26	25	10
13	18	17	9.5	26	24	10
14	19.5	18.5	11	27	31	10
15	20.8	19.5	11.5	28	39	10
16	22	20	12	28	42	10
17	23.3	21.5	12.5	29	51	10
18	24.5	22.5	13	30	51	10
19	25.8	23.5	13.5	30	63	10
20	27	24.5	14	31	75	10
21	28	26	14.5	32	77	10
22	29.5	26.5	15	32	82	10
23	30.8	27.5	15.5	33	95	10
24	32	28.5	16	34	102	10

RS3410M/12	12 Pieces Set/Rail 300mm	(g)
8, 9, 10, 11, 12, 13, 14, 15, 16, 17, 18, 19		468

3400W 3405W (W)	D ₁ (mm)	D ₂ (mm)	ℓ (mm)	L (mm)	(g)	(pcs.)
1/8	13.3	17.3	7.5	26	22	10
3/16	15.8	17.3	8.5	26	25	10
1/4	18	17	9.5	26	24	10
5/16	20.8	19.5	11.5	28	39	10
3/8	24.5	22.5	13	30	51	10
7/16	28	26	14.5	32	81	10
1/2	30.8	27.5	15.5	33	103	10
9/16	34.5	30.5	17	35	128	10

BS W	S	BS · W													
		BS	3/16BS	1/4BS	5/16BS	3/8BS	7/16BS	1/2BS	9/16BS	5/8BS	11/16BS	3/4BS	7/8BS		
		W	1/8W	3/16W	1/4W	5/16W	3/8W	7/16W	1/2W	9/16W	5/8W	11/16W	3/4W		
Across Flat	(ref. mm)	8.6	11.3	13.3	15.2	18.0	20.8	23.4	25.7	27.9	30.5	33.0			

RS3400W/7	7 Pieces Set/Rail 200mm	(g)
1/8, 3/16, 1/4, 5/16, 3/8, 7/16, 1/2		389

RS3405W/7	7 Pieces Set/Rail 200mm	(g)
1/8, 3/16, 1/4, 5/16, 3/8, 7/16, 1/2		389

3410M Surface Drive Sockets Surface Drive Steckschlüssel Douilles, Surface Drive

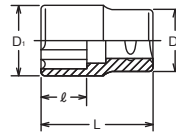

SURFACE DRIVE

Surface drive sockets are designed to retain contact with the flat sides of the nut in order to transmit higher torque and reduce nut wear. These sockets are ideal for using on polished nuts, aluminum nuts and nuts with worn out points.

Das Profil unserer Surface-Drive Steckschlüssel greift die Schraube an deren Flächen. Dies sichert eine höhere Kraftübertragung und verhindert ein Durchrutschen des Steckschlüssels. Diese Steckschlüssel eignen sich besonders für polierte Schrauben, Aluminium Schrauben und Schrauben bei denen die Ecken bereits abgerundet sind.

Notre profil Surface Drive assure le contact entre la douille et les plats de l'écrou. Ceci réduit l'usure et permet la transmission d'un couple plus élevé. C'est une solution idéale pour les écrous polis, celles en aluminium ou arrondies.

RS3410M/12 Socket Set on Rail Steckschlüsselsatz auf Schiene Jeu de douilles sur rail



3400W 6-point Whitworth Sockets 6-kant Steckschlüssel, Whitworth Douilles à 6-pans Whitworth

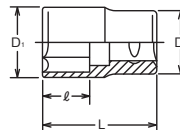

3405W 12-point Whitworth Sockets 12-kant Steckschlüssel, Whitworth Douilles à 12-pans Whitworth

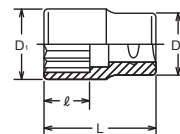

RS3400W/7 Socket Set on Rail Steckschlüsselsatz auf Schiene Jeu de douilles sur rail

RS3405W/7 Socket Set on Rail Steckschlüsselsatz auf Schiene Jeu de douilles sur rail



Z-SERIES
HAND
TITANIUM
SCREWDRIVERS ACCESSORIES
IMPACT
SLEEVE-DRIVE
PROTECTOR
INDUSTRIAL
AUTOMOTIVE
MOTORCYCLE
CONSTRUCTION
SPARE PART

3415M / 3415A

 Double 4-point Sockets
Doppelvierkant Steckschlüssel
Douilles 4-pans, doubles

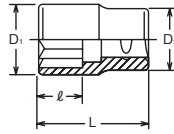

	3415M (mm)	D ₁ (mm)	D ₂ (mm)	ℓ (mm)	L (mm)	(g)	(pcs.)
New	5.5	10.8	17.4	5.5	26	21	10
	6	12	17.3	6	26	26	10
New	7	13.3	17.4	6.5	26	26	10
	8	14.5	17.3	7	26	26	10
	10	16.8	17.3	8	26	27	10
	12	20.8	19.5	9	27	43	10
New	13	21.9	20	9.5	27	46	10

	3415A (inch)	D ₁ (mm)	D ₂ (mm)	ℓ (mm)	L (mm)	(g)	(pcs.)
	1/4	12	17.3	6	26	24	10
	5/16	14.5	17.3	7	26	26	10
	11/32	15.8	17.3	7.5	26	27	10
	3/8	16.8	17.3	8	26	27	10
	7/16	19.5	18.5	8.5	27	37	10
	1/2	22	20	9.5	27	46	10

3425

 TORX® Sockets
TORX® Steckschlüssel
Douilles TORX®

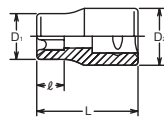

	3425 (E)	D ₁ (mm)	D ₂ (mm)	ℓ (mm)	L (mm)	(g)	(pcs.)
	E 4	5.6	17.3	4.6	26	18	10
	E 5	7	17.3	5.2	26	20	10
	E 6	8.3	17.3	5.4	26	21	10
	E 7	8.9	17.3	6.6	26	22	10
	E 8	9.9	17.3	7	26	23	10
	E10	12	17.3	8.2	26	24	10
	E11	13.3	17.3	8.7	26	25	10
	E12	14.5	17.3	9.3	26	26	10
	E14	15.8	17.3	10.6	26	27	10
	E16	18	17	11.8	26	27	10

TORX® (E)

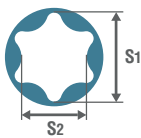

	E	E4	E5	E6	E7	E8	E10	E11	E12	E14	E16	E18	E20	E22	E24	E26	E28
S ₁	(ref. mm)	3.7	4.6	5.6	6.1	7.4	9.3	9.9	11.0	12.8	14.6	16.5	18.3	20.1	22.0	23.7	25.5
S ₂	(ref. mm)	2.7	3.3	4.0	4.3	5.3	6.8	7.1	7.9	9.2	10.5	11.9	13.2	14.8	15.7	17.5	18.3

RS3425/9

 Socket Set on Rail
Steckschlüsselsatz auf Schiene
Jeu de douilles sur rail



RS3425/9	9 Pieces Set/Rail 200mm	(g)
E4, E5, E6, E7, E8, E10, E12, E14, E16		239

RSX425/14

 Socket Set on Rail
Steckschlüsselsatz auf Schiene
Jeu de douilles sur rail



RSX425/14	14 Pieces Set/Rail 300mm	(g)
2425	1/4" E4, E5, E6, E7, E8	550
3425	3/8" E10, E11, E12, E14	
4425	1/2" E16, E18, E20, E22, E24	

3400LH

 LHSTIX® Sockets
Steckschlüssel mit LHSTIX® Profil
Douilles au profil LHSTIX®

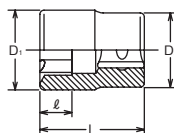

3400LH (LH-S)	D ₁ (mm)	D ₂ (mm)	ℓ (mm)	L (mm)	(g)	(pcs.)
5S	10.8	17.3	5	26	20	10
6S	12	17.3	5.6	26	22	10
8S	15.8	17.3	6.8	26	25	10
10S	18	17	8	26	25	10
12S	22	20	9.2	28	42	10
14S	24.5	22.5	10.4	30	51	10
16S	28	26	11.6	32	77	10

TORX is a registered trademark of Acument Intellectual Properties, LLC.
TORX ist ein registriertes Markenzeichen der Firma Acument Intellectual Properties, LLC.
TORX est une marque déposée de Acument Intellectual Properties, LLC.

LHSTIX is a registered trademark of OSG CORPORATION System Engineering Department.
LHSTIX ist ein registriertes Markenzeichen der Firma OSG CORPORATION System Engineering Department.
LHSTIX est une marque déposée de OSG CORPORATION System Engineering Department.

RS3400LH/7	7 Pieces Set/Rail 150mm	 (g)
5S, 6S, 8S, 10S, 12S, 14S, 16S		315



RS3400LH/7   Socket Set on Rail
Steckschlüsselsatz auf Schiene
Jeu de douilles sur rail

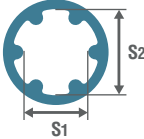

LHSTIX®



LH-S	LH-5S	LH-6S	LH-8S	LH-10S	LH-12S	LH-14S	LH-16S
S ₁ (ref. mm)	5.6	6.8	9.0	11.3	13.6	15.8	18.1
S ₂ (ref. mm)	7.5	9.0	12.0	15.0	18.0	21.0	24.0

3450M (mm)	D ₁ (mm)	D ₂ (mm)	ℓ (mm)	L (mm)	 (g)	 (pcs.)
8	12	17.3	5	26	21	10
10	14.5	17.3	6	26	24	10
11	15.8	17.3	6.5	26	26	10
12	16.8	17.3	7	26	26	10
13	18	17	8	26	28	10
14	19.5	18.5	8.5	27	34	10
15	20.8	19.5	9	27	42	10
16	22	20	9	27	50	10
17	23.3	21.5	9.5	28	62	10
18	24.5	22.5	10.5	29	64	10
19	25.8	23.3	11.5	29	66	10
21	28	26	12	29	85	10
22	29.5	27	12.5	29	90	10
24	32	30	14.5	31	102	10

3450M  Nut Grip Sockets **Nut Grip®**
Steckschlüssel mit 2-facher Kugelhalterung
Douilles à billes de retenue

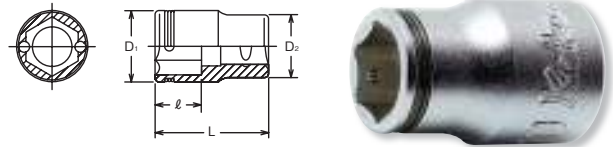

NUT GRIP®

Twin balls at the 6-point opening hold bolt/nut tightly for safe and reliable work.

Die zwei Kugeln in der 6-kant Öffnung unserer NUT GRIP Steckschlüssel halten die Schraube sicher im Steckschlüssel. Dies erlaubt ein Arbeiten auch an schwer zugänglichen Stellen.



Les 2 billes dans l'ouverture du 6-pans de la douille retiennent l'écrou de manière sûre et efficace.

RS3450M/8	8 Pieces Set/Rail 200mm	 (g)
8, 10, 11, 12, 13, 14, 17, 19		310





RS3450M/8   Socket Set on Rail
Steckschlüsselsatz auf Schiene
Jeu de douilles sur rail

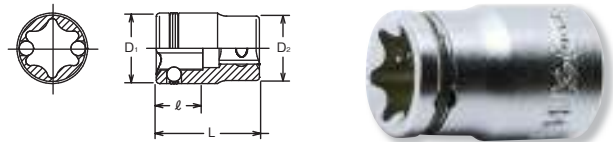

3425 (2B)	D ₁ (mm)	D ₂ (mm)	ℓ (mm)	L (mm)	 (g)	 (pcs.)
E10	12	17.3	8.2	26	23	10
E12	14.5	17.3	9.3	26	25	10
E14	15.8	17.3	10.6	26	26	10
E16	18.1	17	11.8	26	27	10
E18	19.5	18.5	12	32	41	10
E20	21.9	20	14.4	32	52	10

3425 (2B)  TORX® Sockets **Nut Grip®**
TORX Steckschlüssel mit 2-facher Kugelhalterung
Douilles Torx à deux billes de retenue



RS3425/4(2B)	4 Pieces Set/Rail 150mm	 (g)
E10, E12, E14, E20		150

RS3425/4 (2B)   Socket Set on Rail
Steckschlüsselsatz auf Schiene
Jeu de douilles sur rail



TORX is a registered trademark of Acument Intellectual Properties, LLC.
TORX ist ein registriertes Markenzeichen der Firma Acument Intellectual Properties, LLC.
TORX est une marque déposée de Acument Intellectual Properties, LLC.

LHSTIX is a registered trademark of OSG CORPORATION System Engineering Department.
LHSTIX ist ein registriertes Markenzeichen der Firma OSG CORPORATION System Engineering Department.
LHSTIX est une marque déposée de OSG CORPORATION System Engineering Department.

Z-SERIES
HAND
TITANIUM
SCREWDRIVERS ACCESSORIES
IMPACT
SLEEVE-DRIVE
PROTECTOR
INDUSTRIAL
AUTOMOTIVE
MOTORCYCLE
CONSTRUCTION
SPARE PART

3300X / 3300XA

6-point Sockets, Semi-Deep
6-kant Steckschlüssel, mittel-lang
Douilles, semi-profondes 6-pans



3300X 3305X (mm)	D ₁ (mm)	D ₂ (mm)	ℓ (mm)	H (mm)	L (mm)	(g)	(pcs.)
8	12	17.3	9	26.5	40	34	10
9	13	17.3	10	26.5	40	36	10
10	14.5	17.3	11	26.5	40	36	10
11	16	17.2	12	26.5	40	36	10
12	16.8	17.2	13	26.5	40	36	10
13	18	17	14	26.5	40	37	10
14	20	18	16	26.5	40	46	10
15	21	20	16	25.5	40	49	10
16	22	20	17	25.5	40	51	10
17	23.5	22	18	25.5	40	61	10
18	24.5	23	19	24.5	40	68	10
19	25	24	20	24.5	40	75	10

3305X / 3305XA

12-point Sockets, Semi-Deep
12-kant Steckschlüssel, mittel-lang
Douilles, semi-profondes 12-pans



3300XA 3305XA (inch)	D ₁ (mm)	D ₂ (mm)	ℓ (mm)	H (mm)	L (mm)	(g)	(pcs.)
1/4	10.3	17.3	7	26.5	40	32	10
5/16	12	17.3	9	26.5	40	34	10
3/8	13.9	17.3	11	26.5	40	36	10
7/16	16	17.2	12	26.5	40	36	10
1/2	18	17	14	26.5	40	37	10
9/16	20	18.5	16	26.5	40	46	10
5/8	22	20	17	25.5	40	51	10
11/16	24.5	22.5	19	24.5	40	68	10
3/4	25	23.5	20	24.5	40	75	10

RS3300X/8 RS3305X/8

Socket Set on Rail
Steckschlüsselsatz auf Schiene
Jeu de douilles sur rail



RS3300X/8	8 Pieces Set/Rail 200mm	(g)
8, 10, 11, 12, 13, 14, 17, 19		405

RS3305X/8	8 Pieces Set/Rail 200mm	(g)
8, 10, 11, 12, 13, 14, 17, 19		405

RS3300XA/9 RS3305XA/9

Socket Set on Rail
Steckschlüsselsatz auf Schiene
Jeu de douilles sur rail



RS3300XA/9	9 Pieces Set/Rail 200mm	(g)
1/4, 5/16, 3/8, 7/16, 1/2, 9/16, 5/8, 11/16, 3/4		460

RS3305XA/9	9 Pieces Set/Rail 200mm	(g)
1/4, 5/16, 3/8, 7/16, 1/2, 9/16, 5/8, 11/16, 3/4		460

3350X

Nut Grip Socket, Semi-Deep **Nut Grip®**
Steckschlüssel mit 2-facher Kugelhalterung, mittel-lang
Douilles à billes de retenue, semi-profondes



3350X (mm)	D ₁ (mm)	D ₂ (mm)	ℓ (mm)	H (mm)	L (mm)	(g)	(pcs.)
8	12	17.4	5	26.5	40	33	10
10	14.5	17.4	6	26.5	40	35	10
12	16.8	17.2	7	26.5	40	40	10
14	19.5	18.5	8.5	26.5	40	48	10

RS3350X/4

Socket Set on Rail
Steckschlüsselsatz auf Schiene
Jeu de douilles sur rail



RS3350X/4	4 Pieces Set/Rail 150mm	(g)
8, 10, 12, 14		165

3300M 3305M (mm)	D ₁ (mm)	D ₂ (mm)	ℓ (mm)	H (mm)	L (mm)	(g)	(pcs.)
5.5	8.9	17.3	6.5	41.5	55	37	10
6	9.9	17.3	7	41.5	55	37	10
7	10.6	17.3	8	41.5	55	37	10
8	12	17.3	9	41.5	55	40	10
9	13	17.3	10	41.5	55	42	10
10	14.5	17.3	11	41.5	55	46	10
11	16	17.2	12	41.5	55	51	10
12	16.8	17.2	13	41.5	55	52	10
13	18	17	14	41.5	55	53	10
14	20	18	16	41.5	55	60	10
15	21	20	16	40.5	55	74	10
16	22	20	17	40.5	55	76	10
17	23.5	22	18	40.5	55	93	10
18	24.5	23	19	39.5	55	98	10
19	25	24	20	39.5	55	98	10
20	26	25	21	49.5	65	126	10
21	27	26	22	49.5	65	126	10
22	29	28	23	48.5	65	163	10
23	30	29	24	48.5	65	168	10
24	31	30	25	47.5	65	191	10
25	33	30	26	47.5	65	199	10
26	34	31	27	47.5	65	209	10
27	35	32.5	28	47.5	65	218	10

3300A 3305A (inch)	D ₁ (mm)	D ₂ (mm)	ℓ (mm)	H (mm)	L (mm)	(g)	(pcs.)
7/32	8.9	17.3	6	41.5	55	35	10
1/4	9.9	17.3	7	41.5	55	37	10
5/16	12	17.3	9	41.5	55	40	10
11/32	12.3	17.3	10	41.5	55	41	10
3/8	14	17.3	11	41.5	55	46	10
7/16	16	17.2	12	41.5	55	51	10
1/2	18	17	14	41.5	55	53	10
9/16	20	18	16	41.5	55	60	10
19/32	21	20	16	40.5	55	74	10
5/8	22	20	17	40.5	55	76	10
11/16	23.5	22	18	40.5	55	93	10
3/4	25	24	20	39.5	55	98	10
13/16	27	26	22	49.5	65	126	10
7/8	29	28	23	48.5	65	163	10
15/16	31	30	25	47.5	65	191	10

RS3300M/12	12 Pieces Set/Rail 300mm	(g)
8, 9, 10, 11, 12, 13, 14, 15, 16, 17, 18, 19		878

RS3305M/12	12 Pieces Set/Rail 300mm	(g)
8, 9, 10, 11, 12, 13, 14, 15, 16, 17, 18, 19		878

RS3300A/9	9 Pieces Set/Rail 200mm	(g)
1/4, 5/16, 3/8, 7/16, 1/2, 9/16, 5/8, 11/16, 3/4		628

RS3305A/9	9 Pieces Set/Rail 200mm	(g)
1/4, 5/16, 3/8, 7/16, 1/2, 9/16, 5/8, 11/16, 3/4		628

3300M / 3300A

6-point Deep Sockets
6-kant-Steckschlüssel,lang
Douilles longues 6-pans

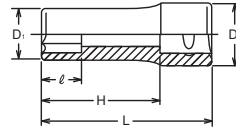

3305M / 3305A

12-point Deep Sockets
12-kant Steckschlüssel,lang
Douilles longues, 12-pans

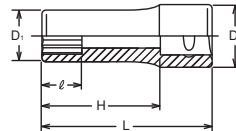

RS3300M/12

Socket Set on Rail
Steckschlüsselsatz auf Schiene
Jeu de douilles sur rail

RS3305M/12



RS3300A/9

Socket Set on Rail
Steckschlüsselsatz auf Schiene
Jeu de douilles sur rail

RS3305A/9



Z-SERIES
HAND
TITANIUM
ACCESSORIES
SCREWDRIVERS
IMPACT
SLEEVE-DRIVE
PROTECTOR
INDUSTRIAL
AUTOMOTIVE
MOTORCYCLE
CONSTRUCTION
SPARE PART

3300M (L120)

6-point Extra Deep Sockets
6-kant Steckschlüssel, extra lang
Douilles extra longues 6-pans



3305M (L120)

12-point Extra Deep Sockets
12-kant Steckschlüssel, extra lang
Douilles extra longues 12-pans

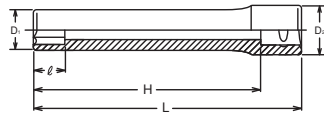

3300M/4-L120 3305M/4-L120

Socket Set
Steckschlüssel Satz
Jeu de clés à douille



3310M

Surface Drive Deep Sockets
Surface Drive Steckschlüssel, lang
Douilles longues, Surface Drive

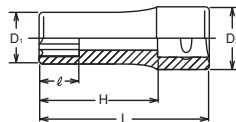

RS3310M/12

Socket Set on Rail
Steckschlüsselsatz auf Schiene
Jeu de douilles sur rail



3300M(L120) 3305M(L120) (mm)	D ₁ (mm)	D ₂ (mm)	ℓ (mm)	H (mm)	L (mm)	(g)	(pcs.)
8	12	17.3	9	106.5	120	85	10
10	14.5	17.3	11	106.5	120	110	10
12	16.8	17.2	13	106.5	120	116	10
13	18	17	14	106.5	120	155	5
14	20	18	16	106.5	120	166	5

3300M-Size DEEP SOCKET

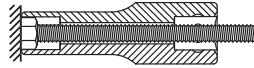

3300M-Size (L120) EXTRA DEEP SOCKET

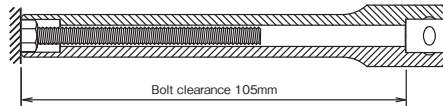

3300M/4-L120	4 Pieces Set/△=477g
PLASTIC BAG	
Sockets	
3300M(L120) 6-point Extra Deep Sockets 8, 10, 12, 14	

3305M/4-L120	4 Pieces Set/△=477g
PLASTIC BAG	
Sockets	
3305M(L120) 12-point Extra Deep Sockets 8, 10, 12, 14	

3310M (mm)	D ₁ (mm)	D ₂ (mm)	ℓ (mm)	H (mm)	L (mm)	(g)	(pcs.)
6	9.9	17.3	7	41.5	55	37	10
7	10.6	17.3	8	41.5	55	37	10
8	12	17.3	9	41.5	55	40	10
9	13	17.3	10	41.5	55	42	10
10	14.5	17.3	11	41.5	55	46	10
11	16	17.2	12	41.5	55	51	10
12	16.8	17.2	13	41.5	55	52	10
13	18	17	14	41.5	55	53	10
14	20	18	16	41.5	55	60	10
15	21	20	16	40.5	55	74	10
16	22	20	17	40.5	55	76	10
17	23.5	22	18	40.5	55	93	10
18	24.5	23	19	39.5	55	98	10
19	25	24	20	39.5	55	98	10
20	26	25	21	49.5	65	126	10
21	27	26	22	49.5	65	126	10
22	29	28	23	48.5	65	163	10
23	30	29	24	48.5	65	168	10
24	31	30	25	47.5	65	161	10

RS3310M/12	12 Pieces Set/Rail 300mm	(g)
8, 9, 10, 11, 12, 13, 14, 15, 16, 17, 18, 19		881

3300W 3305W (W)	D ₁ (mm)	D ₂ (mm)	ℓ (mm)	H (mm)	L (mm)	(g)	(pcs.)
1/8	12.3	17.3	10	41.5	55	46	10
3/16	16	17.3	12	41.5	55	55	10
1/4	18	17	14	41.5	55	57	10
5/16	21	20	16	40.5	55	79	10
3/8	24.5	23	19	39.5	55	96	10
7/16	27	26	22	49.5	65	140	10
1/2	30	29	24	48.5	65	193	10
9/16	34	31	27	47.5	65	250	10

3300W  6-point Deep Whitworth Sockets
6-kant Steckschlüssel, lang, Whitworth
Douilles longues à 6-pans Whitworth

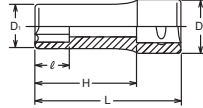

3305W  12-point Deep Whitworth Sockets
12-kant Steckschlüssel, Whitworth
Douilles longues à 12-pans Whitworth

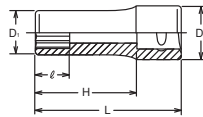

BS W



BS · W	BS	3/16BS	1/4BS	5/16BS	3/8BS	7/16BS	1/2BS	9/16BS	5/8BS	11/16BS	3/4BS	7/8BS
	W	1/8W	3/16W	1/4W	5/16W	3/8W	7/16W	1/2W	9/16W	5/8W	11/16W	3/4W
Across Flat	(ref. mm)	8.6	11.3	13.3	15.2	18.0	20.8	23.4	25.7	27.9	30.5	33.0

RS3300W/7	7 Pieces Set/Rail 200mm	(g)
1/8, 3/16, 1/4, 5/16, 3/8, 7/16, 1/2		719

RS3305W/7	7 Pieces Set/Rail 200mm	(g)
1/8, 3/16, 1/4, 5/16, 3/8, 7/16, 1/2		719

RS3300W/7   Socket Set on Rail
Steckschlüsselsatz auf Schiene
Jeu de douilles sur rail

RS3305W/7   Socket Set on Rail
Steckschlüsselsatz auf Schiene
Jeu de douilles sur rail



3325 (E)	D ₁ (mm)	D ₂ (mm)	ℓ (mm)	H (mm)	L (mm)	(g)	(pcs.)
E 4	5.6	17.3	4.6	41.5	55	29	10
E 5	6.9	17.3	5.2	41.5	55	31	10
E 6	7.9	17.3	5.4	41.5	55	33	10
E 7	8.9	17.3	6.6	41.5	55	36	10
E 8	9.9	17.3	7	41.5	55	39	10
E10	11.8	17.3	8.2	41.5	55	43	10
E12	14.5	17.2	9.3	41.5	55	53	10
E14	15.7	17.2	10.6	41.5	55	57	10
E16	18	17	11.8	41.5	55	69	10

3325  TORX® Deep Sockets
TORX® Steckschlüssel, lang
Douilles longues TORX®

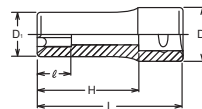

RS3325/9	9 Pieces Set/Rail 200mm	(g)
E4, E5, E6, E7, E8, E10, E12, E14, E16		420

RS3325/9   Socket Set on Rail
Steckschlüsselsatz auf Schiene
Jeu de douilles sur rail



Z-SERIES
HAND
TITANIUM
SCREWDRIVERS
ACCESSORIES
IMPACT
SLEEVE-DRIVE
PROTECTOR
INDUSTRIAL
AUTOMOTIVE
MOTORCYCLE
CONSTRUCTION
SPARE PART

3350M

 Nut Grip Deep Sockets **Nut Grip®**
Steckschlüssel mit 2-facher Kugelhalterung, lang
Douilles longues à billes de retenue



3350M (mm)	D ₁ (mm)	D ₂ (mm)	ℓ (mm)	H (mm)	L (mm)	(g)	(pcs.)
8	12	17.4	5	41.5	55	50	10
10	14.5	17.4	6	41.5	55	54	10
12	16.8	17.2	7	41.5	55	58	10
13	18	17	8	41.5	55	59	10
14	19.5	18.5	8.5	41.5	55	71	10

RS3350M/5

 Socket Set on Rail
Steckschlüsselsatz auf Schiene
Jeu de douilles sur rail



RS3350M/5	5 Pieces set/Rail 150mm	(g)
8, 10, 12, 13, 14		322

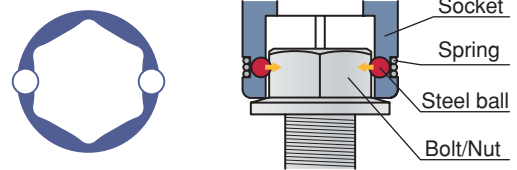

3350M (L120)

 Nut Grip Deep Sockets **Nut Grip®**
Steckschlüssel mit 2-facher Kugelhalterung, lang
Douilles à billes de retenue



3350M(L120) (mm)	D ₁ (mm)	D ₂ (mm)	ℓ (mm)	H (mm)	L (mm)	(g)	(pcs.)
10	14.5	17.2	6	106.5	120	110	10
12	16.8	17.2	7	106.5	120	116	10

3350M/2-L120

 Socket Set
Geschlitzte Steckschlüssel Satz
Jeu de clés à douille

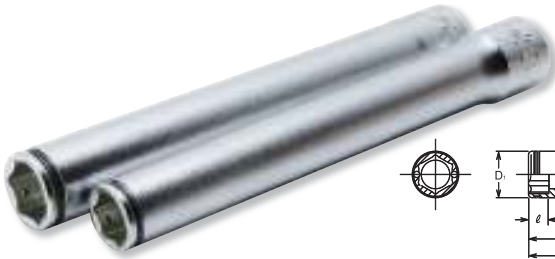

3350M/2-L120	2 Pieces Set/△=230g
PLASTIC BAG	
Sockets	
 3350M(L120) Nut Grip Extra Deep Sockets	10, 12

3300FN

 Flare Nut Sockets
Geschlitzte Steckschlüssel für Überwurfmuttern
Douilles à tuyauter

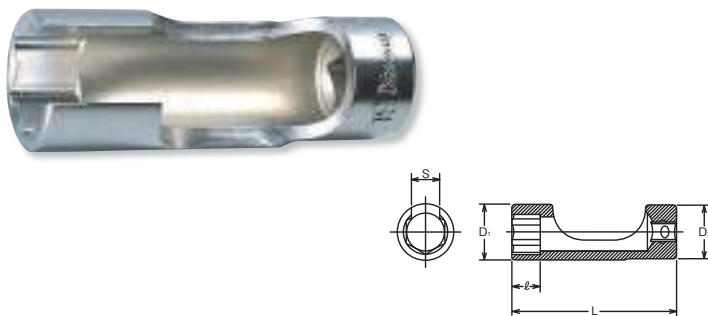

3300FN (mm)	D ₁ (mm)	D ₂ (mm)	ℓ (mm)	L (mm)	S (mm)	(g)	(pcs.)
8	14.5	17.3	6	53	6.4	38	10
9	16	17.3	7	53	6.8	41	10
10	16.8	17.2	7.5	53	7.2	42	10
11	18	17	8.5	53	8.3	42	10
12	20	18	9	53	8.8	50	10
13	21.1	20	9.5	62	9.4	66	10
14	22	20	10.5	62	10.5	66	10
15	23	22	11	70	11.5	82	10
16	24	23	11.5	70	12	90	10
17	25	24	12.5	80	13	110	10
18	27	25	13	80	13.5	120	10
19	28	26	14	80	14.5	130	10
22	32	29.5	16	80	16	180	10
24	34.5	31.5	17	80	17	200	10

RS3300FN/8

 Socket Set on Rail
Steckschlüsselsatz auf Schiene
Jeu de douilles sur rail



RS3300FN/8	8 Pieces Set/Rail 200mm	(g)
9, 10, 11, 13, 14, 16, 17, 19		600

3440M 3445M (mm)	D ₁ (mm)	D ₂ (mm)	ℓ (mm)	L (mm)	(g)	(pcs.)
8	12	19	7.3	47	50	10
9	13.3	19	7.8	47.5	50	10
10	14.5	19	8.8	48.5	64	10
11	15.8	19	9.8	49.5	66	10
12	17	19	10.3	50	67	10
13	18.3	19	11.3	51	68	10
14	19.5	19	11.3	51	69	10
15	20.8	19	12.8	53.5	70	10
16	22	19	12.8	53.5	77	10
17	23.3	19	13.8	54.5	80	10
18	24.5	19	13.8	54.5	80	10
19	25.8	19	15.8	56.5	84	10
21	28.3	19	16.8	56.5	96	10

3440M / 3440A

6-point Universal Sockets
6-kant Gelenk-Einsätze
Douilles articulées, 6-pans

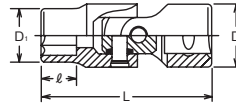

3440A 3445A (inch)	D ₁ (mm)	D ₂ (mm)	ℓ (mm)	L (mm)	(g)	(pcs.)
5/16	12	19	7.3	47	50	10
3/8	14	19	8.3	48	64	10
7/16	15.8	19	9.8	49.5	66	10
1/2	18.3	19	11.3	51	68	10
9/16	19.5	19	11.3	51	69	10
5/8	22	19	12.8	53.5	77	10
11/16	24.5	19	13.8	54.5	80	10
3/4	25.8	19	15.8	56.5	84	10

3445M / 3445A

12-point Universal Sockets
12-kant Gelenk-Einsätze
Douilles articulées, 12-pans

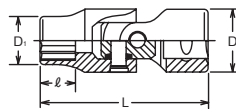

RS3440M/8	8 Pieces Set/Rail 200mm	(g)
8, 10, 11, 12, 13, 14, 17, 19		550

RS3440A/8	8 Pieces Set/Rail 200mm	(g)
5/16, 3/8, 7/16, 1/2, 9/16, 5/8, 11/16, 3/4		570

RS3440M/8 RS3440A/8

Socket Set on Rail
Steckschlüsselsatz auf Schiene
Jeu de douilles sur rail



3445W (W)	D ₁ (mm)	D ₂ (mm)	ℓ (mm)	L (mm)	(g)	(pcs.)
1/8	13.3	19	7.8	47.5	50	10
3/16	15.8	19	9.7	49.5	66	10
1/4	18.3	19	11.3	51	68	10
5/16	20.8	19	12.8	53.5	70	10
3/8	24.5	19	13.8	54.5	80	10
7/16	28.3	19	16.8	57.5	96	10
1/2	30.8	19	17.8	58.5	105	10

3445W

12-Point Whitworth Universal Socket
12-kant Gelenk-Einsatz, Whitworth
Douille articulées, 12-pans, Whitworth

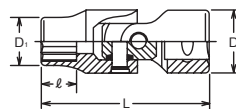

RS3445W/7	7 Pieces Set/Rail 200mm	(g)
1/8, 3/16, 1/4, 5/16, 3/8, 7/16, 1/2		570

RS3445W/7

Socket Set on Rail
Steckschlüsselsatz auf Schiene
Jeu de douilles sur rail



Z-SERIES
HAND
TITANIUM
ACCESSORIES
SCREWDRIVERS
IMPACT
SLEEVE-DRIVE
PROTECTOR
INDUSTRIAL
AUTOMOTIVE
MOTORCYCLE
CONSTRUCTION
SPARE PART

3440T

TORX® Universal Sockets
TORX® Gelenk-Einsätze
Douilles articulées TORX®

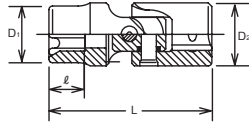

3440T (E)	D ₁ (mm)	D ₂ (mm)	ℓ (mm)	L (mm)	(g)	(pcs.)
E 6	7.9	19	5.4	44.9	60	10
E 8	9.9	19	7	46.5	63	10
E10	11.8	19	8.2	47.7	63	10
E12	14.5	19	9.3	48.8	68	10
E14	15.7	19	10.6	50.1	68	10
E16	18	19	11.8	51.3	70	10
E18	19.5	19	13	53.5	78	10
E20	22	19	14.4	54.9	81	10

RS3440T/8

Socket Set on Rail
Steckschlüsselsatz auf Schiene
Jeu de douilles sur rail



RS3440T/8	8 Pieces Set/Rail 200mm	(g)
E6, E8, E10, E12, E14, E16, E18, E20		594

3441M

Nut Grip Universal Sockets **Nut Grip®**
Gelenk-Einsätze mit zweifacher Kugelhalterung
Douilles articulées, à billes de retenue

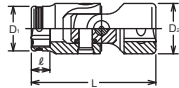

3441M (mm)	D ₁ (mm)	D ₂ (mm)	ℓ (mm)	L (mm)	(g)	(pcs.)
8	12	19	5	46	57	10
10	14.5	19	6	46	58	10
12	16.8	19	7	47	58	10
13	18	19	8	48	60	10
14	19.5	19	8.5	49.5	65	10



RS3441M/5

Socket Set on Rail
Steckschlüsselsatz auf Schiene
Jeu de douilles sur rail



RS3441M/5	5 Pieces Set/Rail 150mm	(g)
8, 10, 12, 13, 14		320

3340M-75

Universal Deep Sockets
Gelenk-Steckschlüssel, lange Ausführung
Douilles articulées longues

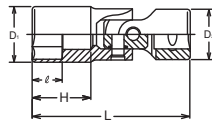

3340M-75 (mm)	D ₁ (mm)	D ₂ (mm)	ℓ (mm)	H (mm)	L (mm)	(g)	(pcs.)
8	12	19	9	39	75	82	10
10	14.5	19	11	39	75	87	10
11	15.8	19	12	39	75	87	10
12	17	19	13	39	75	92	10
13	18.3	19	14	36	75	93	10
14	19.5	19	15	35	75	103	10
15	20.8	19	16	35	75	104	10
16	22	19	17	34	75	110	10
17	23.3	19	18	34	75	115	10
18	24.5	19	19	34	75	119	10
19	25.8	19	20	33	75	123	10

RS3340M/8-L75

Socket Set on Rail
Steckschlüsselsatz auf Schiene
Jeu de douilles sur rail



RS3340M/8-L75	8 Pieces Set/Rail 200mm	(g)
8, 10, 11, 12, 13, 14, 17, 19		810

3/8" Hand Sockets Hand Steckschlüssel Douilles à main

3430M (mm)	D (mm)	ℓ (mm)	L (mm)	(g)	(pcs.)
5	19	15.5	62	66	10
6	19	15.5	62	70	10
7	19	15.5	62	72	10
8	19	15.5	62	74	10
10	19	15.5	62	78	10
12	19	15.5	62	85	10

3430M



Universal Hex Sockets
Gelenk-Einsätze für Schrauben mit Innensechskant
Douilles articulées, 6-pans mâle

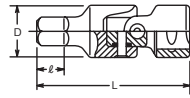

RS3430M/6	6 Pieces Set/Rail 150mm	(g)
	5, 6, 7, 8, 10, 12	470

RS3430M/6



Socket Set on Rail
Steckschlüsselsatz auf Schiene
Jeu de douilles sur rail



3117M-125/-250



Extended Sockets
Schaftsteckschlüssel
Douilles rallongées

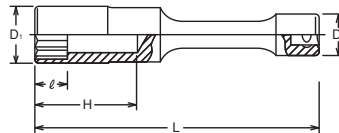

3117M-125 (mm)	D ₁ (mm)	D ₂ (mm)	ℓ (mm)	H (mm)	L (mm)	(g)	(pce.)
10	14.5	18	10	44	125	121	1
11	16	18	11	44	125	133	1
12	17	18	12	44	125	133	1
13	18	18	13	44	125	134	1
14	19.5	18	14	44	125	145	1
17	23.5	18	17	44	125	178	1
19	25	18	19	44	125	187	1
21	27	18	21	44	125	195	1
22	29	18	22	44	125	214	1

3117M-250 (mm)	D ₁ (mm)	D ₂ (mm)	ℓ (mm)	H (mm)	L (mm)	(g)	(pce.)
10	14.5	18	10	44	250	233	1
11	16	18	11	44	250	241	1
12	17	18	12	44	250	246	1
13	18	18	13	44	250	249	1
14	19.5	18	14	44	250	262	1
17	23.5	18	17	44	250	289	1
19	25	18	19	44	250	298	1
21	27	18	21	44	250	302	1
22	29	18	22	44	250	325	1



Z-SERIES
HAND
TITANIUM
ACCESSORIES
SCREWDRIVERS
IMPACT
SLEEVE-DRIVE
PROTECTOR
INDUSTRIAL
AUTOMOTIVE
MOTORCYCLE
CONSTRUCTION
SPARE PART

Z-SERIES
HAND
TITANIUM
SCREWDRIVERS ACCESSORIES
IMPACT
SLEEVE-DRIVE
PROTECTOR
INDUSTRIAL
AUTOMOTIVE
MOTORCYCLE
CONSTRUCTION
SPARE PART

3000-60 (PH)

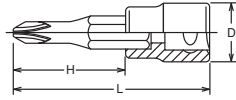
 Phillips Bit Sockets
Steckschlüssel für Kreuzschlitzschrauben, Phillips
Douilles tournevis pour vis à empreinte Phillips





3000 (PH)	D (mm)	H (mm)	L (mm)	 (g)	 (pcs.)
1	18	33.5	60	49	10
2	18	33.5	60	49	10
3	18	33.5	60	49	10
4	18	33.5	60	50	10

3000-50 (PZ)

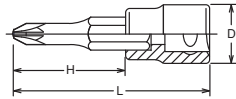
 PZ Bit Sockets
Steckschlüssel für Kreuzschlitzschrauben, PZ
Douilles tournevis pour vis à empreinte PZ









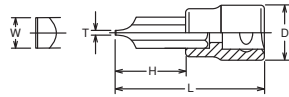









3000-50 (PZ)	D (mm)	H (mm)	L (mm)	 (g)	 (pcs.)
PZ1	18	23.5	50	50	10
PZ2	18	23.5	50	50	10
PZ3	18	23.5	50	50	10

3005-60



 Bit Sockets for Slotted Heads
Steckschlüssel für Schlitzschrauben
Douilles tournevis pour vis à fente



3005	T×W (mm)	D (mm)	H (mm)	L (mm)	 (g)	 (pcs.)
5	1.0× 5.5	18	33.5	60	47	10
8	1.2× 8	18	33.5	60	49	10
10	1.6×10	20	33.5	60	85	10

	 Phillips (PH)	 PZ	 Slotted	 HEX	 HEX (ball point)	 Triple Square (XZN)	 TORX® (T)	 TORX® (TH)	 TORXPLUS® (IP)	 TORXPLUS® (IPR)	 Ribe-CV
	No.2000 series	No.2000(PZ) series	No.2005 series	No.2010M/A series	No.2011M series	No.2020 series	No.2025 series	No.2025(TH) series	No.2025(IP) series	No.2025(IPR) series	—
	No.3000 No.3001 series	No.3000(PZ) series	No.3005 No.3006 series	No.3010M/A No.3012M/A No.3015M series	No.3011M series	No.3020 series	No.3025 series	No.3025(TH) series	No.3025(IP) series	No.3025(IPR) series	No.3027 series
	No.4000 No.4001 series	No.4000(PZ) series	No.4005 No.4006 series	No.4010M/A No.4012M/A series	—	No.4020 series	No.4025 series	—	No.4025(IP) series	—	No.4027 series

3010M-38/-62/-100/-160 3010A-50

 Inhex Bit Sockets
Steckschlüssel für Innensechskant-Schrauben
 Douilles tournevis pour vis 6-pans creux

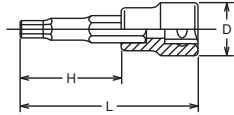

3010M-38 (mm)	D (mm)	H (mm)	L (mm)	(g)	(pcs.)
3	18	11.5	38	27	10
4	18	11.5	38	28	10
5	18	11.5	38	30	10
6	18	11.5	38	31	10
7	18	11.5	38	32	10
8	18	11.5	38	33	10
9	20	11.5	38	47	10
10	20	11.5	38	48	10
11	20	11.5	38	59	10
12	20	11.5	38	60	10
13	22	11.5	38	76	5
14	22	11.5	38	78	5

3010M-62 (mm)	D (mm)	H (mm)	L (mm)	(g)	(pcs.)
3	18	35.5	62	43	10
4	18	35.5	62	45	10
5	18	35.5	62	48	10
6	18	35.5	62	49	10
7	18	35.5	62	50	10
8	18	35.5	62	62	10
9	20	35.5	62	75	10
10	20	35.5	62	76	10
11	20	35.5	62	92	10
12	20	35.5	62	94	10
13	22	35.5	62	107	5
14	22	35.5	62	109	5

3010M-100 (mm)	D (mm)	H (mm)	L (mm)	(g)	(pcs.)
3	18	73.5	100	58	10
4	18	73.5	100	60	10
5	18	73.5	100	63	10
6	18	73.5	100	64	10
7	18	73.5	100	66	10
8	18	73.5	100	69	10
9	20	73.5	100	100	10
10	20	73.5	100	102	10
11	20	73.5	100	129	10
12	20	73.5	100	131	10
13	22	73.5	100	158	5
14	22	73.5	100	160	5

3010M-160 (mm)	D (mm)	H (mm)	L (mm)	(g)	(pcs.)
3	18	133.5	160	84	10
4	18	133.5	160	86	10
5	18	133.5	160	89	10
6	18	133.5	160	90	10
7	18	133.5	160	92	10
8	18	133.5	160	95	10
9	20	133.5	160	125	10
10	20	133.5	160	128	10
11	20	133.5	160	153	10
12	20	133.5	160	157	10
13	22	133.5	160	237	5
14	22	133.5	160	239	5

3010A-50 (inch)	D (mm)	H (mm)	L (mm)	(g)	(pcs.)
1/8	18	23.5	50	35	10
5/32	18	23.5	50	36	10
3/16	18	23.5	50	36	10
7/32	18	23.5	50	38	10
1/4	18	23.5	50	40	10
9/32	18	23.5	50	42	10
5/16	18	23.5	50	44	10
11/32	20	23.5	50	59	10
3/8	20	23.5	50	60	10
7/16	20	23.5	50	74	10
1/2	22	23.5	50	91	5

RS3010M/8-L38	8 Pieces Set/Rail 200mm	(g)
3, 4, 5, 6, 7, 8, 10, 12		322
RS3010M/8-L62	8 Pieces Set/Rail 200mm	(g)
3, 4, 5, 6, 7, 8, 10, 12		490
RS3010M/8-L100	8 Pieces Set/Rail 200mm	(g)
3, 4, 5, 6, 7, 8, 10, 12		645
RS3010A/8-L50	8 Pieces Set/Rail 200mm	(g)
1/8, 5/32, 3/16, 7/32, 1/4, 5/16, 3/8, 1/2		400

RS3010M/8-L38



Socket Set on Rail
Steckschlüsselsatz auf Schiene
Jeu de douilles sur rail

RS3010M/8-L62



RS3010M/8-L100



RS3010A/8-L50



Z-SERIES
HAND
TITANIUM
ACCESSORIES
SCREWDRIVERS
IMPACT
SLEEVE-DRIVE
PROTECTOR
INDUSTRIAL
AUTOMOTIVE
MOTORCYCLE
CONSTRUCTION
SPARE PART

3012M-25



Inhex Sockets
Steckschlüssel für Innensechskant-Schrauben
Douilles tournevis pour vis 6-pans creux

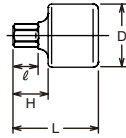

3012M-25 (inch)	D (mm)	ℓ (mm)	H (mm)	L (mm)	(g)	(pcs.)
New 3	18.5	5.5	10	25	22	10
New 4	18.5	5.5	10	25	22	10
New 5	18.5	6.5	10	25	22	10
New 6	18.5	7.5	10	25	23	10
New 7	18.5	10	-	25	24	10
New 8	18.5	10	-	25	25	10
New 10	18.5	10	-	25	27	10
New 12	18.5	10	-	25	30	10
New 14	19	10	-	25	30	10
New 17	19	10	-	25	30	10

For Lubrication Service
Schmierdienst-Werkzeuge
Service lubrification-vidange

3012M-52/-62/-75



Inhex Sockets
Steckschlüssel für Innensechskant-Schrauben



3012A -52/-62/-75



Douilles tournevis pour vis 6-pans creux

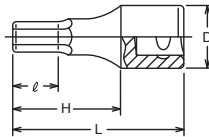

3012M/A are for hand use only.
Do not use with a power or impact wrench.
Bitte nicht auf Schlagschrauber oder anderen
Maschinen gebrauchen.
A ne pas utiliser sur des machines

3012M-52 (mm)	D (mm)	ℓ (mm)	H (mm)	L (mm)	(g)	(pcs.)
3	18	10	34	52	35	10
4	18	15.5	34	52	38	10
5	18	15.5	34	52	40	10
6	18	15.5	34	52	42	10
7	18	15.5	34	52	46	10
8	18.5	15.5	34	52	50	10
9	18.5	15.5	34	52	55	10
10	20	15.5	34	52	66	10
11	20	15.5	34	52	72	10
12	20	15.5	34	52	77	10
13	20	15.5	34	52	82	10
14	20	15.5	34	52	89	10

3012A-52 (inch)	D (mm)	ℓ (mm)	H (mm)	L (mm)	(g)	(pcs.)
1/8	18	10	34	52	35	10
5/32	18	15.5	34	52	38	10
3/16	18	15.5	34	52	40	10
7/32	18	15.5	34	52	42	10
1/4	18	15.5	34	52	44	10
9/32	18	15.5	34	52	46	10
5/16	18.5	15.5	34	52	50	10
11/32	18.5	15.5	34	52	55	10
3/8	20	15.5	34	52	65	10
7/16	20	15.5	34	52	72	10
1/2	20	15.5	34	52	82	10
9/16	20	15.5	34	52	89	10

3012M-62 (mm)	D (mm)	ℓ (mm)	H (mm)	L (mm)	(g)	(pcs.)
3	18	10	44	62	38	10
4	18	15.5	44	62	40	10
5	18	15.5	44	62	43	10
6	18	15.5	44	62	46	10
7	18	15.5	44	62	53	10
8	18.5	15.5	44	62	58	10
9	18.5	15.5	44	62	63	10
10	20	15.5	44	62	77	10
11	20	15.5	44	62	83	10
12	20	15.5	44	62	90	10
13	20	15.5	44	62	95	10
14	20	15.5	44	62	109	10

3012A-62 (inch)	D (mm)	ℓ (mm)	H (mm)	L (mm)	(g)	(pcs.)
1/8	18	10	44	62	38	10
5/32	18	15.5	44	62	40	10
3/16	18	15.5	44	62	43	10
7/32	18	15.5	44	62	46	10
1/4	18	15.5	44	62	48	10
9/32	18	15.5	44	62	53	10
5/16	18.5	15.5	44	62	58	10
11/32	18.5	15.5	44	62	63	10
3/8	20	15.5	44	62	73	10
7/16	20	15.5	44	62	83	10
1/2	20	15.5	44	62	95	10
9/16	20	15.5	44	62	109	10

3012M-75 (mm)	D (mm)	ℓ (mm)	H (mm)	L (mm)	(g)	(pcs.)
3	18	10	57	75	41	10
4	18	15.5	57	75	43	10
5	18	15.5	57	75	48	10
6	18	15.5	57	75	53	10
7	18	15.5	57	75	58	10
8	18.5	15.5	57	75	72	10
9	18.5	15.5	57	75	92	10
10	20	15.5	57	75	114	10
11	20	15.5	57	75	120	10
12	20	15.5	57	75	127	10
13	20	15.5	57	75	132	10
14	20	15.5	57	75	146	10

3012A-75 (inch)	D (mm)	ℓ (mm)	H (mm)	L (mm)	(g)	(pcs.)
1/8	18	10	57	75	41	10
5/32	18	15.5	57	75	43	10
3/16	18	15.5	57	75	48	10
7/32	18	15.5	57	75	53	10
1/4	18	15.5	57	75	53	10
9/32	18	15.5	57	75	58	10
5/16	18.5	15.5	57	75	72	10
11/32	18.5	15.5	57	75	92	10
3/8	20	15.5	57	75	110	10
7/16	20	15.5	57	75	120	10
1/2	20	15.5	57	75	132	10
9/16	20	15.5	57	75	146	10

3011M-62 (mm)	D (mm)	H (mm)	L (mm)	(g)	(pcs.)
3	18	35.5	62	45	10
4	18	35.5	62	46	10
5	18	35.5	62	48	10
6	18	35.5	62	49	10
7	18	35.5	62	50	10
8	18	35.5	62	51	10
10	20	35.5	62	66	10
12	20	35.5	62	79	10

3011M-100 (mm)	D (mm)	H (mm)	L (mm)	(g)	(pcs.)
3	18	73.5	100	61	10
4	18	73.5	100	62	10
5	18	73.5	100	64	10
6	18	73.5	100	65	10
7	18	73.5	100	67	10
8	18	73.5	100	68	10

3011M-120 (mm)	D (mm)	H (mm)	L (mm)	(g)	(pcs.)
3	18	93.5	120	77	10
4	18	93.5	120	78	10
5	18	93.5	120	80	10
6	18	93.5	120	81	10
7	18	93.5	120	83	10
8	18	93.5	120	84	10

3011M-160 (mm)	D (mm)	H (mm)	L (mm)	(g)	(pcs.)
3	18	133.5	160	87	10
4	18	133.5	160	88	10
5	18	133.5	160	89	10
6	18	133.5	160	91	10
7	18	133.5	160	93	10
8	18	133.5	160	95	10

⚠ Ball point bit sockets have less strength due to the special design. Make sure to use them correctly.

3015M-62 (mm)	D (mm)	H (mm)	L (mm)	(g)	(pcs.)
3	18	35.5	62	43	10
4	18	35.5	62	45	10
5	18	35.5	62	50	10
6	18	35.5	62	50	10
7	18	35.5	62	50	10
8	18	35.5	62	62	10
10	20	35.5	62	75	10
12	20	35.5	62	95	10

3015M-100 (mm)	D (mm)	H (mm)	L (mm)	(g)	(pcs.)
3	18	73.5	100	60	10
4	18	73.5	100	60	10
5	18	73.5	100	65	10
6	18	73.5	100	65	10
7	18	73.5	100	70	10
8	18	73.5	100	70	10
10	20	73.5	100	105	10
12	20	73.5	100	135	10

Grip Ring holds hex screws

⚠ Grip Ring bit sockets have less strength due to the special design. Make sure to use them correctly.

RS3015M/8-L62	8 Pieces Set/Rail 200mm	(g)
3, 4, 5, 6, 7, 8, 10, 12		500

RS3015M/8-L100	8 Pieces Set/Rail 200mm	(g)
3, 4, 5, 6, 7, 8, 10, 12		650

3011M-62/-100/-120/-160

⚠ Ballpoint Inhex Sockets
Steckschlüssel mit Kugelkopf, für Innensechskant-Schrauben
Douilles tournevis avec tête sphérique pour vis 6-pans creux

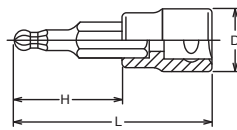

3015M-62/-100

⚠ Inhex Bit Socket, Grip Ring
Steckschlüssel für Innensechskant-Schrauben
Douilles tournevis pour vis 6-pans creux

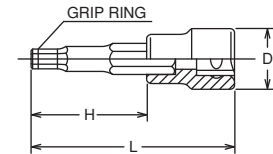

RS3015M/8-L62

RS3015M/8-L100

⚠ Socket Set on Rail
Steckschlüsselsatz auf Schiene
Jeu de douilles sur rail



3020-38/-50/-100/-120



XZN Bit Sockets
Steckschlüssel für XZN Schrauben
Douilles tournevis pour empreinte XZN

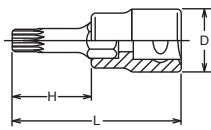

3020-38 (XZN)	D (mm)	H (mm)	L (mm)	(g)	(pcs.)
M 5	18	11.5	38	32	10
M 6	18	11.5	38	33	10
M 8	18	11.5	38	36	10
M10	20	11.5	38	51	10
M12	20	11.5	38	52	10
M14	22	11.5	38	74	10

3020-50 (XZN)	D (mm)	H (mm)	L (mm)	(g)	(pcs.)
M 4	18	23.5	50	35	10
M 5	18	23.5	50	37	10
M 6	18	23.5	50	39	10
M 8	18	23.5	50	40	10
M10	20	23.5	50	65	10
M12	20	23.5	50	69	10
M14	22	23.5	50	75	10

3020-100 (XZN)	D (mm)	H (mm)	L (mm)	(g)	(pcs.)
M 4	18	73.5	100	57	10
M 5	18	73.5	100	59	10
M 6	18	73.5	100	61	10
M 8	18	73.5	100	62	10
M10	20	73.5	100	99	10
M12	20	73.5	100	103	10
M14	22	73.5	100	145	5

3020-120 (XZN)	D (mm)	H (mm)	L (mm)	(g)	(pcs.)
M 4	18	93.5	120	77	10
M 5	18	93.5	120	79	10
M 6	18	93.5	120	81	10
M 8	18	93.5	120	82	10
M10	20	93.5	120	119	10
M12	20	93.5	120	123	10
M14	22	93.5	120	165	5

XZN

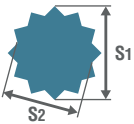

XZN		M4	M5	M6	M8	M10	M12	M14	M16	M18
S ₁	(ref. mm)	3.6	4.8	6.1	7.3	9.7	11.5	13.3	15.7	16.9
S ₂	(ref. mm)	3.1	4.1	5.1	6.1	8.1	9.7	11.2	13.2	14.2

RS3020/6-L38



Socket Set on Rail
Steckschlüsselsatz auf Schiene
Jeu de douilles sur rail



RS3020/6-L38 6 Pieces Set/Rail 150mm

M5, M6, M8, M10, M12, M14

(g)

308

RS3020/7-L50



Socket Set on Rail
Steckschlüsselsatz auf Schiene
Jeu de douilles sur rail



RS3020/7-L50 7 Pieces Set/Rail 200mm

M4, M5, M6, M8, M10, M12, M14

(g)

400

3/8"

Hand Sockets
Hand Steckschlüssel
Douilles à main

3025-38 (T)	D (mm)	H (mm)	L (mm)	(g)	(pcs.)
T 8	18	11.5	38	32	10
T 9	18	11.5	38	32	10
T10	18	11.5	38	32	10
T15	18	11.5	38	33	10
T20	18	11.5	38	33	10
T25	18	11.5	38	33	10
T27	18	11.5	38	33	10
T30	18	11.5	38	33	10
T40	18	11.5	38	34	10
T45	18	11.5	38	37	10
T50	20	11.5	38	49	10
T55	20	11.5	38	57	10

3025-50 (T)	D (mm)	H (mm)	L (mm)	(g)	(pcs.)
T 8	18	23.5	50	36	10
T 9	18	23.5	50	36	10
T10	18	23.5	50	36	10
T15	18	23.5	50	36	10
T20	18	23.5	50	36	10
T25	18	23.5	50	37	10
T27	18	23.5	50	37	10
T30	18	23.5	50	38	10
T40	18	23.5	50	39	10
T45	18	23.5	50	41	10
T50	20	23.5	50	55	10
T55	20	23.5	50	67	10

3025-38/-50/-140 (T)



TORX® Bit Sockets
TORX® Bit-Steckschlüssel
Douilles tournevis, TORX®

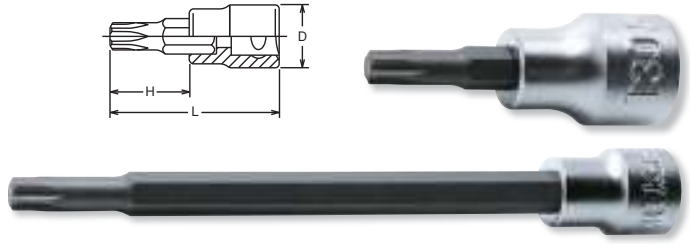

3025-140 (T)	D (mm)	H (mm)	L (mm)	(g)	(pcs.)
T 9	18	113.5	140	75	10
T10	18	113.5	140	75	10
T15	18	113.5	140	75	10
T20	18	113.5	140	75	10
T25	18	113.5	140	76	10
T27	18	113.5	140	76	10
T30	18	113.5	140	77	10
T40	18	113.5	140	78	10
T45	18	113.5	140	80	10
T50	20	113.5	140	94	10
T55	20	113.5	140	106	10

TORX® (T)

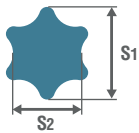

T	T8	T9	T10	T15	T20	T25	T27	T30	T40	T45	T50	T55	T60	T70	T80	T90	T100
S ₁ (ref. mm)	2.3	2.5	2.7	3.3	3.9	4.5	5.0	5.6	6.7	7.9	8.9	11.3	13.3	15.6	17.6	20.0	22.2
S ₂ (ref. mm)	1.7	1.8	2.0	2.3	2.8	3.2	3.6	4.0	4.8	5.6	6.2	8.0	9.5	11.1	12.7	14.2	15.8

RS3025/8-L38	8 Pieces Set/Rail 200mm	(g)
T10, T15, T20, T25, T27, T30, T40, T45		300

RS3025/8-L50	8 Pieces Set/Rail 200mm	(g)
T10, T15, T20, T25, T27, T30, T40, T45		320

3025-50 (T)	D (mm)	H (mm)	L (mm)	(g)	(pcs.)
T35	18	23.5	50	39	10

3025-100R (T)	D (mm)	H (mm)	L (mm)	(g)	(pcs.)
T20	18	73.5	100	38	10
T25	18	73.5	100	40	10
T27	18	73.5	100	42	10
T30	18	73.5	100	45	10
T40	18	73.5	100	52	10
T45	18	73.5	100	73	10
T50	20	73.5	100	80	10
T55	20	73.5	100	106	10

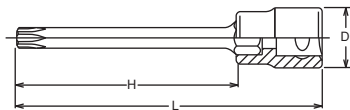

RS3025/8-L100R	8 Pieces Set/Rail 200mm	(g)
T20, T25, T27, T30, T40, T45, T50, T55		490

RS3025/8-L38/-L50 (T)



Socket Set on Rail
Steckschlüsselsatz auf Schiene
Jeu de douilles sur rail



3025-50-T35



Bit Socket
Bit-Steckschlüssel
Douilles tournevis



3025-100R (T)



TORX® Bit Sockets, round-shaft
TORX® Bit-Steckschlüssel mit Rundschaft
Douilles tournevis TORX® avec manche ronde



RS3025/8-L100R



Socket Set on Rail
Steckschlüsselsatz auf Schiene
Jeu de douilles sur rail



Z-SERIES
HAND
TITANIUM
SCREWDRIVERS ACCESSORIES
IMPACT
SLEEVE-DRIVE
PROTECTOR
INDUSTRIAL
AUTOMOTIVE
MOTORCYCLE
CONSTRUCTION
SPARE PART

3025-50/-160 (TH)

 Tamper Resistant TORX® Bit Sockets
Tamper Resistant TORX® Bit-Steckschlüssel
Douilles tournevis, Tamper-Resistant TORX®



 Tamper Resistant TORX® Bit Sockets have less strength due to special design. Make sure to use it correctly.



Bitte beachten Sie die geringere Belastbarkeit der Tamper Resistant Torx Steckschlüssel.

Veuillez respecter la moindre capacité inférieure de charge des douilles Tamper Resistant Torx.

3025-50 (TH)	D (mm)	H (mm)	L (mm)	(g)	(pcs.)
T10H	18	23.5	50	37	10
T15H	18	23.5	50	38	10
T20H	18	23.5	50	38	10
T25H	18	23.5	50	38	10
T27H	18	23.5	50	38	10
T30H	18	23.5	50	39	10
T40H	18	23.5	50	40	10
T45H	18	23.5	50	41	10
T50H	20	23.5	50	61	10
T55H	20	23.5	50	61	10

3025-160 (TH)	D (mm)	H (mm)	L (mm)	(g)	(pcs.)
T25H	18	133.5	160	83	10
T27H	18	133.5	160	83	10
T30H	18	133.5	160	84	10
T40H	18	133.5	160	85	10
T45H	18	133.5	160	86	10
T50H	20	133.5	160	128	10
T55H	20	133.5	160	128	10

RS3025/9-L50 (TH)

  Socket Set on Rail
Steckschlüsselsatz auf Schiene
Jeu de douilles sur rail



RS3025/9-HOLE	9 Pieces Set/Rail 200mm	(g)
T10H, T15H, T20H, T25H, T27H, T30H, T40H, T45H, T50H		405

3247

 Bit Socket Set
Schraubendreher-Steckschlüssel Satz
Jeu de douilles de vissage



3247	4 Pieces Set/ =385g
PLASTIC BAG	
Sockets	
 3025.160 Tamper-Resistant TORX® Bit Sockets	T27H, T30H, T40H, T50H

3025-100R (TH)



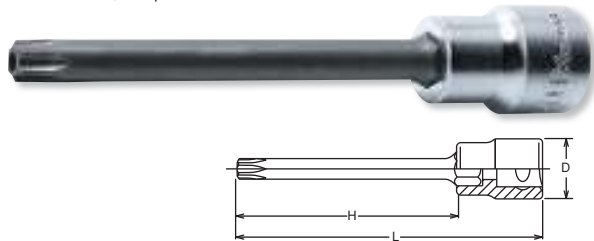

Tamper-Resistant TORX® Bit Sockets, round-shaft
Tamper-Resistant TORX® Bit-Steckschlüssel mit Rundschaft
Douilles tournevis, Tamper-Resistant TORX® avec manche ronde



3025-100R (TH)	D (mm)	H (mm)	L (mm)	(g)	(pcs.)
T20H	18	73.5	100	38	10
T25H	18	73.5	100	40	10
T27H	18	73.5	100	42	10
T30H	18	73.5	100	45	10
T40H	18	73.5	100	52	10
T45H	18	73.5	100	73	10
T50H	20	73.5	100	80	10
T55H	20	73.5	100	106	10

RS3025/8-L100RH

  Socket Set on Rail
Steckschlüsselsatz auf Schiene
Jeu de douilles sur rail



RS3025/8-L100RH	8 Pieces Set/Rail 200mm	(g)
T20H, T25H, T27H, T30H, T40H, T45H, T50H, T55H		490

3/8"

Hand Sockets
Hand Steckschlüssel
Douilles à main

3025-50 (IP)	D (mm)	H (mm)	L (mm)	(g)	(pcs.)
10IP	18	23.5	50	38	10
15IP	18	23.5	50	38	10
20IP	18	23.5	50	38	10
25IP	18	23.5	50	38	10
27IP	18	23.5	50	40	10
30IP	18	23.5	50	40	10
40IP	18	23.5	50	41	10
45IP	18	23.5	50	41	10
50IP	20	23.5	50	61	10
55IP	20	23.5	50	61	10

3025-50 (IP)

TORXPLUS® Bit Sockets
TORXPLUS® Bit-Steckschlüssel
Douilles tournevis, TORXPLUS®

TORXplus

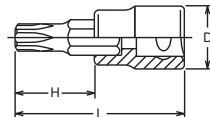

TORXPLUS® (IP)

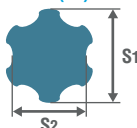

IP	8IP	9IP	10IP	15IP	20IP	25IP	27IP	30IP	40IP	45IP	50IP	55IP	60IP	70IP
S ₁ (ref. mm)	2.3	2.5	2.7	3.3	3.9	4.5	5.0	5.6	6.7	7.9	8.9	11.3	13.3	15.6
S ₂ (ref. mm)	1.7	1.8	2.0	2.3	2.8	3.2	3.6	4.0	4.8	5.6	6.2	8.0	9.5	11.1

RS3025/8-IP	8 Pieces Set/Rail 200mm	(g)
20IP, 25IP, 27IP, 30IP, 40IP, 45IP, 50IP, 55IP		370

RS3025/8 (IP)

Socket Set on Rail
Steckschlüsselsatz auf Schiene
Jeu de douilles sur rail



RSX025/11-IP	11 Pieces Set/Rail 200mm	(g)
2025.28(IP)	10IP, 15IP, 20IP, 25IP, 27IP	480
3025.50(IP)	30IP, 40IP, 45IP, 50IP	
4025.60(IP)	55IP, 60IP	

RSX025/11 (IP)

Socket Set on Rail
Steckschlüsselsatz auf Schiene
Jeu de douilles sur rail



1/4" + 3/8" + 1/2"

TORXplus®

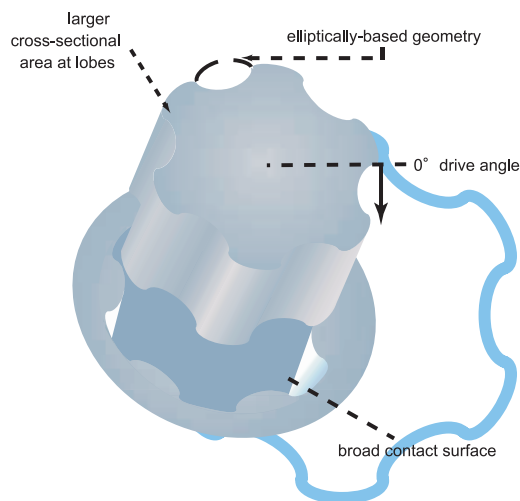
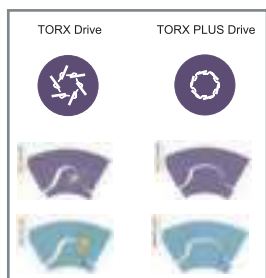
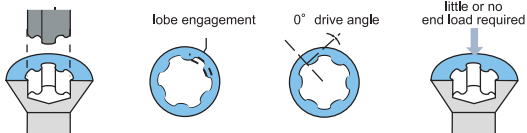

3025-50 (IPR)



TORXPLUS® Bit Sockets, with hole
TORXPLUS® Bit-Steckschlüssel mit Stirnbohrung
douilles tournevis TORXPLUS® avec trou

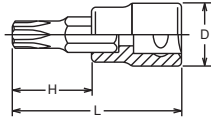

3025-50 (IPR)	D (mm)	H (mm)	L (mm)	(g)	(pcs.)
10IPR	18	23.5	50	38	10
15IPR	18	23.5	50	38	10
20IPR	18	23.5	50	38	10
25IPR	18	23.5	50	38	10
27IPR	18	23.5	50	40	10
30IPR	18	23.5	50	40	10
40IPR	18	23.5	50	41	10
45IPR	18	23.5	50	41	10
50IPR	20	23.5	50	61	10
55IPR	20	23.5	50	61	10

TORXPLUS® (IPR)

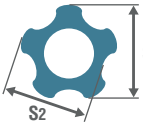

IPR	8IPR	9IPR	10IPR	15IPR	20IPR	25IPR	27IPR	30IPR	40IPR	45IPR	50IPR	55IPR
S ₁ (ref. mm)	2.2	2.4	2.6	3.1	3.6	4.1	4.7	5.2	6.3	7.4	8.4	10.6
S ₂ (ref. mm)	2.0	2.2	2.4	2.8	3.3	3.8	4.3	4.8	5.7	6.7	7.6	9.7

RS3025/9 (IPR)



Socket Set on Rail
Steckschlüsselsatz auf Schiene
Jeu de douilles sur rail



RS3025/9-IPR	9 Pieces Set/Rail 200mm	(g)
10IPR, 15IPR, 20IPR, 25IPR, 27IPR, 30IPR, 40IPR, 45IPR, 50IPR		395

RSX025/11 (IPR)



Socket Set on Rail
Steckschlüsselsatz auf Schiene
Jeu de douilles sur rail



RSX025/11-IPR	11 Pieces Set/Rail 200mm	(g)
2025.28(IPR)	8IPR, 10IPR, 15IPR, 20IPR, 25IPR, 27IPR, 30IPR	320
3025.50(IPR)	40IPR, 45IPR, 50IPR, 55IPR	

1/4" + 3/8"

3027-50/-100



Bit Sockets for Ribe Screws
Steckschlüsselklingen für Ribe Schrauben
Douilles tournevis pour écrous profil Ribe

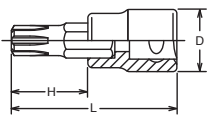

3027-50	D (mm)	H (mm)	L (mm)	(g)	(pcs.)
M 5	18	23.5	50	38	10
M 6	18	23.5	50	38	10
M 7	18	23.5	50	38	10
M 8	18	23.5	50	39	10
M 9	20	23.5	50	40	10
M10	20	23.5	50	40	10
M12	20	23.5	50	41	10

3027-100	D (mm)	H (mm)	L (mm)	(g)	(pcs.)
M 5	18	73.5	100	40	10
M 6	18	73.5	100	42	10
M 8	18	73.5	100	45	10
M10	20	73.5	100	52	10
M12	20	73.5	100	73	10

Ribe CV

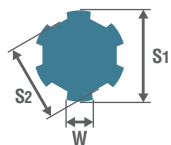

CV	M5	M6	M7	M8	M9	M10	M12	M13	M14	M16
W (ref. mm)	1.2	1.3	1.4	1.8	2.0	2.3	2.6	3.1	3.2	3.6
S ₁ (ref. mm)	5.0	6.0	7.0	8.0	9.0	10.0	12.0	13.0	14.0	16.0
S ₂ (ref. mm)	3.8	4.5	5.0	6.0	7.1	7.4	9.0	11.0	10.4	11.9

RS3027/5-L50



Socket Set on Rail
Steckschlüsselsatz auf Schiene
Jeu de douilles sur rail



RS3027/5-L50	5 Pieces Set/Rail 150mm	(g)
M5, M6, M8, M10, M12		240

3110M (mm)		D (mm)	ℓ (mm)	L (mm)	(g)	(pcs.)
6		18	10	28	30	10
8	3/8"	18	10	28	30	10
10		18	10	28	33	10
12		18	10	28	37	10

3110A (inch)		D (mm)	ℓ (mm)	L (mm)	(g)	(pcs.)
5/16	3/8"	18	10	28	30	10
3/8		18	10	28	33	10
1/2		18	10	28	37	10

		D ₁ (mm)	D ₂ (mm)	L (mm)	(g)	(pcs.)
3137	3/8"	13	16.5	30	30	10

For DIN3126 C6.3 Bits
Für DIN3126 C6.3 Bits
Pour DIN3126 C6.3 Embouts

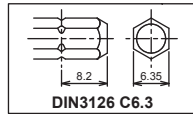

DIN3126 C6.3



		D ₁ (mm)	D ₂ (mm)	L (mm)	(g)	(pcs.)
3138	3/8"	16	18	38	55	10

For DIN3126 C8 Bits
Für DIN3126 C8 Bits
Pour DIN3126 C8 Embouts

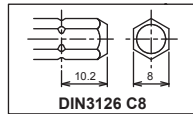

DIN3126 C8



		D ₁ (mm)	D ₂ (mm)	L (mm)	(g)	(pcs.)
3141	3/8"	16	18	48	60	10

3110M / 3110A

4-point Male Sockets
Öldienst-Steckschlüssel
Douilles mâles 4-pans

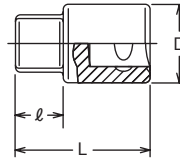

3137

Bit Holder
Klingenhalter
Porte-embouts

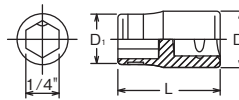

3138

Bit Holder
Klingenhalter
Porte-embouts

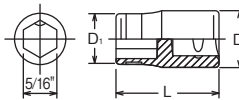

3141

Bit Holder, extra deep for 131P-80, 131S-80, 131T-80
Klingenhalter, extra tief für 131P-80, 131S-80, 131T-80
Porte-embouts, ouverture longue pour 131P-80, 131S-80, 131T-80

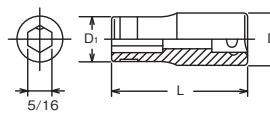

Z-SERIES
HAND
TITANIUM
SCREWDRIVERS ACCESSORIES
IMPACT
SLEEVE-DRIVE
PROTECTOR
INDUSTRIAL
AUTOMOTIVE
MOTORCYCLE
CONSTRUCTION
SPARE PART

2749PS-3/8 ⚠

Reversible Ratchet (Short)
Knarre kurz, verstellbar
Cliquet courte, réversible

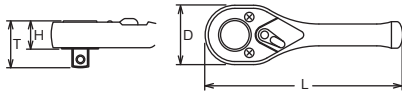

* Renewal Kits → 2749RK-3/8 → P298

	D (mm)	T (mm)	H (mm)	L (mm)	(g)	(pcs.)
2749PS-3/8	25	21.9	11.2	75	70	10

2749P-3/8 ⚠

Reversible Ratchet
Knarre, verstellbar
Cliquet, réversible

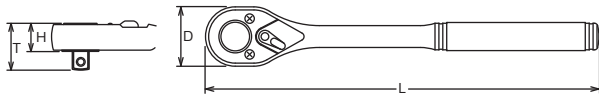

* Renewal Kits → 2749RK-3/8 → P298

	D (mm)	T (mm)	H (mm)	L (mm)	(g)	(pcs.)
2749P-3/8	25	21.9	11.2	125	101	10

⚠ 2749-3/8 series have less strength compared with normal 38 ratchet due to the technical design. Make sure to use the ratchet correctly.

3749S ⚠

Reversible Ratchet (Short)
Knarre kurz, verstellbar
Cliquet courte, réversible



* Renewal Kits → 3749RK → P298

3749SB ⚠

Reversible Ratchet with quick release button
Knarre, verstellbar mit Verriegelungsknopf
Cliquet, réversible avec bouton de débrayage

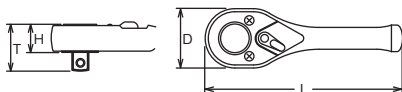

* Renewal Kits → 3749BRK → P298

	D (mm)	T (mm)	H (mm)	L (mm)	(g)	(pcs.)
3749S	34	24.8	14.1	110	183	5
3749SB	34	24.8	14.1	110	183	5

⚠ Reversible Ratchet with quick release button has less strength compared with normal ratchet due to the technical design. Make sure to use the ratchet correctly.

3753SM

Multi Purpose Ratchet, reversible
Knarre mit 2 Vierkantöffnungen, umstellbar
Cliquet réversible deux carrés femelles, réversibles

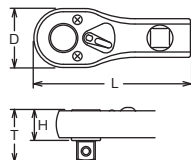

* Renewal Kits → 3753RK → P298

	D (mm)	T (mm)	H (mm)	L (mm)	(g)	(pcs.)
3753SM	30.5	26.4	15.7	81	175	5

3753SMB ⚠

Multi Purpose Ratchet, reversible, with quick release button
Knarre mit 2 Vierkantöffnungen, mit Verriegelungsknopf, umstellbar
Cliquet réversible deux carrés, avec bouton de débrayage

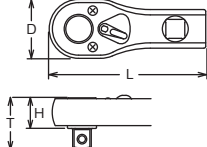

* Renewal Kits → 3753BRK → P298

	D (mm)	T (mm)	H (mm)	L (mm)	(g)	(pcs.)
3753SMB	30.5	26.4	15.7	81	175	5



[L/R Marking]



* Renewal Kits → 3752RK → P298



* Renewal Kits → 3752RK → P298

A pointer and L/R markings on the ratchet head indicate the turning direction. The reduced diameter of the head allows easier access in tight spots.

Eine L/R Markierung auf dem Knarrenkopf zeigt die gerade eingestellte Drehrichtung an. Der geringe Kopfdurchmesser erleichtert das Arbeiten auch an schwer zugänglichen Stellen.

Un marquage L/R sur la tête de cliquet indique le sens de rotation. Le diamètre de tête réduit facilite le travail dans les endroits difficilement accessibles.

	D (mm)	T (mm)	H (mm)	L (mm)	(g)	(pce.)
3752J	33	34.3	23.9	200	310	1
3752N	33	34.3	23.9	200	310	1



3752J Reversible Ratchet
Knarre, verstellbar
Cliquet, réversible



3752N Reversible Ratchet
Knarre, verstellbar
Cliquet, réversible

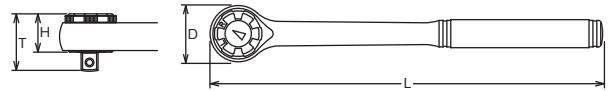

* Renewal Kits → 3753RK → P298



* Renewal Kits → 3753RK → P298



* Renewal Kits → 3753RK → P298



* Renewal Kits → 3753RK → P298

3753J Reversible Ratchet
Knarre, verstellbar
Cliquet, réversible



3753P Reversible Ratchet
Knarre, verstellbar
Cliquet, réversible



3753N Reversible Ratchet
Knarre, verstellbar
Cliquet, réversible



D3753J Reversible Ratchet
Knarre, verstellbar
Cliquet, réversible

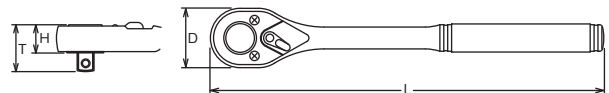

	D (mm)	T (mm)	H (mm)	L (mm)	(g)	(pce.)
3753J	30.5	26.4	15.7	200	260	1
3753P	30.5	26.4	15.7	200	286	1
3753N	30.5	26.4	15.7	200	320	1
D3753J	30.5	26.4	15.7	200	260	1



* Renewal Kits → 3753RK → P298

3753P-250 Reversible Ratchet (Long)
Verstellbare Knarre, lang
Cliquet réversible, long



	D (mm)	T (mm)	H (mm)	L (mm)	(g)	(pce.)
3753P-250	30.5	26.4	15.7	250	335	1

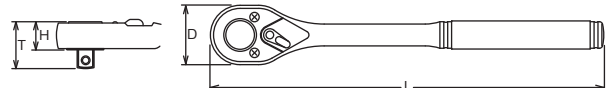

Hand Sockets Hand Steckschlüssel Douilles à main

3/8"

Z-SERIES
HAND
TITANIUM
SCREWDRIVERS ACCESSORIES
IMPACT
SLEEVE-DRIVE
PROTECTOR
INDUSTRIAL
AUTOMOTIVE
CONSTRUCTION MOTORCYCLE
SPARE PART

3753JB Reversible Ratchet with quick release button
Knarre, verstellbar mit Verriegelungsknopf
Cliquet, réversible avec bouton de débrayage



* Renewal Kits → 3753BRK → P298

3753PB Reversible Ratchet with quick release button
Knarre, verstellbar mit Verriegelungsknopf
Cliquet, réversible avec bouton de débrayage



* Renewal Kits → 3753BRK → P298

3753NB Reversible Ratchet with quick release button
Knarre, verstellbar mit Verriegelungsknopf
Cliquet, réversible avec bouton de débrayage



* Renewal Kits → 3753BRK → P298

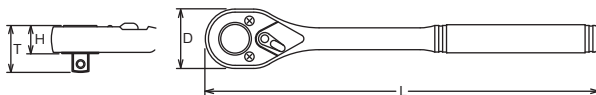

⚠ Reversible Ratchet with quick release button has less strength compared with normal ratchet due to the technical design. Make sure to use the ratchet correctly.

	D (mm)	T (mm)	H (mm)	L (mm)	(g)	(pcs.)
3753JB	30.5	26.4	15.7	200	260	1
3753PB	30.5	26.4	15.7	200	286	1
3753NB	30.5	26.4	15.7	200	320	1

2774JS-3/8 Flexible Ratchet, reversible
Gelenk-Knarre, verstellbar



* Renewal Kits → 2749RK-3/8 → P298

2774PS-3/8 Flexible Ratchet, reversible
Gelenk-Knarre, verstellbar



* Renewal Kits → 2749RK-3/8 → P298

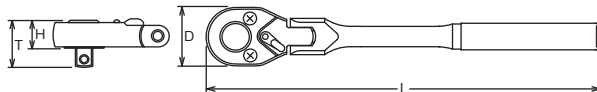

	D (mm)	T (mm)	H (mm)	L (mm)	(g)	(pcs.)
2774JS-3/8	25	21.9	11.2	120	113	5
2774PS-3/8	25	21.9	11.2	120	133	5

⚠ 2774-3/8 series have less strength compared with normal 387 ratchet due to the technical design. Make sure to use the ratchet correctly.

3774PS Flexible Ratchet, reversible
Gelenk-Knarre, verstellbar



* Renewal Kits → 3753RK → P298

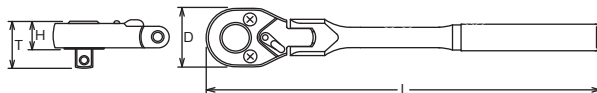

	D (mm)	T (mm)	H (mm)	L (mm)	(g)	(pcs.)
3774PS	30.5	26.4	15.7	175	250	2

3/8" Hand Sockets Hand Steckschlüssel Douilles à main

Z-SERIES
HAND
TITANIUM
ACCESSORIES
SCREWDRIVERS
IMPACT
SLEEVE-DRIVE
PROTECTOR
INDUSTRIAL
AUTOMOTIVE
MOTORCYCLE
CONSTRUCTION
SPARE PART



3774J Flexible Ratchet, reversible
Gelenk-Knarre, verstellbar
Cliquet articulé, réversible

* Renewal Kits → 3753RK → P298



3774P Flexible Ratchet, reversible
Gelenk-Knarre, verstellbar
Cliquet articulé, réversible

* Renewal Kits → 3753RK → P298



3774N Flexible Ratchet, reversible
Gelenk-Knarre, verstellbar
Cliquet articulé, réversible

* Renewal Kits → 3753RK → P298

	D (mm)	T (mm)	H (mm)	L (mm)	(g)	(pcs.)
3774J	30.5	26.4	15.7	285	367	1
3774P	30.5	26.4	15.7	265	378	2
3774N	30.5	26.4	15.7	265	378	2

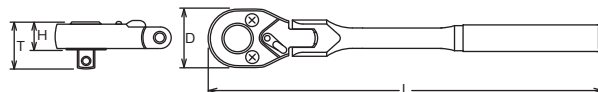

* Renewal Kits → 3753BRK → P298

3774JB
3774PB
3774NB

Flexible Ratchet, reversible with quick release button
Gelenk-Knarre, verstellbar mit Verriegelungsknopf
Cliquet, articulée, réversible avec bouton de débrayage



	D (mm)	T (mm)	H (mm)	L (mm)	(g)	(pcs.)
3774JB	30.5	26.4	15.7	285	367	1
3774PB	30.5	26.4	15.7	265	373	2
3774NB	30.5	26.4	15.7	265	378	2

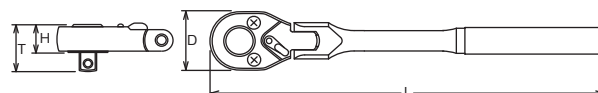

Reversible Ratchet with quick release button has less strength compared with normal ratchet due to the technical design. Make sure to use the ratchet correctly.

Reversible Ratchet with Quick Release Button :

Sockets and accessories are safely locked. By pushing the button the sockets or extension bars are released from the ratchet.

Umstellbare Knarre mit Verriegelungsknopf :

Steckschlüssel und Zubehörteile werden sicher und fest gehalten. Bei Drücken des Knopfes lösen sich die Teile.

Cliquet réversible à verrouillage :

Les douilles et accessoires ne peuvent plus se libérer. Une pression du pouce sur le bouton suffit pour les extraire.

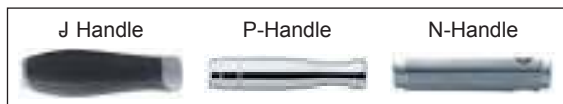

* Renewal Kits → 3753RK → P298

3774JL
3774PL
3774NL

Flex-Head Ratchet with Head Lock Button
Gelenk-Knarre, mit feststellbarem Gelenk
Cliquet à tête articulée avec bouton de blocage



	D (mm)	T (mm)	H (mm)	L (mm)	(g)	(pcs.)
3774JL	30.5	26.4	15.7	285	367	1
3774PL	30.5	26.4	15.7	265	378	2
3774NL	30.5	26.4	15.7	265	378	2

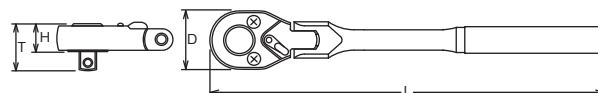

Reversible Ratchet with quick release button has less strength compared with normal ratchet due to the technical design. Make sure to use the ratchet correctly.

Z-SERIES
HAND
TITANIUM
SCREWDRIVERS ACCESSORIES
IMPACT
SLEEVE-DRIVE
PROTECTOR
INDUSTRIAL
AUTOMOTIVE
CONSTRUCTION MOTORCYCLE
SPARE PART

3774JBL Flex-Head Ratchet with Head Lock Button and Quick Release Button
Gelenk-Knarre, mit feststellbarem Gelenk und Verriegelungsknopf
Cliquet à tête articulée avec bouton de blocage et de débrayage



* Renewal Kits → **3753BRK** → **P298**

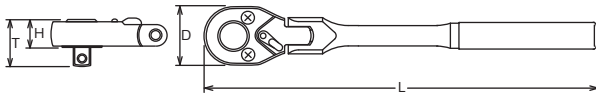
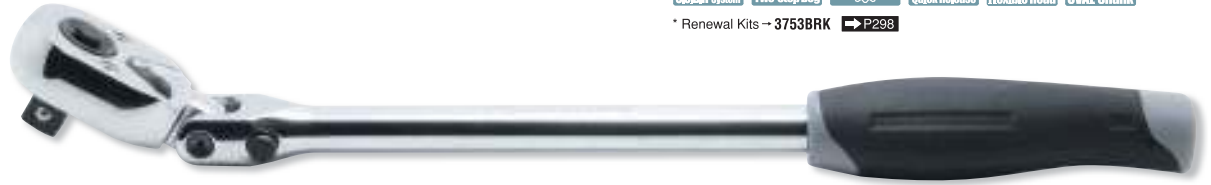

	D (mm)	T (mm)	H (mm)	L (mm)	(g)	(pce.)
3774JBL	30.5	26.4	15.7	285	367	1

⚠ Reversible Ratchet with quick release button has less strength compared with normal ratchet due to the technical design. Make sure to use the ratchet correctly.

3774P-SR Speeder Ratchet
Kurbel-Knarre
Vilebrequin à cliquet



* Renewal Kits → **3753RK** → **P298**

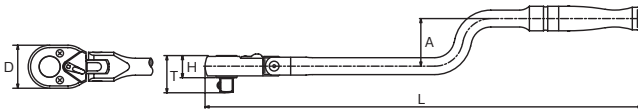

	D (mm)	T (mm)	H (mm)	A (mm)	L (mm)	(g)	(pce.)
3774P-SR	30.5	26.4	15.7	34	310	435	1

3776J Swivel Head Ratchet
Schwenkopf-Knarre
Cliquet à tête pivotante



* Renewal Kits → **3752RK** → **P298**



3776P Swivel Head Ratchet
Schwenkopf-Knarre
Cliquet à tête pivotante



* Renewal Kits → **3752RK** → **P298**



3776N Swivel Head Ratchet
Schwenkopf-Knarre
Cliquet à tête pivotante



* Renewal Kits → **3752RK** → **P298**

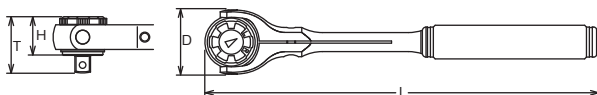

	D (mm)	T (mm)	H (mm)	L (mm)	(g)	(pce.)
3776J	44	34.3	23.9	280	510	1
3776P	44	34.3	23.9	280	560	1
3776N	44	34.3	23.9	280	565	1

45

* Renewal Kits → 3755RK → P300

	D (mm)	L (mm)	(g)	(pcs.)
3755	30.5	55	146	5

	D (mm)	L (mm)	(g)	(pcs.)
3756	30.5	25.5	47	10

L/R Marking
45

* Renewal Kits → 3752RK → P298

	D (mm)	L (mm)	(g)	(pcs.)
3757	50	35	155	5

	D (mm)	L (mm)	(g)	(pcs.)
3762	19.3	300	178	2

3755 Ratchet Adaptor
Aufsteckknarre
Cliquet adaptable

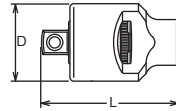

3756 Quick Spinner
Rändel-Drehscheibe
Lanceur

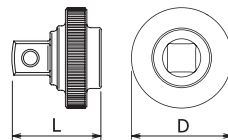

3757 Ratchet Wheel
Umstellbares Knarren-Handrad
Cliquet réversible à roue

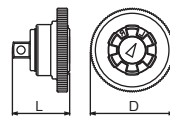

3762 Flexible Extension Bar
Biegsame Verlängerung
Rallonge flexible

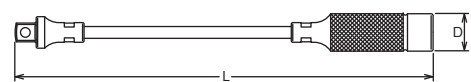

Z-SERIES
HAND
TITANIUM
SCREWDRIVERS ACCESSORIES
IMPACT
SLEEVE-DRIVE
PROTECTOR
INDUSTRIAL
AUTOMOTIVE
MOTORCYCLE
CONSTRUCTION
SPARE PART

3760-32/-50/-75/-125/-150/-250/-300/ -400/-500/-600/-900/-1000

Extension Bars
Verlängerungen
Rallonges

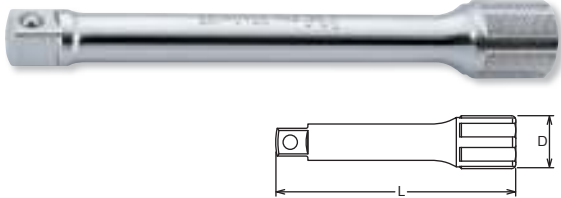

3760	D (mm)	L (mm)	(g)	(pcs.)
32	18	32	27	10
50	18	50	47	10
75	18	75	68	10
125	18	125	106	10
150	18	150	125	10
250	18	250	196	5
300	18	300	291	2
400	18	400	365	1
500	18	500	490	1
600	18	600	538	1
900	18	900	805	1
1000	18	1000	968	1

PK3760/6

Extension Set in Plastic Box
Verlängerungen in Kunststoffkassette
Jeu de rallonges en boîte plastique



PK3760/6 6 Pieces Set/△=670g

PLASTIC TRAY

Extension Bars

3760 Extension Bars
32, 50, 75, 125, 150, 250

Rotation and general handling of extensions with oily hands is greatly improved with the **Koken** developed 6 point knurling. Also the **Koken** 6 point knurling stops the extensions from rolling around the work area.

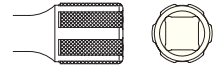

Durch die von **Koken** entwickelte 6 fache Rändelung wird die Handhabung deutlich erleichtert. Außerdem wird das Herumrollen der Verlängerungen wirksam verhindert.

La manipulation des rallonges est grandement facilitée par le profil moleté développé par **Koken**. Ce même profil empêche le roulement intempestif des rallonges sur le plan de travail.

3763-32/-50/-75/-125/-150/-250/-300

Wobble-Fix Extension Bars
Winkel-Verlängerungen
Rallonges angulaires

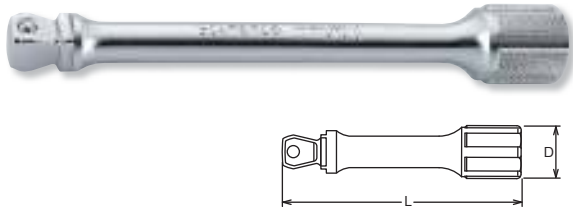

3763	D (mm)	L (mm)	(g)	(pcs.)
32	18	32	26	10
50	18	50	42	10
75	18	75	57	10
125	18	125	80	10
150	18	150	98	10
250	18	250	144	5
300	18	300	170	2

PK3763/6

Wobble-Fix Extension Bars in Plastic Box
Winkel-Verlängerungen in Kunststoffkassette
Jeu de rallonges angulaires en boîte plastique



PK3763/6 6 Pieces Set/△=560g

PLASTIC TRAY

Extension Bars

3763 Wobble-Fix Extension Bars
32, 50, 75, 125, 150, 250

Wobble-Fix Extension Bar

Two way usage

- In a fixed position, as a normal extension bar
- In a half-fixed position, as a flexible extension bar providing a 15° angle operation

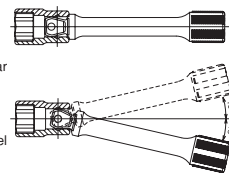

Winkel-Verlängerungen

Winkelverlängerungen lassen sich in zwei

Einstellungen verwenden

- voll eingesteckt und starr,
- halb eingesteckt, mit einem Arbeitswinkel von 15°.

Rallonges angulaires

Deux utilisations possibles

- comme rallonge normale, dans une position fixe
- comme une rallonge angulaire avec une possibilité d'inclinaison jusqu'à 15°

The Wobble-Fix Extension Bar has less strength than normal extension bar due to it's specific design with a reduced square drive. Make sure to use it correctly.



* Renewal Kits → 3768RK → P300

3768J-250 Hinge Handle
Gelenkgriff
Poignée articulée



3768P-250 Hinge Handle
Gelenkgriff
Poignée articulée



* Renewal Kits → 3768RK → P300

3768P-380 Hinge Handle ⚠
Gelenkgriff
Poignée articulée



	D (mm)	L (mm)	(g)	(pcs.)
3768J-250	20.5	250	248	2
3768P-250	20.5	250	275	5
3768P-380	20.5	380	435	2

⚠ 3768P-380 has longer handle than standard, and can be loaded to excessive torque value. In the interest of your own safety always apply load evenly and progressively to avoid breakage and possible injury.

Der Gelenkgriff 3768-380 ist länger als die Standardversion. Aus Gründen Ihrer Sicherheit, sollten dies Werkzeug nie ruckartig sondern nach und nach belastet werden, um Bruch und damit verbundene, mögliche Verletzungen zu vermeiden.

Du au fait que les manches des 3768-380 sont plus longues que le standard, il y a risque d'une surcharge excessive lors du serrage. Pour éviter casse et blessure, veuillez serrer d'une façon régulière et progressive.

3769N	ℓ (mm)	L (mm)	(g)	(pcs.)
160	50	160	96	2
230	120	230	126	2

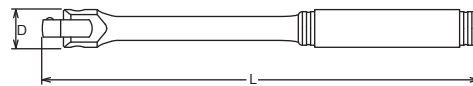

3769N-160/-230 Spin Type Handle ⚠
Drehgriff
Poignée emmanchée

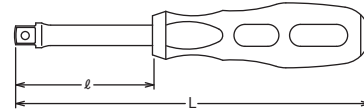

3769NWF-160/-230 Spin Type Handle Wobble-Fix ⚠
Drehgriff, Wobble-Fix
Poignée emmanchée, angulaire

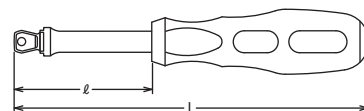

3769NWF	ℓ (mm)	L (mm)	(g)	(pcs.)
160	50	160	96	2
230	120	230	126	2

⚠ Plastic or rubber handles are not intended to act as insulation.

Plastik-oder Gummigriffe stellen keinen Isolierschutz dar.

Les poignées en plastique ou en caoutchouc ne garantissent aucune isolation électrique.

3769H	L (mm)	(g)	(pcs.)
3769H	170	210	2

3769H Folding Socket Driver
Klapp-Drehgriff
Poignée tournevis articulée

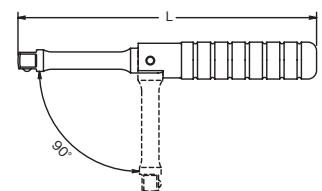

Hand Sockets Hand Steckschlüssel Douilles à main

3/8"

Z-SERIES

HAND

TITANIUM

SCREWDRIVERS ACCESSORIES

IMPACT

SLEEVE-DRIVE

PROTECTOR

INDUSTRIAL

AUTOMOTIVE

MOTORCYCLE

SPARE PART CONSTRUCTION

3770 Universal Joint
Gelenk-Einsatz
Cardan universel

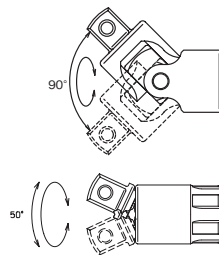
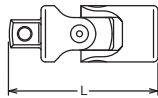

3771 Universal Joint
Gelenk-Einsatz
Joint articlé

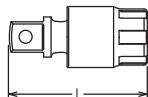

	L (mm)	⚖️ (g)	📦 (pcs.)
3770	50	66	10
3771	43	46	10

3780 Speed Handle
Winde
Vilebrequin

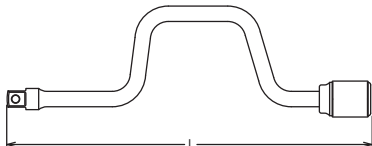

	L (mm)	⚖️ (g)	📦 (pce.)
3780	400	432	1

3785 T-Handle
T-Griff
Poignée coulissante

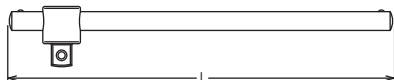

Innovative Oval shaped bar provides higher durability and stops the sliding square part turning around the bar.



3322A Adaptor
Verbindungsstück
Augmentateur

Warranty 86Nm
Garantie 86Nm
Garantie 86Nm

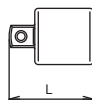

3344A Adaptor
Verbindungsstück
Augmentateur

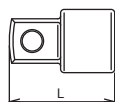

	L (mm)	⚖️ (g)	📦 (pcs.)
3785	200	157	5

	♁ (sq)	♁ (sq)	L (mm)	⚖️ (g)	📦 (pcs.)
3322A	3/8"	1/4"	24	18	10
3344A	3/8"	1/2"	30	35	10

⚠️ Adapting down from bigger square drive to smaller square drive may lead to excessive torque and possibly cause breakage.

Reduzierstücke sind mit Vernunft einzusetzen.
Es besteht Bruchgefahr. Überschreiten Sie niemals die Sicherheitsgrenzen.

Les réducteurs doivent être utilisés avec modération. Ne dépassez jamais la limites de sécurité.





PK2346/6 Adaptor Set in Plastic Box
Adaptor Satz in Kunststoffkassette
Jeu de adaptateur en boîte plastique



2233A	Ⓜ️ (1/4") X 3/8"		
3322A	Ⓜ️ (3/8") X 1/4"	Warranty/Garantia	86Nm
3344A	Ⓜ️ (3/8") X 1/2"		
4433A	Ⓜ️ (1/2") X 3/8"	Warranty/Garantia	290Nm
4466A	Ⓜ️ (1/2") X 3/4"		
6644A	Ⓜ️ (3/4") X 1/2"	Warranty/Garantia	668Nm

PK2346/6 6 Pieces Set/⚖️=460g
PLASTIC TRAY

Adaptors	
1/4"♁→3/8"♁ 2233A	3/8"♁→1/4"♁ 3322A
3/8"♁→1/2"♁ 3344A	1/2"♁→3/8"♁ 4433A-35
1/2"♁→3/4"♁ 4466A	3/4"♁→1/2"♁ 6644A

ESH3001 17 Pieces Set/△=2,200g	
METAL CASE:W415xH120xT50mm	
Sockets	Accessories
3410M Surface Drive Sockets 8, 9, 10, 11, 12, 13, 14, 15, 16, 17, 18, 19	 3753J  3760-125  3760-250  3770  3785











ESH3001 Socket Set
Steckschlüssel Satz
Jeu de clés à douille

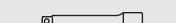

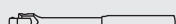
ETH3001 22 Pieces Set/△=1,820g	
METAL CASE:W392xH90xT50mm	
Sockets	Accessory
3425 TORX® Sockets E4, E5, E6, E7, E8 4425 TORX® Sockets E10, E11, E12, E14, E16, E18 3025.50 TORX® Bit Sockets T10, T15, T20, T25, T27 4025.60 TORX® Bit Sockets T30, T40, T45, T50, T55	 4433A-35





ETH3001 Socket Set
Steckschlüssel Satz
Jeu de clés à douille



3201AMW 42 Pieces Set/△=4,700g	
METAL CASE:W445xH190xT50mm	
Sockets	Accessories
3405M 12-pt. Sockets 9, 10, 11, 12, 13, 14, 15, 16, 17, 18, 19, 20, 21, 22 3405A 12-pt. Sockets 5/16, 3/8, 7/16, 1/2, 9/16, 5/8, 11/16, 3/4, 25/32, 13/16, 7/8 3405W 12-pt. Sockets 1/8, 3/16, 1/4, 5/16, 3/8, 7/16, 1/2	 3753N  3760-75  3760-125  3760-250  3768N-250  3769N-160  3770  3780  3785  3344A





3201AMW Socket Set
Steckschlüssel Satz
Jeu de clés à douille



3206AM 27 Pieces Set/△=3,500g	
METAL CASE:W445xH190xT50mm	
Sockets	Accessories
3405M 12-pt. Sockets 7, 8, 10, 11, 12, 13, 14, 15, 16, 17, 19, 22 3405A 12-pt. Sockets 3/8, 7/16, 1/2, 9/16, 5/8, 11/16, 3/4, 13/16, 7/8 3300C Spark Plug Socket 20.8	 3753J  3760-125  3760-250  3768J-250  3770

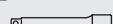
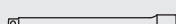



3206AM Socket Set
Steckschlüssel Satz
Jeu de clés à douille

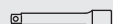

3210M-00 22 Pieces Set/△=2,900g 3210M-05 22 Pieces Set/△=2,900g 3210M-10 22 Pieces Set/△=2,900g	
METAL CASE:W360xH145xT50mm	
Sockets	Accessories
(3210M-00) 3400M 6-pt. Sockets 6, 7, 8, 9, 10, 11, 12, 13, 14, 15, 16, 17, 18, 19, 21, 22 (3210M-05) 3405M 12-pt. Sockets 6, 7, 8, 9, 10, 11, 12, 13, 14, 15, 16, 17, 18, 19, 21, 22 (3210M-10) 3410M Surface Drive Sockets 6, 7, 8, 9, 10, 11, 12, 13, 14, 15, 16, 17, 18, 19, 21, 22	 3753J  3760-125  3760-250  3768J-250  3770  3785

3210M-00 / 3210A-00 Socket Set
Steckschlüssel Satz
Jeu de clés à douille
3210M-05
3210M-10



3210A-00 18 Pieces Set/△=2,760g	
METAL CASE:W360xH145xT50mm	
Sockets	Accessories
3400A 6-pt. Sockets 1/4, 5/16, 11/32, 3/8, 7/16, 1/2, 9/16, 5/8, 11/16, 3/4, 13/16, 7/8	 3753J  3760-125  3760-250  3768J-250  3770  3785

Z-SERIES
HAND
TITANIUM
ACCESSORIES
SCREWDRIVERS
IMPACT
SLEEVE-DRIVE
PROTECTOR
INDUSTRIAL
AUTOMOTIVE
MOTORCYCLE
CONSTRUCTION
SPARE PART

3216 Spark Plug Sockets Set
Zündkerzen-Schlüssel Satz
Jeu de douilles pour bougies



3216		4 Pieces Set/△=730g	
PLASTIC BAG			
Sockets		Accessories	
	3300C Spark Plug Sockets 16, 20.8		3760-125
			3774JL

3217M-00 Socket Set
Steckschlüssel Satz
Jeu de clés à douille
3217M-05
3217M-10



3217M-00		14 Pieces Set/△=850g	
3217M-05		14 Pieces Set/△=850g	
3217M-10		14 Pieces Set/△=850g	
METAL CASE:W163xH52xT33mm			
Sockets			
	(3217M-00) 3400M 6-pt. Sockets 9, 10, 11, 12, 13, 14, 15, 16, 17, 18, 19, 20, 21, 22		
	(3217M-05) 3405M 12-pt. Sockets 9, 10, 11, 12, 13, 14, 15, 16, 17, 18, 19, 20, 21, 22		
	(3217M-10) 3410M Surface Drive Sockets 9, 10, 11, 12, 13, 14, 15, 16, 17, 18, 19, 20, 21, 22		

S3240M-00 / S3240A-00 Display Stands
Ausstellungsstände
S3240M-05 / S3240A-05 Présentoirs



S3240M-00		3400M 177 Pieces Set/△=10,300g	
S3240M-05		3405M 177 Pieces Set/△=10,300g	
DISPLAY STAND:W510xH150xT230mm			
Sockets			
6mm:12pcs	12mm:12pcs	18mm:8pcs	
7mm:12pcs	13mm:11pcs	19mm:8pcs	
8mm:12pcs	14mm:11pcs	20mm:7pcs	
9mm:12pcs	15mm:10pcs	21mm:7pcs	
10mm:12pcs	16mm: 9pcs	22mm:7pcs	
11mm:12pcs	17mm: 9pcs	23mm:6pcs	

S3240A-00		3400A 126 Pieces Set/△=8,500g	
S3240A-05		3405A 126 Pieces Set/△=8,500g	
DISPLAY STAND:W510xH150xT230mm			
Sockets			
1/4" :12pcs	9/16":10pcs	25/32":7pcs	
5/16":12pcs	19/32":10pcs	13/16":7pcs	
3/8" :12pcs	5/8" : 9pcs	7/8" :7pcs	
7/16":12pcs	11/16": 9pcs		
1/2" :11pcs	3/4" : 8pcs		





3250M-00 Socket Set
Steckschlüssel Satz
Jeu de clés à douille
3250M-05



3250M-00		17 Pieces Set/△=2,200g	
3250M-05		17 Pieces Set/△=2,200g	
METAL CASE:W415xH120xT50mm			
Sockets		Accessories	
	3400M 6-pt. Sockets 7, 8, 10, 11, 12, 13, 14, 15, 16, 17, 18, 19		3753J
			3760-125
	3405M 12-pt. Sockets 7, 8, 10, 11, 12, 13, 14, 15, 16, 17, 18, 19		3760-250
			3770
			3785

3251 8 Pieces Set/△=675g

METAL CASE:W160xH100xT28mm

Sockets	Accessories
 3025.50 TORX® Bit Sockets T25H, T30H, T40H, T45H, T50H	 2774PS-3/8
	 3763-50
	 3756







3251

Bit Socket Set
Schraubendreher-Steckschlüssel Satz
Jeu de douilles de vissage



3252M 15 Pieces Set/△=1.530g

METAL CASE:W310xH90xT48mm

Sockets	Accessories
 3400M 6-pt. Sockets 5.5, 7, 8, 10, 11, 12	 3753P
 3405M 12-pt. Sockets 13, 14, 17, 19, 22	 3760-75
	 3760-125
	 3770









3252M

Socket Set
Steckschlüssel Satz
Jeu de clés à douille



3275 24 Pieces Set/△=3.150g

METAL CASE:W400xH147xT50mm

Sockets	Accessories
 3400M 6-pt. Sockets 6, 7, 8, 9, 10, 11, 12	 3753J
 3405M 12-pt. Sockets 13, 14, 15, 16, 17, 18, 19, 21, 22	 3760-125
 3300C Spark Plug Sockets 16, 20.8	 3760-250
	 3768J-250
	 3770
	 3756







3275

Socket Set
Steckschlüssel Satz
Jeu de clés à douille

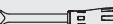

3277 29 Pieces Set/△=3.240g

METAL CASE:W370xH150xT50mm

Sockets	Accessories
 3400M 6-pt. Sockets 8, 9, 10, 11, 12	 3753J
 3405M 12-pt. Sockets 13, 14, 15, 16, 17, 18, 19, 21	 3760-125
 3300M 6-pt. Deep Sockets 8, 9, 10, 11, 12	 3768J-250
 3305M 12-pt. Deep Sockets 13, 14, 15, 16, 17, 18, 19, 21	







3277

Socket Set
Steckschlüssel Satz
Jeu de clés à douille



3278 20 Pieces Set/△=3.370g

METAL CASE:W310xH150xT50mm

Sockets	Accessories
 3000 Bit Sockets 2, 3	 3753J
 3010M.62 Hex Bit Sockets 5, 6, 7, 8, 10	 3763-125
 3020.50 XZN Bit Sockets M4, M5, M6, M8	
 3025.50 TORX® Bit Sockets T10, T15, T20, T25, T27, T30, T40	

3278

Bit Socket Set
Schraubendreher-Steckschlüssel Satz
Jeu de douilles de vissage



All socket sets can be supplied either with 6-pt. or with 12-pt. opening.
Alle Steckschlüsselsätze sind mit 6- oder 12-kant Steckschlüsseln erhältlich.
Tous les coffrets de douilles peuvent être livrés en 6- ou 12-pans.

Z-SERIES
HAND
TITANIUM
SCREWDRIVERS ACCESSORIES
IMPACT
SLEEVE-DRIVE
PROTECTOR
INDUSTRIAL
AUTOMOTIVE
CONSTRUCTION MOTORCYCLE
SPARE PART

4401M 6-point Sockets 6-kant Steckschlüssel Douilles 6-pans

HANDY-ENDY®

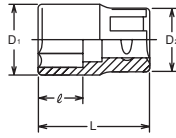

4406M 12-point Sockets 12-kant Steckschlüssel Douilles 12-pans

HANDY-ENDY®

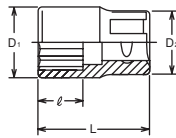

4400M 6-point Sockets 6-kant Steckschlüssel Douilles 6-pans

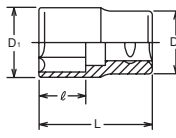



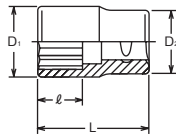

4405M 12-point Sockets 12-kant Steckschlüssel Douilles 12-pans



RS4401M/10 Socket Set on Rail Steckschlüsselsatz auf Schiene Jeu de douilles sur rail



4401M 4406M (mm)	D ₁ (mm)	D ₂ (mm)	ℓ (mm)	L (mm)	 (g)	 (pcs.)
8	13.2	22	8	36	44	10
9	13.8	22	8.5	37	44	10
10	15.3	22	9	37	45	10
11	16.5	22	9.5	37	46	10
12	17.8	22	10	37	47	10
13	19	22	10.5	37	53	10
14	20.3	22	11	37	56	10
15	21.5	22	11.5	37	52	10
16	22.8	22	12	37	62	10
17	24	22	12.5	37	69	10
18	25	23	13	37	74	10
19	26.5	24.5	14	38	89	10
20	27.8	26	15	38	92	10
21	29	27	15.5	38	102	10
22	30	28	16	40	113	10
23	31.5	29	16.5	40	128	10
24	32.8	30	17	42	140	5
25	34	31	18	42	164	5
26	35	32	19	42	165	5
27	36.5	33	19.5	43	196	5
28	37.8	34	20	43	198	5
29	39	35	20.5	43	190	5
30	40	36	22	46	222	5
31	41.5	37	22.5	46	257	5
32	42.8	38	23	46	250	5

4400M 4405M (mm)	D ₁ (mm)	D ₂ (mm)	ℓ (mm)	L (mm)	 (g)	 (pcs.)
33	44.2	39	24	47	275	5
34	45.2	40	24	47	315	5
35	46.2	40	24	47	317	5
36	47.2	41	24	47	336	5
37	48.3	42	24	47	360	5
38	49.2	43	24	47	380	5
41	53.1	45	29	57	471	5
46	59.1	48	32	60	567	2

RS4406M/10 Socket Set on Rail Steckschlüsselsatz auf Schiene Jeu de douilles sur rail



RS4401M/10	10 Pieces Set/Rail 300mm	 (g)
10, 11, 12, 13, 14, 15, 16, 17, 18, 19		720

RS4406M/10	10 Pieces Set/Rail 300mm	 (g)
10, 11, 12, 13, 14, 15, 16, 17, 18, 19		720

1/2"

Hand Sockets
Hand Steckschlüssel
Douilles à main

	4400A 4405A (inch)	D ₁ (mm)	D ₂ (mm)	ℓ (mm)	L (mm)	(g)	(pcs.)
New	1/4	10.7	21	6	36	41	10
	5/16	13.2	21	8	36	44	10
	3/8	14.6	21	9	37	45	10
	7/16	16.5	21	9.5	37	46	10
	1/2	19	22	10.5	37	53	10
	9/16	20.3	22	11	37	56	10
	19/32	21.5	22	11.5	37	52	10
	5/8	22.8	22	12	37	62	10
	21/32	24	23	12.5	37	69	10
	11/16	25	24	13	37	74	10
	3/4	26.5	25	14	38	89	10
	25/32	27.8	26	15	38	92	10
	13/16	29	27	15.5	38	102	10
	7/8	30	28	16	40	113	10
	15/16	32.8	30	17	42	140	5
	31/32	34	31	18	42	165	5
	1	35	32	19	42	165	5
	1. 1/16	36.5	33	19.5	43	180	5
	1. 1/8	39	35	20.5	43	210	5
	1. 3/16	40	36	22	46	222	5
	1. 1/4	42.8	38	23	46	250	5
	1. 5/16	44.2	39	24	47	275	5
	1. 3/8	46.2	40	24	47	317	5
	1. 7/16	47.2	41	24	47	336	5
	1. 1/2	49.2	43	24	47	380	5

Hand Sockets

Both, 6-pt. and 12-pt. openings, are equipped with Flat Drive Openings, transferring the turning power from the corners on the flanks of nuts and bolts.

Sowohl 6-kant als auch 12-kant Steckschlüssel bieten alle Vorteile der "Flat Drive" Öffnung, die die Greifzonen auf die Flächen von Schrauben und Muttern versetzt.

Aussi bien les douilles 6-pans que 12-pans présentent tous les avantages liés au profil FLATDRIVE qui applique la force de serrage aux faces de la vis ou de l'écrou.

4400A 6-point Sockets 6-kant Steckschlüssel Douilles 6-pans

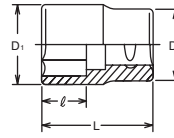

4405A 12-point Sockets 12-kant Steckschlüssel Douilles 12-pans

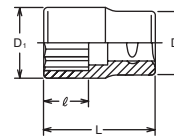









RS4400A/10	10 Pieces Set/Rail 300mm	
3/8, 7/16, 1/2, 9/16, 5/8, 11/16, 3/4, 13/16, 7/8, 15/16		809

RS4405A/10	10 Pieces Set/Rail 300mm	
3/8, 7/16, 1/2, 9/16, 5/8, 11/16, 3/4, 13/16, 7/8, 15/16		809

RS4400A/10 Socket Set on Rail Steckschlüsselsatz auf Schiene Jeu de douilles sur rail

RS4405A/10 Socket Set on Rail Steckschlüsselsatz auf Schiene Jeu de douilles sur rail



	 6-Point	 12-Point	 Surface Drive	 Nut Grip®	 TORX® (E)	 TORXPLUS® (EPL)	 Double Square	 LHSTIX® (LH-S)
1/4"	No. 2400M/A No. 2300M/A No. 2400W-BA No. 2300W-BA No. 2300X series	No. 2405M/A No. 2305M/A No. AS2405A No. AS2305A series	No. 2410M No. 2310M series	No. 2450MS No. 2350M No. 2350X series	No. 2425 No. 2325 series	—	No. 2415M/A series	—
3/8"	No. 3400M/A No. 3300M/A No. 3400W No. 3300W No. 3300X/XA series	No. 3405M/A No. 3305M/A No. 3405W No. 3305W No. 3350X/XA series	No. 3410M No. 3310M series	No. 3450M No. 3350M No. 3350X series	No. 3425 No. 3325 series	—	No. 3415M/A series	No. 3400LH series
1/2"	No. 4400M/A No. 4401M No. 4300M/A No. 4400W series	No. 4405M/A No. 4406M No. 4305M/A No. 4405W series	No. 4410M No. 4310M series	No. 4450M series	No. 4425 No. 4325 series	No. 4425-EPL series	—	No. 4400LH series

4410M

Surface Drive Sockets
Surface Drive Steckschlüssel
Douilles, Surface Drive

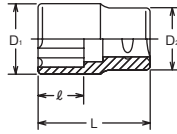

RS4410M/10

Socket Set on Rail
Steckschlüsselsatz auf Schiene
Jeu de douilles sur rail



SURFACE DRIVE

Surface drive sockets are designed to retain contact with the flat sides of the nut in order to transmit higher torque and reduce nut wear. These sockets are ideal for using on polished nuts, aluminum nuts and nuts with worn out points.

Das Profil unserer Surface-Drive Steckschlüssel greift die Schraube an deren Flächen. Dies sichert eine höhere Kraftübertragung und verhindert ein Durchrutschen des Steckschlüssels. Diese Steckschlüssel eignen sich besonders für polierte Schrauben, Aluminium Schrauben und Schrauben bei denen die Ecken bereits abgerundet sind.

Notre profil Surface Drive assure le contact entre la douille et les plats de l'écrou. Ceci réduit l'usure et permet la transmission d'un couple plus élevé. C'est une solution idéale pour les écrous polies, celles en aluminium ou arrondies.



4410M (mm)	D ₁ (mm)	D ₂ (mm)	ℓ (mm)	L (mm)	(g)	(pcs.)
8	13.2	21	8	36	44	10
9	13.8	21	8.5	37	44	10
10	15.3	21	9	37	45	10
11	16.5	21	9.5	37	46	10
12	17.8	21	10	37	47	10
13	19	22	10.5	37	53	10
14	20.3	22	11	37	56	10
15	21.5	22	11.5	37	52	10
16	22.8	22	12	37	62	10
17	24	23	12.5	37	69	10
18	25	24	13	37	74	10
19	26.5	25	14	38	89	10
20	27.8	26	15	38	92	10
21	29	27	15.5	38	102	10
22	30	28	16	40	113	10
23	31.5	29	16.5	40	128	10
24	32.8	30	17	42	140	5
25	34	31	18	42	164	5
26	35	32	19	42	165	5
27	36.5	33	19.5	43	196	5
28	37.8	34	20	43	198	5
29	39	35	20.5	43	190	5
30	40	36	22	46	222	5
31	41.5	37	22.5	46	257	5
32	42.8	38	23	46	250	5
34	45.2	40	24	47	314	5

RS4410M/10	10 Pieces Set/Rail 300mm	(g)
10, 11, 12, 13, 14, 15, 17, 19, 21, 22		717

4400W

6-point Whitworth Sockets
6-kant Steckschlüssel, Whitworth
Douilles à 6-pans Whitworth

4405W

12-point Whitworth Sockets
12-kant Steckschlüssel, Whitworth
Douilles à 12-pans Whitworth

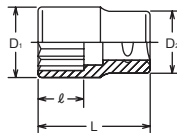

RS4400W/8

Socket Set on Rail
Steckschlüsselsatz auf Schiene
Jeu de douilles sur rail



4400W / 4405W (W)	D ₁ (mm)	D ₂ (mm)	ℓ (mm)	L (mm)	(g)	(pcs.)
3/16	16.5	21	9.5	37	46	10
1/4	19	22	10.5	37	54	10
5/16	21.5	22	11.5	37	54	10
3/8	25	24	13	37	73	10
7/16	29	27	15.5	38	87	10
1/2	31.5	29	16.5	40	133	10
9/16	35	32	19	42	165	5
5/8	37.8	34	20	43	191	5
11/16	40	36	22	46	222	5
3/4	44.2	39	24	47	280	5

RS4400W/8	8 Pieces Set/Rail 250mm	(g)
3/16, 1/4, 5/16, 3/8, 7/16, 1/2, 9/16, 5/8		860

RS4405W/8	8 Pieces Set/Rail 250mm	(g)
3/16, 1/4, 5/16, 3/8, 7/16, 1/2, 9/16, 5/8		860

BS W



BS - W	BS	3/16BS	1/4BS	5/16BS	3/8BS	7/16BS	1/2BS	9/16BS	5/8BS	11/16BS	3/4BS	7/8BS
	W	1/8W	3/16W	1/4W	5/16W	3/8W	7/16W	1/2W	9/16W	5/8W	11/16W	3/4W
Across Flat	(ref. mm)	8.6	11.3	13.3	15.2	18.0	20.8	23.4	25.7	27.9	30.5	33.4

4425-N

TORX® Sockets
TORX® Steckschlüssel
Douilles TORX®

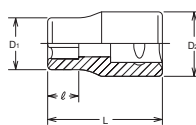

RS4425/6-N

Socket Set on Rail
Steckschlüsselsatz auf Schiene
Jeu de douilles sur rail



4425 (E)	D ₁ (mm)	D ₂ (mm)	ℓ (mm)	L (mm)	(g)	(pcs.)
E10N	13.2	21	8.2	36	47	10
E12N	14.6	21	9.3	37	48	10
E14N	16.5	21	10.6	37	50	10
E16N	19	22	11.8	37	60	10
E18N	20.3	22	13	37	60	10
E20N	22.8	22	14.4	37	65	10

TORX Socket for Nut and low profile bolt
Shallow Chamfer on Socket Opening



A : Flywheel bolt MR20 NISSAN: 4425-E20N
B : Cam sprocket FA20 for TOYOTA/SUBARU: 4425-E16N
C : Connecting rod bolt FA20 for TOYOTA/SUBARU: 4425-E14N

RS4425/6-N	6 Pieces Set/Rail 200mm	(g)
E10N, E12N, E14N, E16N, E18N, E20N		370

4425 (E)	D ₁ (mm)	D ₂ (mm)	ℓ (mm)	L (mm)	(g)	(pcs.)
E 8	10.7	21	7	36	41	10
E10	13.2	21	8.2	36	44	10
E11	13.8	21	8.7	37	45	10
E12	14.6	21	9.3	37	47	10
E14	16.5	21	10.6	37	48	10
E16	19	22	11.8	37	57	10
E18	20.3	22	13	37	57	10
E20	22.8	22	14.4	37	63	10
E22	25	24	15.5	37	78	10
E24	26.5	25	17	40	95	5

4425 TORX® Sockets TORX® Steckschlüssel Douilles TORX®

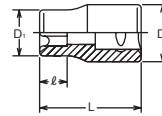

TORX® (E)

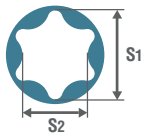

E	E4	E5	E6	E7	E8	E10	E11	E12	E14	E16	E18	E20	E22	E24	E26	E28
S ₁ (ref. mm)	3.7	4.6	5.6	6.1	7.4	9.3	9.9	11.0	12.8	14.6	16.5	18.3	20.1	22.0	23.7	25.5
S ₂ (ref. mm)	2.7	3.3	4.0	4.3	5.3	6.8	7.1	7.9	9.2	10.5	11.9	13.2	14.8	15.7	17.5	18.3

RS4425/7	7 Pieces Set/Rail 200mm	(g)
E10, E12, E14, E16, E18, E20, E24		428

RS4425/7 Socket Set on Rail Steckschlüsselsatz auf Schiene Jeu de douilles sur rail



4425 (EPL)	D ₁ (mm)	D ₂ (mm)	ℓ (mm)	L (mm)	(g)	(pcs.)
10EPL	13.2	21	6.2	36	45	10
12EPL	14.6	21	7.2	37	47	10
14EPL	16.5	21	8.1	37	49	10
16EPL	19	22	9.2	37	60	10
18EPL	20.3	22	10.2	37	60	10
20EPL	22.9	22	11.2	37	65	10

4425 (EPL) TORXPLUS® Sockets TORXPLUS® Steckschlüssel Douilles TORXPLUS®

TORXplus®

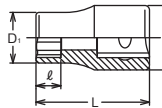

RS4425/6-EPL	6 Pieces Set/Rail 200mm	(g)
10EPL, 12EPL, 14EPL, 16EPL, 18EPL, 20EPL		390

RS4425/6-EPL Socket Set on Rail Steckschlüsselsatz auf Schiene Jeu de douilles sur rail



TORX PLUS
EP/EPL-style



TORX
E-style



Straight Sidewalls & Reduced Recess Fall Away

- Increase tool engagement
- Virtually eliminates camout
- Ensures proper torque transfer
- Greatly reduces end load requirements
- Can reduce worker fatigue and muscular stress during manual assembly

Elliptically-based Geometry and Lobe Engagement

- Broadens contact surface to maximize engagement of driver and recess
- Eliminates damaging point-to-point contact

0° Drive Angle

- Optimises torque transmission
- Virtually eliminates radial stresses to increase tool bit life
- Enables use of recesses with thinner walls

Six Lobes with Large Cross-Sectional Areas

- Enables faster tool engagement
- Maximizes torque transfer
- Increases torsional strength

TORX is a registered trademark of Acument Intellectual Properties, LLC.
TORX ist ein registriertes Markenzeichen der Firma Acument Intellectual Properties, LLC.
TORX est une marque déposée de Acument Intellectual Properties, LLC.

TORXplus is a registered trademark of Acument Intellectual Properties, LLC.
TORXplus ist ein registriertes Markenzeichen der Firma Acument Intellectual Properties, LLC.
TORXplus est une marque déposée de Acument Intellectual Properties, LLC.

Hand Sockets Hand Steckschlüssel Douilles à main

1/2"

Z-SERIES
HAND
TITANIUM
ACCESSORIES
SCREWDRIVERS
IMPACT
SLEEVE-DRIVE
PROTECTOR
INDUSTRIAL
AUTOMOTIVE
MOTORCYCLE
CONSTRUCTION
SPARE PART

4400LH

 LHSTIX® Sockets
Steckschlüssel mit LHSTIX® Profil
Douilles au profil LHSTIX®

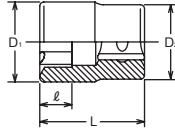

4400LH (LH-S)	D ₁ (mm)	D ₂ (mm)	ℓ (mm)	L (mm)	(g)	(pcs.)
6S	13.2	21	5.6	36	44	10
8S	16.5	21	6.8	37	46	10
10S	19	22	8	37	53	10
12S	22.8	22	9.2	37	62	10
14S	25	24	10.4	37	74	10
16S	29	27	11.6	38	102	10

LHSTIX®

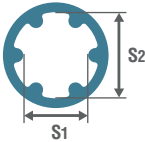

LH-S	LH-5S	LH-6S	LH-8S	LH-10S	LH-12S	LH-14S	LH-16S
S ₁ (ref. mm)	5.6	6.8	9.0	11.3	13.6	15.8	18.1
S ₂ (ref. mm)	7.5	9.0	12.0	15.0	18.0	21.0	24.0

RS4400LH/6

  Socket Set on Rail
Steckschlüsselsatz auf Schiene
Jeu de douilles sur rail



RS4400LH/6	6 Pieces Set/Rail 200mm	(g)
6S, 8S, 10S, 12S, 14S, 16S		430

4450M

 Nut Grip® Sockets
Steckschlüssel mit 2-facher Kugelhalterung
Douilles à billes de retenue

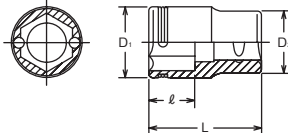

NUT GRIP®

Twin balls at the 6-point opening hold bolt/nut tightly for safe and reliable work.

Die zwei Kugeln in der 6-kant Öffnung unserer NUT GRIP Steckschlüssel halten die Schraube sicher im Steckschlüssel. Dies erlaubt ein Arbeiten auch an schwer zugänglichen Stellen.

Les 2 billes dans l'ouverture du 6-pans de la douille retiennent l'écrou de manière sûre et efficace.

4450M (mm)	D ₁ (mm)	D ₂ (mm)	ℓ (mm)	L (mm)	(g)	(pcs.)
10	15.3	21	6	36	44	10
11	16.5	21	6.5	36	46	10
12	17.8	21	7	36	46	10
13	19	22	8	36	52	10
14	20.3	22	8.5	36	54	10
15	21.5	22	9	36	52	10
16	22.8	22	9	36	60	10
17	24	23	9.5	36	68	10
18	25	24	10.5	36	77	10
19	26.5	25	11.5	36	85	10
21	29	27	12	37	110	10
22	30	28	12.5	37	105	10
24	32.8	30	14.5	39	130	5
27	36.5	33	16.5	40	139	5

RS4450M/10

  Socket Set on Rail
Steckschlüsselsatz auf Schiene
Jeu de douilles sur rail



RS4450M/10	10 Pieces Set/Rail 300mm	(g)
10, 11, 12, 13, 14, 15, 17, 19, 21, 22		717

1/2"

Hand Sockets
Hand Steckschlüssel
Douilles à main

4300M / 4300A

6-point Deep Sockets
6-kant Steckschlüssel, lang
Douilles longues, 6-pans

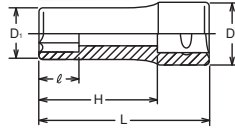

4300M 4305M (mm)	D ₁ (mm)	D ₂ (mm)	ℓ (mm)	H (mm)	L (mm)	(g)	(pcs.)
8	13.2	21	9	59	77	76	10
9	13.8	21	10	59	77	82	10
10	15.3	21	11	59	77	82	10
11	16.5	21	12	59	77	86	10
12	17.8	21	13	59	77	92	10
13	19	21.8	14	59	77	106	10
14	20.3	21.8	15	59	77	115	10
15	21.5	21.8	16	59	77	123	10
16	22.8	22	17	59	77	141	10
17	24	23	18	59	77	139	10
18	25	24	19	59	77	149	10
19	26.5	25	20	58	77	165	10
20	27.8	26	21	58	77	183	10
21	29	27	23	58	77	190	10
22	30	28	27	57	77	200	10
23	31.5	29	27	57	77	233	10
24	32.8	30	27	57	77	249	10
25	34	31	27	57	77	270	10
26	35	32	27	56	77	279	10
27	36.5	33	28	56	77	303	10
28	37.8	34	28	56	77	331	10
29	39	35	28	55	77	357	10
30	40	36	34	55	77	342	10
31	41.5	37	34	55	77	384	10
32	42.8	38	34	55	77	405	10
33	44.2	39	35	54	77	420	5
34	45.2	40	35	54	77	442	5
35	46.2	40	35	53	77	458	5
36	47.2	41	35	53	77	484	5
37	48.2	42	38	53	77	475	5
38	49	44	38	53	77	490	5

4305M / 4305A

12-point Deep Sockets
12-kant Steckschlüssel, lang
Douilles longues, 12-pans

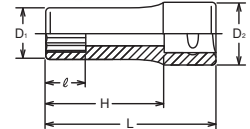

4300A 4305A (inch)	D ₁ (mm)	D ₂ (mm)	ℓ (mm)	H (mm)	L (mm)	(g)	(pcs.)
5/16	13.2	21	9	59	77	76	10
3/8	14.6	21	10	59	77	82	10
7/16	16.5	21	12	59	77	86	10
1/2	19	21.8	14	59	77	106	10
9/16	20.3	21.8	15	59	77	115	10
19/32	21.5	21.8	16	59	77	123	10
5/8	22.8	22	17	59	77	141	10
21/32	24	23	18	59	77	139	10
11/16	25	24	19	59	77	149	10
3/4	26.5	25	20	58	77	165	10
25/32	27.8	26	21	58	77	183	10
13/16	29	27	23	58	77	190	10
7/8	30	28	27	57	77	200	10
15/16	32.8	30	27	57	77	249	10
31/32	34	31	27	57	77	270	10
1	35	32	27	56	77	279	10
1. 1/16	36.5	33	28	56	77	303	10
1. 1/8	37.8	34	28	56	77	331	10
1. 3/16	40	36	34	55	77	342	10
1. 1/4	42.8	38	34	55	77	405	10
1. 5/16	44.2	39	35	54	77	420	5
1. 3/8	46.2	40	35	54	77	422	5
1. 7/16	47.2	41	35	53	77	484	5
1. 1/2	49	44	38	53	77	523	5
1.13/16	59	48	38	51	77	791	5

RS4300M/10



Socket Set on Rail
Steckschlüsselsatz auf Schiene
Jeu de douilles sur rail

RS4305M/10



RS4300M/12



Socket Set on Rail
Steckschlüsselsatz auf Schiene
Jeu de douilles sur rail



RS4300A/10



Socket Set on Rail
Steckschlüsselsatz auf Schiene
Jeu de douilles sur rail

RS4305A/10



RS4300M/10	10 Pieces Set/Rail 300mm	(g)
10, 11, 12, 13, 14, 15, 17, 19, 21, 22		1,415

RS4305M/10	10 Pieces Set/Rail 300mm	(g)
10, 11, 12, 13, 14, 15, 17, 19, 21, 22		1,415

RS4300M /12	12 Pieces Set/Rail 300mm	(g)
10, 12, 13, 14, 15, 16, 17, 18, 19, 20, 21, 22		1,825

RS4300A/10	10 Pieces Set/Rail 300mm	(g)
3/8, 7/16, 1/2, 9/16, 5/8, 11/16, 3/4, 13/16, 7/8, 15/16		1,600

RS4305A/10	10 Pieces Set/Rail 300mm	(g)
3/8, 7/16, 1/2, 9/16, 5/8, 11/16, 3/4, 13/16, 7/8, 15/16		1,600



Hand Sockets Hand Steckschlüssel Douilles à main

1/2"

Z-SERIES
HAND
TITANIUM
SCREWDRIVERS ACCESSORIES
IMPACT
SLEEVE-DRIVE
PROTECTOR
INDUSTRIAL
AUTOMOTIVE
MOTORCYCLE
CONSTRUCTION
SPARE PART

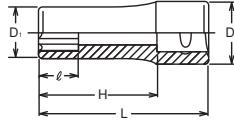
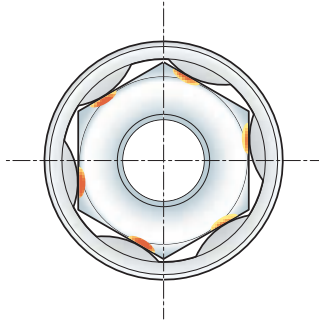
4310M Surface Drive Deep Sockets Surface Drive Steckschlüssel, lang Douilles longues, Surface Drive



4310M (mm)	D ₁ (mm)	D ₂ (mm)	ℓ (mm)	H (mm)	L (mm)	 (g)	 (pcs.)
8	13.2	21	9	59	77	79	10
9	13.8	21	10	59	77	82	10
10	15.3	21	11	59	77	82	10
11	16.5	21	12	59	77	86	10
12	17.8	21	13	59	77	92	10
13	19	21.8	14	59	77	106	10
14	20.3	21.8	15	59	77	115	10
15	21.5	21.8	16	59	77	123	10
16	22.8	22	17	59	77	141	10
17	24	23	18	59	77	139	10
18	25	24	19	59	77	149	10
19	26.5	25	20	58	77	165	10
20	27.8	26	21	58	77	183	10
21	29	27	23	58	77	190	10
22	30	28	27	57	77	200	10
23	31.5	29	27	57	77	233	10
24	32.8	30	27	57	77	249	10
25	34	31	27	57	77	270	10
26	35	32	27	56	77	279	10
27	36.5	33	28	56	77	303	10
28	37.8	34	28	56	77	334	10
29	39	35	28	55	77	357	10
30	40	36	34	55	77	342	10
31	41.5	37	34	55	77	384	10
32	42.8	38	34	55	77	405	10
34	45.2	40	35	54	77	442	5



RS4310M/10 Socket Set on Rail Steckschlüsselsatz auf Schiene Jeu de douilles sur rail

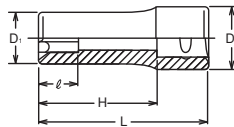

RS4310M/10	10 Pieces Set/Rail 300mm	 (g)
10, 11, 12, 13, 14, 15, 17, 19, 21, 22		1,415

4325 TORX® Deep Sockets TORX® Steckschlüssel, lang Douilles longues TORX®



4325 (E)	D ₁ (mm)	D ₂ (mm)	ℓ (mm)	H (mm)	L (mm)	 (g)	 (pcs.)
E 8	10.7	21	7	59	77	68	10
E10	13.2	21	8.2	59	77	99	10
E11	13.8	21	8.7	59	77	84	10
E12	14.6	21	9.3	59	77	99	10
E14	16.5	21	10.6	59	77	103	10
E16	19	21.8	11.8	59	77	107	10
E18	20.3	21.8	13	59	77	118	10
E20	22.8	22	14.4	59	77	141	10
New E22	25	24	15.5	59	77	188	10
E24	26.6	25	17	59	77	215	10

RS4325/7 Socket Set on Rail Steckschlüsselsatz auf Schiene Jeu de douilles sur rail



RS4325/7	7 Pieces Set/Rail 200mm	 (g)
E10, E12, E14, E16, E18, E20, E24		900

4300M(L120) (mm)	D ₁ (mm)	D ₂ (mm)	ℓ (mm)	H (mm)	L (mm)	(g)	(pcs.)
8	13.2	21	9	102	120	120	5
10	15.3	21	11	102	120	138	5
12	17.8	21	13	102	120	157	5
14	20.3	21.8	15	102	120	193	5
16	22.8	22	17	102	120	210	5

4300M (L120) 6-point Extra Deep Sockets 6-kant Steckschlüssel, extra lang Douilles extra longues 6-pans

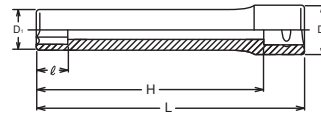

4325(L140)	D ₁ (mm)	D ₂ (mm)	ℓ (mm)	H (mm)	L (mm)	(g)	(pcs.)
E 8	10.7	21	7	122	140	110	5
E10	13.2	21	8.2	122	140	140	5
E12	14.6	21	9.3	122	140	160	5
E14	16.5	21	10.6	122	140	180	5

4325 (L140) TORX® Extra Deep Sockets TORX® Steckschlüssel, extra lang Douilles extra longues TORX®

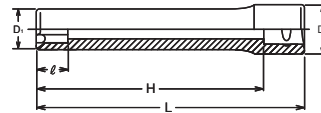

4325(L140) (2B)	D ₁ (mm)	D ₂ (mm)	ℓ (mm)	H (mm)	L (mm)	(g)	(pcs.)
E 8(2B)	10.7	21	6.6	122	140	110	5
E10(2B)	13.2	21	7.4	122	140	140	5
E12(2B)	14.6	21	9	122	140	160	5
E14(2B)	16.5	21	9.8	122	140	180	5

For Cylinder head bolt

4325 (L140)-2B TORX® Sockets Nut Grip® TORX Steckschlüssel mit 2-facher Kugelhalterung Douilles Torx à deux billes de retenue

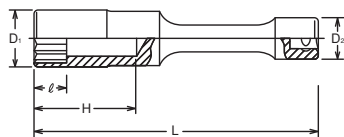
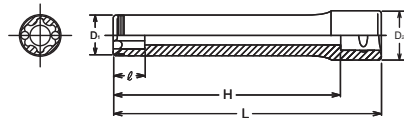

4117M-125/-250 Extended Sockets Schaftsteckschlüssel Douilles rallongées



4117M-125 (mm)	D ₁ (mm)	D ₂ (mm)	ℓ (mm)	H (mm)	L (mm)	(g)	(pce.)
13	18.7	24	13	59	125	213	1
14	20.2	24	14	59	125	227	1
17	24	24	17	59	125	274	1
19	26.9	24	19	59	125	279	1
21	28.5	24	21	59	125	291	1
22	30	24	22	59	125	323	1
24	32	24	24	59	125	361	1
27	36.5	24	27	59	125	439	1
30	40	24	30	59	125	461	1
32	42	24	32	59	125	498	1

4117M-250 (mm)	D ₁ (mm)	D ₂ (mm)	ℓ (mm)	H (mm)	L (mm)	(g)	(pce.)
13	18.7	24	13	59	250	412	1
14	20.2	24	14	59	250	423	1
17	24	24	17	59	250	469	1
19	26.9	24	19	59	250	484	1
21	28.5	24	21	59	250	496	1
22	30	24	22	59	250	516	1
24	32	24	24	59	250	560	1
27	36.5	24	27	59	250	641	1
30	40	24	30	59	250	663	1
32	42	24	32	59	250	698	1

Hand Sockets Hand Steckschlüssel Douilles à main

1/2"

Z-SERIES
HAND
TITANIUM
SCREWDRIVERS
ACCESSORIES
IMPACT
SLEEVE-DRIVE
PROTECTOR
INDUSTRIAL
AUTOMOTIVE
MOTORCYCLE
CONSTRUCTION
SPARE PART

4440M / 4440A 6-point Universal Sockets 6-kant Gelenk-Einsätze Douilles articulées, 6-pans

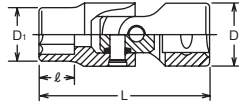

4440M (mm)	D ₁ (mm)	D ₂ (mm)	ℓ (mm)	L (mm)	(g)	(pcs.)
9	14	25	8.3	63	150	10
10	15.3	25	8.8	63	155	10
11	16.5	25	10	65	158	10
12	17.8	25	10.5	65	151	10
13	19	25	11.4	66	152	10
14	20.3	25	11.4	66	151	10
15	21.5	25	13	68	149	10
16	22.8	25	13	68	150	10
17	24	25	14	69	150	10
18	25.3	25	14	69	150	10
19	26.5	25	15	71	170	10
20	27.8	25	15	71	173	5
21	29	25	16	72	176	5
22	30.3	25	16	72	185	5

4440A (inch)	D ₁ (mm)	D ₂ (mm)	ℓ (mm)	L (mm)	(g)	(pcs.)
3/8	14.8	25	8.8	63	155	10
7/16	16.5	25	10	65	158	10
1/2	19	25	11.4	66	152	10
9/16	20.3	25	11.4	66	151	10
5/8	22.8	25	13	68	150	10
11/16	24.6	25	14	69	153	10
3/4	26.5	25	15	71	170	10
7/8	30.3	25	16	72	185	5

4440T TORX® Universal Sockets TORX® Gelenk-Einsätze Douilles articulées, TORX®

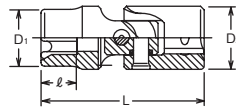

4440T (E)	D ₁ (mm)	D ₂ (mm)	ℓ (mm)	L (mm)	(g)	(pcs.)
E10	13.2	25	8.2	62	145	10
E12	15	25	9.3	63	147	10
E14	16.3	25	10.6	65	148	10
E16	18.8	25	11.8	65	150	10
E18	20.4	25	13	67	153	10

4000-60 (PH) Phillips Bit Sockets Steckschlüssel für Kreuzschlitzschrauben, Phillips Douilles tournevis pour vis à empreinte Phillips

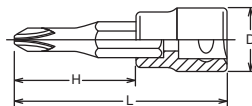

4000 (PH)	D (mm)	H (mm)	L (mm)	(g)	(pcs.)
2	22	23.5	60	65	10
3	22	23.5	60	65	10
4	22	23.5	60	67	10

4000-60 (PZ) PZ Bit Sockets Steckschlüssel für Kreuzschlitzschrauben, PZ Douilles tournevis pour vis à empreinte PZ

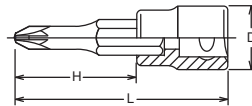

4000-60 (PZ)	D (mm)	H (mm)	L (mm)	(g)	(pcs.)
PZ2	22	23.5	60	65	10
PZ3	22	23.5	60	65	10

4005-60 Bit Sockets for Slotted Heads Steckschlüssel für Schlitzschrauben Douilles tournevis pour vis à fente

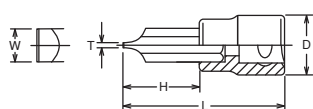



4005	T×W (mm)	D (mm)	H (mm)	L (mm)	(g)	(pcs.)
8	1.2× 8	22	23.5	60	65	10
10	1.6×10	22	23.5	60	75	10
12	2.0×12	23	23.5	60	111	10
14	2.5×14	24	23.5	60	133	10
16	2.5×16	24	23.5	60	133	10

1/2"

Hand Sockets
Hand Steckschlüssel
Douilles à main

4010M-50/-75/-100/-160 4010A-60

 Inhex Bit Sockets
Steckschlüssel für Innensechskant-Schrauben
 Douilles tournevis pour vis 6-pans creux



4010M-50 (mm)	D (mm)	H (mm)	L (mm)	(g)	(pcs.)
4	22	13.5	50	61	10
5	22	13.5	50	62	10
6	22	13.5	50	64	10
7	22	13.5	50	65	10
8	22	13.5	50	66	10
New 9	22	13.5	50	73	10
10	22	13.5	50	75	10
12	23	13.5	50	105	10
13	24	13.5	50	120	10
14	24	13.5	50	120	10
16	25	15	50	150	10
17	25	15	50	150	10
18	27	15	50	200	5
19	27	15	50	200	5

4010M-75 (mm)	D (mm)	H (mm)	L (mm)	(g)	(pcs.)
4	22	38.5	75	69	10
5	22	38.5	75	70	10
6	22	38.5	75	72	10
7	22	38.5	75	73	10
8	22	38.5	75	74	10
New 9	22	38.5	75	90	10
10	22	38.5	75	92	10
12	23	38.5	75	130	10
13	24	38.5	75	150	10
14	24	38.5	75	150	10
16	25	35	75	180	10
17	25	35	75	180	10
18	27	33	75	230	5
19	27	33	75	230	5

4010M-100 (mm)	D (mm)	H (mm)	L (mm)	(g)	(pcs.)
4	22	63.5	100	77	10
5	22	63.5	100	78	10
6	22	63.5	100	80	10
7	22	63.5	100	82	10
8	22	63.5	100	84	10
New 9	22	63.5	100	105	10
10	22	63.5	100	109	10
12	23	63.5	100	155	10
13	24	63.5	100	180	5
14	24	63.5	100	180	5
16	25	60	100	250	5
17	25	60	100	250	5
18	27	58	100	300	5
19	27	58	100	300	5

4010M-160 (mm)	D (mm)	H (mm)	L (mm)	(g)	(pcs.)
4	22	123.5	160	103	10
5	22	123.5	160	104	10
6	22	123.5	160	106	10
7	22	123.5	160	108	10
8	22	123.5	160	110	10
10	22	123.5	160	126	10
12	23	123.5	160	180	5
14	24	123.5	160	260	5
17	25	120	160	360	5
19	27	118	160	415	5



4010A-60 (inch)	D (mm)	H (mm)	L (mm)	(g)	(pcs.)
5/32	22	23.5	60	57	10
3/16	22	23.5	60	57	10
7/32	22	23.5	60	59	10
1/4	22	23.5	60	63	10
9/32	22	23.5	60	65	10
5/16	22	23.5	60	67	10
11/32	22	23.5	60	75	10
3/8	22	23.5	60	76	10
7/16	23	23.5	60	101	10
1/2	24	23.5	60	124	10
9/16	25	20	60	127	10
5/8	25	20	60	174	10
3/4	27	18	60	220	5



RS4010M/10-L50	10 Pieces Set/Rail 300mm	(g)
4, 5, 6, 7, 8, 10, 12, 14, 17, 19		968

RS4010M/10-L75	10 Pieces Set/Rail 300mm	(g)
4, 5, 6, 7, 8, 10, 12, 14, 17, 19		1,207

RS4010A/10-L60	10 Pieces Set/Rail 300mm	(g)
3/16, 7/32, 1/4, 5/16, 3/8, 7/16, 1/2, 9/16, 5/8, 3/4		1,080

RS4010M/10-L50  Socket Set on Rail
Steckschlüsselsatz auf Schiene
RS4010M/10-L75  Jeu de douilles sur rail
RS4010A/10-L60 



Hand Sockets Hand Steckschlüssel 1/2" Douilles à main

Z-SERIES
HAND
TITANIUM
SCREWDRIVERS ACCESSORIES
IMPACT
SLEEVE-DRIVE
PROTECTOR
INDUSTRIAL
AUTOMOTIVE
MOTORCYCLE
CONSTRUCTION
SPARE PART

4012M-43/-60/-75/-100



Inhex Sockets
Steckschlüssel für Innensechskant-Schrauben
Douilles tournevis pour vis 6-pans creux

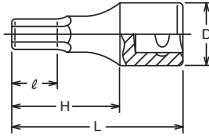

4012M-43 (mm)	D (mm)	ℓ (mm)	H (mm)	L (mm)	(g)	(pcs.)
4	21.1	11.5	23	43	40	10
5	21.1	11.5	23	43	46	10
6	21.1	11.5	23	43	42	10
7	21.1	11.5	23	43	46	10
8	21.1	11.5	23	43	49	10
9	21.1	11.5	23	43	63	10
10	23	11.5	23	43	63	10
11	25	11.5	23	43	74	10
12	25	11.5	23	43	81	10
13	25	11.5	23	43	85	10
14	25	11.5	23	43	88	10
15	26	11.5	23	43	91	10
16	26	11.5	23	43	100	10
17	26	11.5	23	43	101	10
18	26	11.5	23	43	106	10
19	26	11.5	23	43	110	10
20	26	11.5	23	43	130	10
21	26	11.5	23	43	140	10
22	26	11.5	23	43	145	10
23	28	11.5	23	43	167	10
24	28	11.5	23	43	170	10
27	32	11.5	23	43	226	10

4012M-60 (mm)	D (mm)	ℓ (mm)	H (mm)	L (mm)	(g)	(pcs.)
4	21.1	15.5	38	60	49	10
5	21.1	15.5	38	60	55	10
6	21.1	15.5	38	60	56	10
7	21.1	15.5	38	60	60	10
8	21.1	15.5	38	60	64	10
9	21.1	15.5	38	60	78	10
10	23	15.5	38	60	78	10
11	25	15.5	38	60	100	10
12	25	15.5	38	60	107	10
13	25	15.5	38	60	111	10
14	25	15.5	38	60	122	10
15	26	15.5	38	60	125	10
16	26	15.5	38	60	134	10
17	26	15.5	38	60	141	10
18	26	15.5	38	60	153	10
19	26	15.5	38	60	159	10
21	26	15.5	38	60	197	10
22	26	22.5	38	60	205	10
23	28	22.5	38	60	242	10
24	28	22.5	38	60	245	10

4012M-75 (mm)	D (mm)	ℓ (mm)	H (mm)	L (mm)	(g)	(pcs.)
4	21.1	15.5	53	75	52	10
5	21.1	15.5	53	75	58	10
6	21.1	15.5	53	75	62	10
7	21.1	15.5	53	75	70	10
8	21.1	15.5	53	75	74	10
9	21.1	15.5	53	75	88	10
10	23	15.5	53	75	94	10
11	25	15.5	53	75	119	10
12	25	15.5	53	75	122	10
13	25	15.5	53	75	137	10
14	25	15.5	53	75	148	10
15	26	15.5	53	75	151	10
16	26	15.5	53	75	171	10
17	26	15.5	53	75	184	10
18	26	15.5	53	75	196	10
19	26	15.5	53	75	212	10
New 22	26	22.5	53	75	266	10
New 24	27.9	22.5	53	75	315	10

4012M-100 (mm)	D (mm)	ℓ (mm)	H (mm)	L (mm)	(g)	(pcs.)
4	24	15.5	78	100	75	10
5	24	15.5	78	100	81	10
6	24	15.5	78	100	85	10
7	24	15.5	78	100	93	10
8	24	15.5	78	100	97	10
9	24	15.5	78	100	111	10
10	24	15.5	78	100	117	10
11	24	15.5	78	100	142	10
12	24	15.5	78	100	143	10
13	24	15.5	78	100	158	10
14	24	15.5	78	100	169	10
15	24	15.5	78	100	172	10
16	24	15.5	78	100	192	5
17	24	15.5	78	100	215	5
18	24	15.5	78	100	227	5
19	24	15.5	78	100	243	5

RS4012M/10-L60



Socket Set on Rail
Steckschlüsselsatz auf Schiene
Jeu de douilles sur rail



RS4012M/10-L60

10 Pieces set/Rail 300mm





4, 5, 6, 7, 8, 10, 12, 14, 17, 19

910



4012M/A are for hand use only.
Do not use with a power or impact wrench.
Nicht auf Maschinenschrauben verwenden.
À ne pas utiliser sur des machines

4012A-43/-60/-75/-100

 Inhex Sockets
Steckschlüssel für Innensechskant-Schrauben 
Douilles tournevis pour vis 6-pans creux

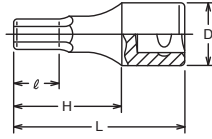

4012A-43 (inch)	D (mm)	ℓ (mm)	H (mm)	L (mm)	(g)	(pcs.)
5/32	21.1	11.5	23	43	40	10
3/16	21.1	11.5	23	43	46	10
7/32	21.1	11.5	23	43	42	10
1/4	21.1	11.5	23	43	43	10
9/32	21.1	11.5	23	43	46	10
5/16	21.1	11.5	23	43	49	10
11/32	21.1	11.5	23	43	63	10
3/8	23	11.5	23	43	59	10
7/16	25	11.5	23	43	74	10
1/2	25	11.5	23	43	85	10
9/16	25	11.5	23	43	88	10
5/8	26	11.5	23	43	100	10
3/4	26	11.5	23	43	110	10
New 7/8	26	11.5	23	43	141	10

4012A-60 (inch)	D (mm)	ℓ (mm)	H (mm)	L (mm)	(g)	(pcs.)
5/32	21.1	15.5	38	60	49	10
3/16	21.1	15.5	38	60	55	10
7/32	21.1	15.5	38	60	56	10
1/4	21.1	15.5	38	60	57	10
9/32	21.1	15.5	38	60	60	10
5/16	21.1	15.5	38	60	64	10
11/32	21.1	15.5	38	60	78	10
3/8	23	15.5	38	60	74	10
7/16	25	15.5	38	60	100	10
1/2	25	15.5	38	60	111	10
9/16	25	15.5	38	60	122	10
5/8	26	15.5	38	60	134	10
3/4	26	15.5	38	60	159	10
New 7/8	26	22.5	38	60	202	10

4012A-75 (inch)	D (mm)	ℓ (mm)	H (mm)	L (mm)	(g)	(pcs.)
5/32	21.1	15.5	53	75	52	10
3/16	21.1	15.5	53	75	58	10
7/32	21.1	15.5	53	75	62	10
1/4	21.1	15.5	53	75	65	10
9/32	21.1	15.5	53	75	70	10
5/16	21.1	15.5	53	75	74	10
11/32	21.1	15.5	53	75	88	10
3/8	23	15.5	53	75	86	10
7/16	25	15.5	53	75	119	10
1/2	25	15.5	53	75	137	10
9/16	25	15.5	53	75	148	10
5/8	26	15.5	53	75	171	10
3/4	26	15.5	53	75	212	10
New 7/8	26	22.5	53	75	262	10

4012A-100 (inch)	D (mm)	ℓ (mm)	H (mm)	L (mm)	(g)	(pcs.)
5/32	24	15.5	78	100	75	10
3/16	24	15.5	78	100	81	10
7/32	24	15.5	78	100	85	10
1/4	24	15.5	78	100	88	10
9/32	24	15.5	78	100	93	10
5/16	24	15.5	78	100	97	10
11/32	24	15.5	78	100	111	10
3/8	24	15.5	78	100	109	10
7/16	24	15.5	78	100	142	10
1/2	24	15.5	78	100	158	10
9/16	24	15.5	78	100	169	10
5/8	24	15.5	78	100	192	5
3/4	24	15.5	78	100	243	5

RS4012A/10-L60	10 Pieces set/Rail 300mm	(g)
3/16, 7/32, 1/4, 5/16, 3/8, 7/16, 1/2, 9/16, 5/8, 3/4		950

RS4012A/10-L60



Socket Set on Rail
Steckschlüsselsatz auf Schiene
Jeu de douilles sur rail



 4012M/A are for hand use only.
Do not use with a power or impact wrench.
Nicht auf Maschinenschrauben verwenden.
À ne pas utiliser sur des machines

Hand Sockets
Hand Steckschlüssel **1/2"**
Douilles à main

Z-SERIES
HAND
TITANIUM
SCREWDRIVERS ACCESSORIES
IMPACT
SLEEVE-DRIVE
PROTECTOR
INDUSTRIAL
AUTOMOTIVE
MOTORCYCLE
CONSTRUCTION
SPARE PART

4020-60/-100/-120/-140

 XZN Bit Sockets
Steckschlüssel für XZN Schrauben
Douilles tournevis pour empreinte XZN



4020-60 (XZN)	D (mm)	H (mm)	L (mm)	(g)	(pcs.)
M 5	22	23.5	60	60	10
M 6	22	23.5	60	61	10
M 8	22	23.5	60	63	10
M10	23	23.5	60	93	10
M12	23	23.5	60	97	10
M14	24	23.5	60	105	10
M16	25	20	60	165	10
M18	27	20	60	215	5

4020-100 (XZN)	D (mm)	H (mm)	L (mm)	(g)	(pcs.)
M 5	22	63.5	100	77	10
M 6	22	63.5	100	78	10
M 8	22	63.5	100	80	10
M10	23	63.5	100	132	10
M12	23	63.5	100	136	10
M14	24	63.5	100	144	5
M16	25	60	100	250	5
M18	27	60	100	300	5

4020-120 (XZN)	D (mm)	H (mm)	L (mm)	(g)	(pcs.)
M 5	22	83.5	120	86	10
M 6	22	83.5	120	87	10
M 8	22	83.5	120	89	10
M10	23	83.5	120	152	10
M12	23	83.5	120	156	10
M14	24	83.5	120	164	5

4020-140 (XZN)	D (mm)	H (mm)	L (mm)	(g)	(pcs.)
M 5	22	103.5	140	95	10
M 6	22	103.5	140	96	10
M 8	22	103.5	140	98	10
M10	23	103.5	140	172	5
M12	23	103.5	140	176	5
M14	24	103.5	140	184	5

XZN

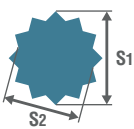

XZN		M4	M5	M6	M8	M10	M12	M14	M16	M18
S ₁	(ref. mm)	3.6	4.8	6.1	7.3	9.7	11.5	13.3	15.7	16.9
S ₂	(ref. mm)	3.1	4.1	5.1	6.1	8.1	9.7	11.2	13.2	14.2

RS4020/6-L60
RS4020/6-L100

 Socket Set on Rail
Steckschlüsselsatz auf Schiene
Jeu de douilles sur rail



RS4020/6-L60	6 Pieces Set/Rail 150mm	(g)
M5, M6, M8, M10, M12, M14		500
RS4020/6-L100	6 Pieces Set/Rail 150mm	(g)
M5, M6, M8, M10, M12, M14		680

1/2"

Hand Sockets
Hand Steckschlüssel
Douilles à main

Z-SERIES
HAND
TITANIUM
ACCESSORIES
SCREWDRIVERS
IMPACT
SLEEVE-DRIVE
PROTECTOR
INDUSTRIAL
AUTOMOTIVE
MOTORCYCLE
CONSTRUCTION
SPARE PART

4025-60 (T)	D (mm)	H (mm)	L (mm)	(g)	(pcs.)
T15	22	23.5	60	58	10
T20	22	23.5	60	59	10
T25	22	23.5	60	60	10
T27	22	23.5	60	60	10
T30	22	23.5	60	60	10
T40	22	23.5	60	62	10
T45	22	23.5	60	64	10
T50	22	23.5	60	74	10
T55	23	23.5	60	96	10
T60	24	23.5	60	122	10
T70	24	23.5	60	135	10
T80	24	20	60	168	10

4025-100 (T)	D (mm)	H (mm)	L (mm)	(g)	(pcs.)
T20	22	73.5	100	76	10
T25	22	73.5	100	76	10
T27	22	73.5	100	77	10
T30	22	73.5	100	77	10
T40	22	73.5	100	78	10
T45	22	73.5	100	80	10
T50	22	73.5	100	98	10
T55	23	73.5	100	132	10
T60	24	73.5	100	170	5
T70	24	73.5	100	175	5

RS4025/9-L60	9 Pieces Set/Rail 250mm	(g)
T20, T25, T27, T30, T40, T45, T50, T55, T60		700

4025-60/-100/-140 (T)

TORX® Bit Sockets
TORX® Bit-Steckschlüssel
Douilles tournevis, TORX®

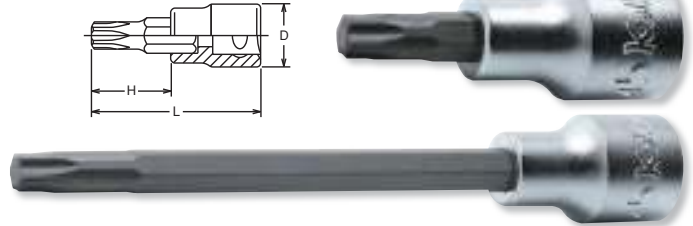

4025-140 (T)	D (mm)	H (mm)	L (mm)	(g)	(pcs.)
T20	22	103.5	140	94	10
T25	22	103.5	140	95	10
T27	22	103.5	140	95	10
T30	22	103.5	140	95	10
T40	22	103.5	140	97	10
T45	22	103.5	140	99	10
T50	22	103.5	140	129	10
T55	23	103.5	140	175	5
T60	24	103.5	140	229	5
T70	24	103.5	140	245	5
T80	24	100	140	320	5

RS4025/9-L60



Socket Set on Rail
Steckschlüsselsatz auf Schiene
Jeu de douilles sur rail



TORX® (T)

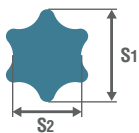

T	T8	T9	T10	T15	T20	T25	T27	T30	T40	T45	T50	T55	T60	T70	T80	T90	T100
S ₁ (ref. mm)	2.3	2.5	2.7	3.3	3.9	4.5	5.0	5.6	6.7	7.9	8.9	11.3	13.3	15.6	17.6	20.0	22.2
S ₂ (ref. mm)	1.7	1.8	2.0	2.3	2.8	3.2	3.6	4.0	4.8	5.6	6.2	8.0	9.5	11.1	12.7	14.2	15.8

4025-60 (IP)	D (mm)	H (mm)	L (mm)	(g)	(pcs.)
20IP	22	23.5	60	60	10
25IP	22	23.5	60	60	10
27IP	22	23.5	60	60	10
30IP	22	23.5	60	60	10
40IP	22	23.5	60	60	10
45IP	22	23.5	60	64	10
50IP	22	23.5	60	74	10
55IP	23	23.5	60	96	10
60IP	24	23.5	60	122	10
70IP	24	23.5	60	170	10

4025-100 (IP)	D (mm)	H (mm)	L (mm)	(g)	(pcs.)
40IP	22	63.5	100	79	10
45IP	22	63.5	100	81	10
50IP	22	63.5	100	100	10
55IP	23	63.5	100	133	10
60IP	24	63.5	100	172	5
70IP	25	63.5	100	241	5

RS4025/9-IP	9 Pieces set/Rail 250mm	(g)
20IP, 25IP, 27IP, 30IP, 40IP, 45IP, 50IP, 55IP, 60IP		700

4025-60/-100 (IP)



TORXPLUS® Bit Sockets
TORXPLUS® Bit-Steckschlüssel
Douilles tournevis, TORXPLUS®

TORXplus

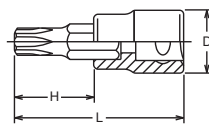

RS4025/9-IP



Socket Set on Rail
Steckschlüsselsatz auf Schiene
Jeu de douilles sur rail



TORXPLUS® (IP)

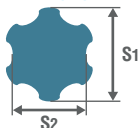

IP	8IP	9IP	10IP	15IP	20IP	25IP	27IP	30IP	40IP	45IP	50IP	55IP	60IP	70IP
S ₁ (ref. mm)	2.3	2.5	2.7	3.3	3.9	4.5	5.0	5.6	6.7	7.9	8.9	11.3	13.3	15.6
S ₂ (ref. mm)	1.7	1.8	2.0	2.3	2.8	3.2	3.6	4.0	4.8	5.6	6.2	8.0	9.5	11.1

TORX® is a registered trademark of Acument Intellectual Properties, LLC.
TORX® ist ein registriertes Markenzeichen der Firma Acument Intellectual Properties, LLC.
TORX® est une marque déposée de Acument Intellectual Properties, LLC.

TORXplus® is a registered trademark of Acument Intellectual Properties, LLC.
TORXplus® ist ein registriertes Markenzeichen der Firma Acument Intellectual Properties, LLC.
TORXplus® est une marque déposée de Acument Intellectual Properties, LLC.

Hand Sockets Hand Steckschlüssel Douilles à main

1/2"

Z-SERIES
HAND
TITANIUM
SCREWDRIVERS ACCESSORIES
IMPACT
SLEEVE-DRIVE
PROTECTOR
INDUSTRIAL
AUTOMOTIVE
MOTORCYCLE
CONSTRUCTION
SPARE PART

4025-60-T35

Bit Socket
Bit-Steckschlüssel
Douille tournevis



4025-60 (T)	D (mm)	H (mm)	L (mm)	(g)	(pcs.)
T35	22	23.5	60	96	10

For T35 Special screws

4027-60/-100/-140

Bit Sockets for Ribe Screws
Steckschlüsselklingen für Ribe Schrauben
Douilles tournevis pour écrous profil Ribe

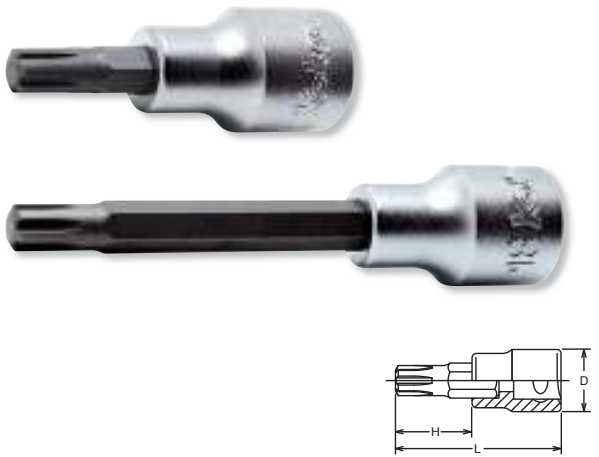

4027-60	D (mm)	H (mm)	L (mm)	(g)	(pcs.)
M 5	22	23.5	60	60	10
M 6	22	23.5	60	62	10
M 7	22	23.5	60	63	10
M 8	22	23.5	60	64	10
M 9	22	23.5	60	70	10
M10	22	23.5	60	74	10
M12	23	23.5	60	96	10
M13	24	23.5	60	116	10
M14	24	23.5	60	122	10
M16	24	25	60	135	10

4027-100	D (mm)	H (mm)	L (mm)	(g)	(pcs.)
M 5	22	63.5	100	67	10
M 6	22	63.5	100	68	10
M 7	22	63.5	100	75	10
M 8	22	63.5	100	81	10
M 9	22	63.5	100	90	10
M10	22	63.5	100	101	10
M12	23	63.5	100	134	10
M13	24	63.5	100	155	5
M14	24	63.5	100	173	5
M16	24	60	100	241	5

4027-140	D (mm)	H (mm)	L (mm)	(g)	(pcs.)
M 8	22	103.5	140	98	10
M10	22	103.5	140	127	10
M12	23	103.5	140	171	5
M14	24	103.5	140	226	5
M16	24	100	140	320	5

Ribe CV

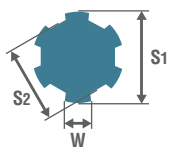

CV		M5	M6	M7	M8	M9	M10	M12	M13	M14	M16
W	(ref. mm)	1.2	1.3	1.4	1.8	2.0	2.3	2.6	3.1	3.2	3.6
S ₁	(ref. mm)	5.0	6.0	7.0	8.0	9.0	10.0	12.0	13.0	14.0	16.0
S ₂	(ref. mm)	3.8	4.5	5.0	6.0	7.1	7.4	9.0	11.0	10.4	11.9

RS4027/7-L60

Socket Set on Rail
Steckschlüsselsatz auf Schiene
Jeu de douilles sur rail



RS4027/7-L60	7 Pieces set/Rail 200mm	(g)
M5, M6, M8, M10, M12, M14, M16		600

4101	T×W (mm)	D (mm)	L (mm)	(g)	(pcs.)
1	2.7×18.6	22	40	59	10
2	3.7×24	24	40	79	10
3	3.7×30	30	40	128	10

4101  Sockets for Slotted Heads
Steckschlüssel für Schlitzschrauben
Douilles tournevis pour vis à fente

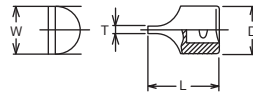

4137	D ₁ (mm)	D ₂ (mm)	L (mm)	(g)	(pcs.)
4137	13	22	38	53	10

4137  Bit Holder
Klingenhalter
Porte-embouts

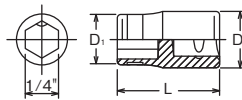

For DIN3126 C6.3 Bits
Für DIN3126 C6.3 Bits
Pour DIN3126 C6.3 Embouts

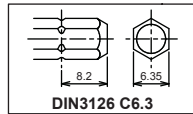

DIN3126 C6.3

4138	D ₁ (mm)	D ₂ (mm)	L (mm)	(g)	(pcs.)
4138	16	22	38	62	10

4138  Bit Holder
Klingenhalter
Porte-embouts

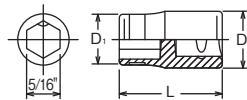

For DIN3126 C8 Bits
Für DIN3126 C8 Bits
Pour DIN3126 C8 Embouts

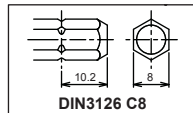

DIN3126 C8

4141	D ₁ (mm)	D ₂ (mm)	L (mm)	(g)	(pcs.)
4141	16	22	52	70	10

4141  Bit Holder, extra deep for 131P-80, 131S-80, 131T-80
Klingenhalter, extra tief für 131P-80, 131S-80, 131T-80
Porte embout, ouverture longue pour 131P-80, 131S-80, 131T-80

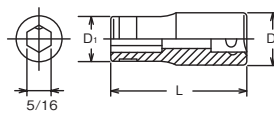

Hand Sockets Hand Steckschlüssel Douilles à main

1/2"

Z-SERIES
HAND
TITANIUM
SCREWDRIVERS ACCESSORIES
IMPACT
SLEEVE-DRIVE
PROTECTOR
INDUSTRIAL
AUTOMOTIVE
MOTORCYCLE
CONSTRUCTION
SPARE PART

3749S-1/2 Reversible Ratchet Short
Knarre, verstellbar
Cliquet, réversible



* Renewal Kits → 3749SRK-1/2 → P299

3749SB-1/2 Reversible Ratchet short with quick release button
Knarre, verstellbar mit Verriegelungsknopf
Cliquet, réversible avec bouton de débrayage

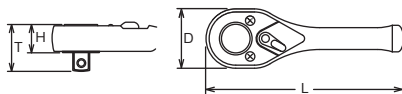

* Renewal Kits → 3749SRK-1/2 → P299

	D (mm)	T (mm)	H (mm)	L (mm)	(g)	(pcs.)
3749S-1/2	34	29	14.4	110	200	5
3749SB-1/2	34	29	14.4	110	200	5

⚠ Reversible Ratchet with quick release button has less strength compared with normal ratchet due to the technical design. Make sure to use the ratchet correctly.

4752J Reversible Ratchet
Knarre, verstellbar
Cliquet, réversible



* Renewal Kits → 4752RK → P299

[L/R Marking]



A pointer and L/R markings on the ratchet head indicate the turning direction. The reduced diameter of the head allows easier access in tight spots.

Eine L/R Markierung auf dem Knarrenkopf zeigt die gerade eingestellte Drehrichtung an. Der geringe Kopfdurchmesser erleichtert das Arbeiten auch an schwer zugänglichen Stellen.

Un marquage L/R sur la tête de cliquet indique le sens de rotation. Le diamètre de tête réduit et facilite le travail dans les endroits difficilement accessibles.

4752N Reversible Ratchet
Knarre, verstellbar
Cliquet, réversible

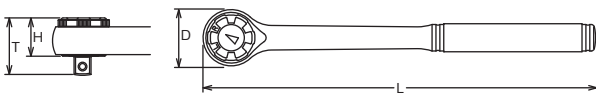

	D (mm)	T (mm)	H (mm)	L (mm)	(g)	(pcs.)
4752J	35	38.8	24.5	250	470	1
4752N	35	38.8	24.5	250	480	1

GEAR TEETH



4749series



4753series



4750series



4752series



4774series





* Renewal Kits → 4750RK → P299

4750J Reversible Ratchet
Knarre, verstellbar
Cliquet, réversible



* Renewal Kits → 4750RK → P299

4750P Reversible Ratchet
Knarre, verstellbar
Cliquet, réversible



* Renewal Kits → 4750RK → P299

4750N Reversible Ratchet
Knarre, verstellbar
Cliquet, réversible



	D (mm)	T (mm)	H (mm)	L (mm)	(g)	(pce.)
4750J	38	35.9	21.3	250	508	1
4750P	38	35.9	21.3	250	553	1
4750N	38	35.9	21.3	250	548	1

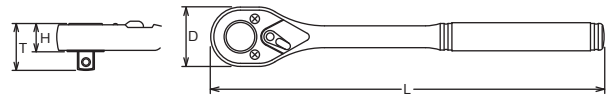

* Renewal Kits → 4750BRK → P299

4750JB Reversible Ratchet with quick release button
Knarre, verstellbar mit Verriegelungsknopf
4750PB Cliquet, réversible avec bouton de débrayage ⚠
4750NB



	D (mm)	T (mm)	H (mm)	L (mm)	(g)	(pce.)
4750JB	38	35.9	21.3	250	508	1
4750PB	38	35.9	21.3	250	553	1
4750NB	38	35.9	21.3	250	548	1

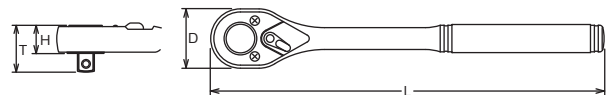

⚠ Reversible Ratchet with quick release button has less strength compared with normal ratchet due to the technical design. Make sure to use the ratchet correctly.

[4750 series]



Two dogs are set in the same axis and the three teeth hold the ratchet gear. The enlarged contact area produces an about 10% higher torque value and the S.O.D.H system provides smooth and light movements.

Die scharnierartig eingelagerten Sperrklinken haben jetzt jeweils drei Zähne im Eingriff. Die dadurch vergrößerte Greiffläche erhöht das maximale Drehmoment um ca. 10%. Auch diese Knarre besticht durch ihren leichten und geschmeidigen Lauf.

Les deux rochets étant placés sur le même axe, les trois dents de l'engrenage sont engagées en permanence. Ce système assure une augmentation de 10% du couple maximum admissible. Ce cliquet se caractérise également par son fonctionnement souple et sans à-coup.

Hand Sockets Hand Steckschlüssel Douilles à main

1/2"

Z-SERIES
HAND
TITANIUM
SCREWDRIVERS ACCESSORIES
IMPACT
SLEEVE-DRIVE
PROTECTOR
INDUSTRIAL
AUTOMOTIVE
MOTORCYCLE
CONSTRUCTION
SPARE PART

4753J Reversible Ratchet
Knarre, verstellbar
Cliquet, réversible



* Renewal Kits → **4753RK** → P299

4753P Reversible Ratchet
Knarre, verstellbar
Cliquet, réversible



* Renewal Kits → **4753RK** → P299

4753N Reversible Ratchet
Knarre, verstellbar
Cliquet, réversible



* Renewal Kits → **4753RK** → P299

D4753J Reversible Ratchet
Knarre, verstellbar
Cliquet, réversible



* Renewal Kits → **4753RK** → P299

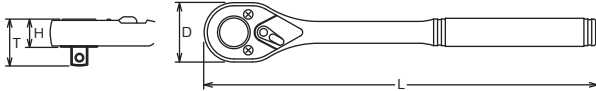

	D (mm)	T (mm)	H (mm)	L (mm)	(g)	(pce.)
4753J	38	36.2	21.6	250	545	1
4753P	38	36.2	21.6	250	570	1
4753N	38	36.2	21.6	250	595	1
D4753J	38	36.2	21.6	250	510	1

4753JB Reversible Ratchet with quick release button
4753PB Knarre, verstellbar mit Verriegelungsknopf
4753NB Cliquet, réversible avec bouton de débrayage



* Renewal Kits → **4753BRK** → P299

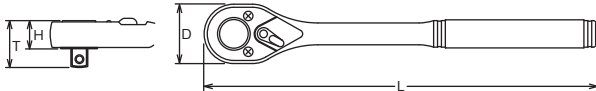

	D (mm)	T (mm)	H (mm)	L (mm)	(g)	(pce.)
4753JB	38	36.2	21.6	250	545	1
4753PB	38	36.2	21.6	250	570	1
4753NB	38	36.2	21.6	250	595	1

Reversible Ratchet with quick release button has less strength compared with normal ratchet due to the technical design. Make sure to use the ratchet correctly.



Reversible Ratchet with Quick Release Button :
Sockets and accessories are safely locked. By pushing the button the sockets or extension bars are released from the ratchet.

Umstellbare Knarre mit Verriegelungsknopf :
Steckschlüssel und Zubehörteile werden sicher und fest gehalten. Bei Drücken des Knopfes lösen sich die Teile.

Cliquet réversible à verrouillage :
Les douilles et accessoires ne peuvent plus tomber. Une pression du pouce sur le bouton suffit pour les libérer.



* Renewal Kits → 4749RK → P299

4749J-380 Reversible Ratchet (long)
4749N-380 Verstellbare Knarre, lang
Cliquet réversible, long



	D (mm)	T (mm)	H (mm)	L (mm)	(g)	(pce.)
4749J-380	44.6	33	18.4	380	743	1
4749N-380	44.6	33	18.4	380	753	1

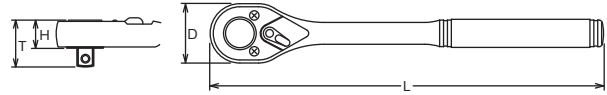

* Renewal Kits → 4753RK → P299

4753P-410 Reversible Ratchet (long)
Verstellbare Knarre, lang
Cliquet réversible, long



	D (mm)	T (mm)	H (mm)	L (mm)	(g)	(pce.)
4753P-410	38	36.2	21.6	410	790	1

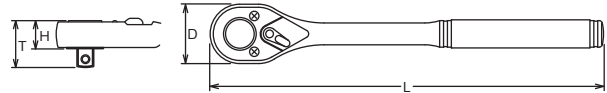

* Renewal Kits → 4753RK → P299

4774J Flexible Ratchet, reversible
4774P Gelenk-Knarre, verstellbar
4774N Cliquet, articulé, réversible

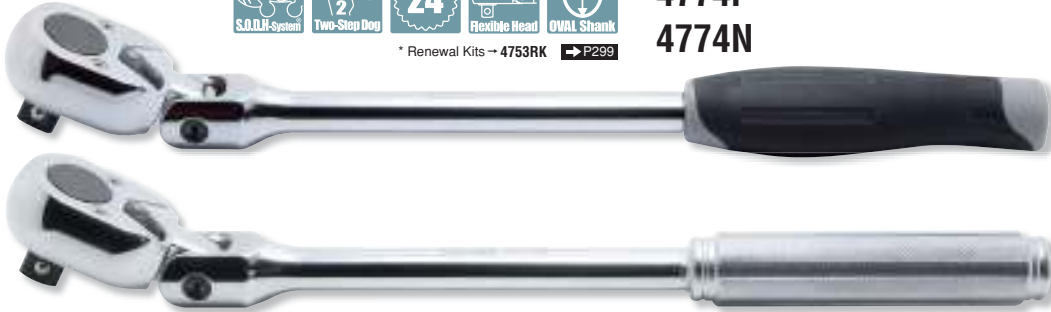

	D (mm)	T (mm)	H (mm)	L (mm)	(g)	(pce.)
4774J	38	36.2	21.6	330	685	1
4774P	38	36.2	21.6	330	700	1
4774N	38	36.2	21.6	330	700	1

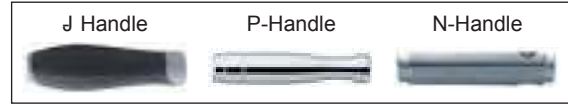
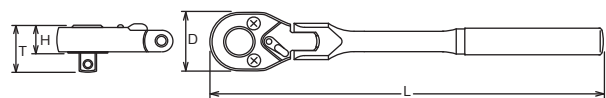

* Renewal Kits → 4753RK → P299

4774P-450 Flexible Ratchet, reversible ⚠
Gelenk-Knarre, verstellbar
Cliquet, articulé, réversible



	D (mm)	T (mm)	H (mm)	L (mm)	(g)	(pce.)
4774P-450	38	36.2	21.6	450	790	1

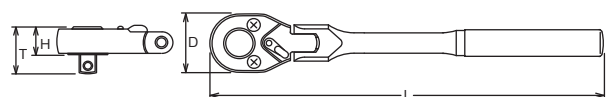

⚠ 4774P-450 has longer handle than standard, and can be loaded to excessive torque value. In the interest of your own safety always apply load evenly and progressively to avoid breakage and possible injury.

Hand Sockets
Hand Steckschlüssel
Douilles à main

1/2"

Z-SERIES
HAND
TITANIUM
SCREWDRIVERS
ACCESSORIES
IMPACT
SLEEVE-DRIVE
PROTECTOR
INDUSTRIAL
AUTOMOTIVE
MOTORCYCLE
CONSTRUCTION
SPARE PART

4774JB Flexible Ratchet, reversible with quick release button 
4774PB Gelenk-Knarre, verstellbar mit Verriegelungsknopf
4774NB Cliquet, articulé, réversible avec bouton de débrayage



* Renewal Kits → **4753BRK** → **P299**

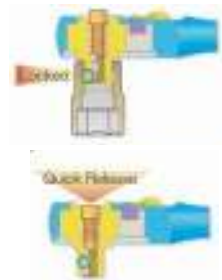
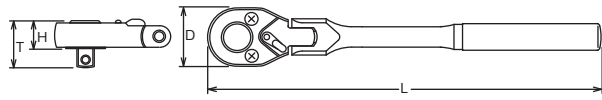

	D (mm)	T (mm)	H (mm)	L (mm)	(g)	(pcs.)
4774JB	38	36.2	21.6	330	685	1
4774PB	38	36.2	21.6	330	700	1
4774NB	38	36.2	21.6	330	700	1

 Reversible Ratchet with quick release button has less strength compared with normal ratchet due to the technical design. Make sure to use the ratchet correctly.

Reversible Ratchet with Quick Release Button :
Sockets and accessories are safely locked. By pushing the button the sockets or extension bars are released from the ratchet.

Umstellbare Knarre mit Verriegelungsknopf :
Steckschlüssel und Zubehörteile werden sicher und fest gehalten. Bei Drücken des Knopfes lösen sich die Teile.

Cliquet réversible à verrouillage :
Les douilles et accessoires ne peuvent plus se libérer. Une pression du pouce sur le bouton suffit pour les extraire.

4755 Ratchet Adaptor
Aufsteckknarre
Cliquet adaptable



45

* Renewal Kits → **4755RK** → **P300**

	D (mm)	L (mm)	(g)	(pcs.)
4755	33.5	65	270	5

4756 Quick Spinner
Rändel-Drehscheibe
Lanceur



	D (mm)	L (mm)	(g)	(pcs.)
4756	38	34.5	95	10

4768J-380/-450 Hinge Handles
Gelenkgriffe
Poignées articulées 



* Renewal Kits → **4768RK** → **P300**



4768P-380/-450 Hinge Handles
Gelenkgriffe
Poignées articulées 



* Renewal Kits → **4768RK** → **P300**

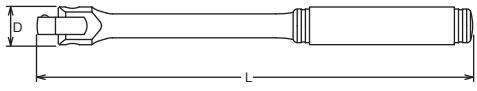

 4768-450 has longer handle than standard, and can be loaded to excessive torque value. Please use carefully.

	D (mm)	L (mm)	(g)	(pcs.)
4768J-380	28	380	600	1
4768J-450	28	450	690	1
4768P-380	28	380	665	2
4768P-450	28	450	748	2

4760	D (mm)	L (mm)	(g)	(pcs.)
50	24	50	92	10
75	24	75	138	10
100	24	100	158	5
125	24	125	194	5
150	24	150	266	5
200	24	200	295	5
250	24	250	358	5
300	24	300	492	2
400	24	400	650	1
500	24	500	808	1
600	24	600	968	1
900	24	900	1430	1
1000	24	1000	1593	1

PK4760/5 5 Pieces Set/△=1,050g
PLASTIC TRAY

Extension Bars

4760 Extension Bars
50, 75, 125, 150, 250

Rotation and general handling of extensions with oily hands is greatly improved with the **Kokon** developed 6 point knurling. Also the **Kokon** 6 point knurling stops the extensions from rolling around the work area.

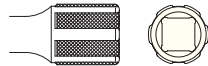

Durch die von **Kokon** entwickelte 6 fache Rändelung wird die Handhabung deutlich erleichtert. Außerdem wird das Herumrollen der Verlängerungen wirksam verhindert.

La manipulation des rallonges est grandement facilitée par le profil moleté développé par **Kokon**. Ce même profil empêche le roulement intempestif des rallonges sur le plan de travail.

4763	D (mm)	L (mm)	(g)	(pcs.)
50	24	50	95	10
75	24	75	111	10
125	24	125	157	5
150	24	150	181	5
250	24	250	357	5
400	24	400	650	1

⚠ The Wobble-Fix Extension Bar has less strength than normal extension bar due to it's specific design with a reduced square drive. Make sure to use it correctly.



PK4763/5 5 Pieces Set/△=950g
PLASTIC TRAY

Extension Bars

4763 Wobble-Fix Extension Bars
50, 75, 125, 150, 250

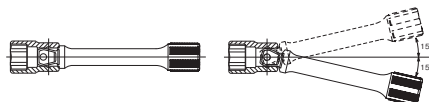

Wobble-Fix Extension Bar

Two way usage

- In a fixed position, as a normal extension bar
- In a half-fixed position, as a flexible extension bar providing a 15° angle operation

Winkel-Verlängerungen

Winkelverlängerungen lassen sich in zwei Einstellungen verwenden

- voll eingesteckt und starr,
- halb eingesteckt, mit einem Arbeitswinkel von 15°.

Rallonges angulaires

Deux utilisations possibles

- comme rallonge normale, dans une position fixe
- comme une rallonge angulaire avec une possibilité d'inclinaison jusqu'à 15°

4760-50/-75/-100/-125/-150/-200/-250/ -300/-400/-500/-600/-900/-1000

Extension Bars
Verlängerungen
Rallonges

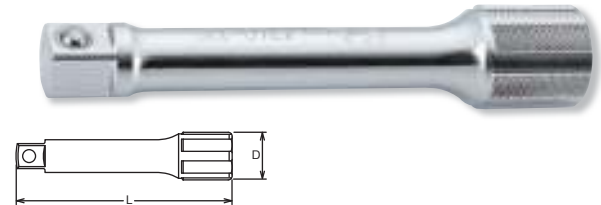

PK4760/5

Extension Bars in Plastic Box
Verlängerungen in Kunststoff-Kassette
Rallonges en boîte plastique



4763-50/-75/-125/-150/-250/-400

Wobble-Fix Extension Bars
Winkel-Verlängerungen
Rallonges angulaires

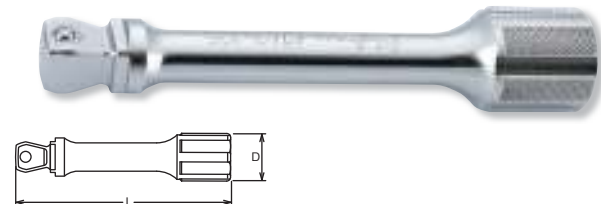

PK4763/5

Wobble-Fix Extension Bars in Plastic Box
Winkel Verlängerungen in Kunststoff-Kassette
Rallonges angulaires en boîte plastique



Hand Sockets
Hand Steckschlüssel
Douilles à main

1/2"

Z-SERIES
HAND
TITANIUM
SCREWDRIVERS ACCESSORIES
IMPACT
SLEEVE-DRIVE
PROTECTOR
INDUSTRIAL
AUTOMOTIVE
MOTORCYCLE
CONSTRUCTION
SPARE PART

4770 Universal Joint
Gelenk-Einsatz
Cardan universel

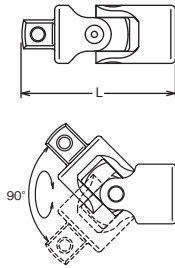

	L (mm)	(g)	(pcs.)
4770	62.4	150	10

4771 Universal Joint
Gelenk-Einsatz
Joint articlé

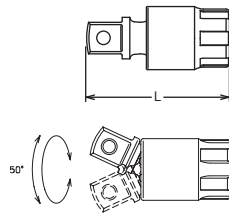

	L (mm)	(g)	(pcs.)
4771	57.7	113	10

4780-400 Speed Handle
Winde
Vilebrequin

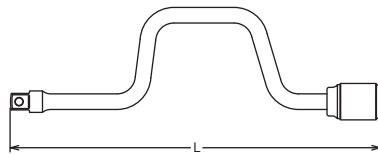

	L (mm)	(g)	(pce.)
4780	400	644	1

4781N-450 Flexible Speed Handle
Gelenkgriff-Winde
Vilebrequin

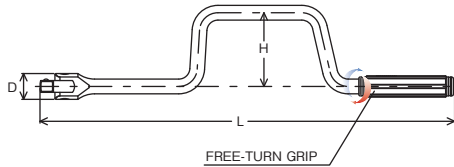

* Renewal Kits → 4768RK → P300

	D (mm)	H (mm)	L (mm)	(g)	(pce.)
4781N-450	28	80	450	1000	1

4785 T-Handle
T-Griff
Poignée coulissante

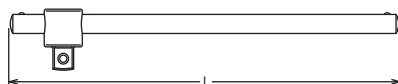

	L (mm)	(g)	(pcs.)
4785	300	410	2



1/2"

Hand Sockets
Hand Steckschlüssel
Douilles à main



4747 L-Handle
L-Griff
Poignées en L



	L ₁ (mm)	L ₂ (mm)	(g)	(pcs.)
4747	260	50	470	1

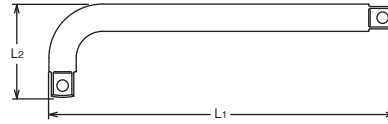

4788-250/-300/-450 L-Handles
L-Griffe
Poignées en L



4788	L ₁ (mm)	L ₂ (mm)	(g)	(pcs.)
250	250	53	417	2
300	300	53	503	1
450	450	53	745	1

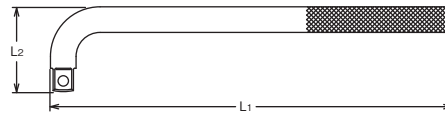

4433A	□ (sq.)	□ (sq.)	L (mm)	(g)	(pcs.)
35	1/2"	3/8"	35	50	10
75	1/2"	3/8"	75	120	10
125	1/2"	3/8"	125	164	5
250	1/2"	3/8"	250	275	5
600	1/2"	3/8"	600	530	1

Items in this catalogue marked can be loaded to torque values which may cause breakage.
In the interest of your own safety always apply load evenly and progressively to avoid breakage and possible injury.

Die mit gekennzeichneten Artikel können bei Überbelastungen zu Bruch gehen. Aus Gründen Ihrer Sicherheit, sollten die betreffenden Werkzeuge nie ruckartig sondern nach und nach belastet werden, um Bruch und damit verbundene, mögliche Verletzungen zu vermeiden.

Il est possible d'appliquer aux articles marqués des couples de serrage susceptibles d'occasionner leur rupture. Pour votre propre sécurité, veuillez toujours appliquer la charge d'une manière uniforme et progressive. Ceci pour éviter ruptures et accidents.

4433A-35/-75/-125/-250/-600

Adaptors
Verbindungsstücke
Réducteurs

Warranty 290Nm
Garantie 290Nm
Garantie 290Nm

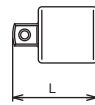

4466A Adaptor
Verbindungsstück
Réducteurs

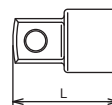

	□ (sq.)	□ (sq.)	L (mm)	(g)	(pcs.)
4466A	1/2"	3/4"	42	108	10

Z-SERIES
HAND
TITANIUM
ACCESSORIES
SCREWDRIVERS
IMPACT
SLEEVE-DRIVE
PROTECTOR
INDUSTRIAL
AUTOMOTIVE
MOTORCYCLE
CONSTRUCTION
SPARE PART

Hand Sockets
Hand Steckschlüssel
Douilles à main **1/2"**

Z-SERIES
HAND
TITANIUM
SCREWDRIVERS
ACCESSORIES
IMPACT
SLEEVE-DRIVE
PROTECTOR
INDUSTRIAL
AUTOMOTIVE
MOTORCYCLE
CONSTRUCTION
SPARE PART

4223M-01 Socket Sets
Steckschlüssel Sätze
4223M-06 Jeux de clés à douilles



4223M-01 15 Pieces Set/⚖️=2,600g
4223M-06 15 Pieces Set/⚖️=2,600g

METAL CASE:W415xH120xT50mm

Sockets		Accessories	
(4223M-01) 4401M 6-pt. Sockets 10, 11, 12, 13, 14, 15, 16, 17, 18, 19, 21, 22			4753J
(4223M-06) 4406M 12-pt. Sockets 10, 11, 12, 13, 14, 15, 16, 17, 18, 19, 21, 22			4760-125
			4770

4238AM Socket Sets
Steckschlüssel Sätze
Jeux de clés à douilles



4238AM 38 Pieces Set/⚖️=8,050g

METAL CASE:W446xH266xT50mm

Sockets		Accessories	
4405M 12-pt. Sockets 10, 11, 12, 13, 14, 15, 16, 17, 18, 19, 21, 22, 23, 24, 26, 27, 30, 32			4753N
4405A 12-pt. Sockets 3/8, 7/16, 1/2, 9/16, 5/8, 11/16, 3/4, 13/16, 7/8, 15/16, 1.1/16, 1.1/8, 1.1/4			4760-125
4300C Spark Plug Socket 20.8			4760-250
			4770
			4780
			4785

S4240M-01 Display Stands
S4240A-00 Ausstellungsstände
S4240M-06 Présentoirs
S4240A-05



S4240M-01 4401M 117 Pieces Set/⚖️=13,000g
S4240M-06 4406M 117 Pieces Set/⚖️=13,000g

DISPLAY STAND:W510xH150xT230mm

Sockets		
10mm:9pcs	16mm:9pcs	24mm:6pcs
11mm:9pcs	17mm:8pcs	27mm:5pcs
12mm:9pcs	19mm:7pcs	30mm:5pcs
13mm:9pcs	21mm:7pcs	32mm:4pcs
14mm:9pcs	22mm:6pcs	
15mm:9pcs	23mm:6pcs	

S4240A-00 4400A 103 Pieces Set/⚖️=13,000g
S4240A-05 4405A 103 Pieces Set/⚖️=13,000g

DISPLAY STAND:W510xH150xT230mm

Sockets		
3/8" :9pcs	11/16":8pcs	1" :5pcs
7/16":9pcs	3/4" :7pcs	1.1/16":5pcs
1/2" :9pcs	13/16":7pcs	1.1/8" :5pcs
9/16":9pcs	7/8" :6pcs	1.3/16":5pcs
5/8" :9pcs	15/16":6pcs	1.1/4" :4pcs

P4241M-01 Socket Sets
Steckschlüssel Sätze
P4241M-06 Jeux de clés à douilles



P4241M-01 28 Pieces Set/⚖️=6,400g

METAL CASE:W425xH332xT65mm

Sockets		Accessories	
4401M 6-pt. Sockets 10, 11, 12, 13, 14, 15, 16, 17, 18, 19, 20, 21, 22, 23, 24, 25, 26, 27, 28, 29, 30, 32			4753J
			4760-125
			4760-250
			4768J-380
			4770
			4785





P4241M-06 28 Pieces Set/⚖️=6,400g

METAL CASE:W425xH332xT65mm

Sockets		Accessories	
4406M 12-pt. Sockets 10, 11, 12, 13, 14, 15, 16, 17, 18, 19, 20, 21, 22, 23, 24, 25, 26, 27, 28, 29, 30, 32			4753J
			4760-125
			4760-250
			4768J-380
			4770
			4785

4241M-01	28 Pieces Set/△=6,500g
4241M-06	28 Pieces Set/△=6,500g
4241M-10	28 Pieces Set/△=6,500g

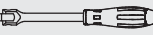
METAL CASE:W446xH266xT50mm

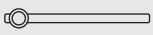
Sockets	Accessories
(4241M-01) 4401M 6-pt. Sockets 10, 11, 12, 13, 14, 15, 16, 17, 18, 19, 20, 21, 22, 23, 24, 25, 26, 27, 28, 29, 30, 32	 4753J  4760-125  4760-250  4768J-380
(4241M-06) 4406M 12-pt. Sockets 10, 11, 12, 13, 14, 15, 16, 17, 18, 19, 20, 21, 22, 23, 24, 25, 26, 27, 28, 29, 30, 32	 4770  4785
(4241M-10) 4410M Surface Drive Sockets 10, 11, 12, 13, 14, 15, 16, 17, 18, 19, 20, 21, 22, 23, 24, 25, 26, 27, 28, 29, 30, 32	







4241M-01 4241M-06 4241M-10

Socket Sets
Steckschlüssel Sätze
Jeux de clés à douilles



4241A-00	19 Pieces Set/△=4,900g
4241A-05	19 Pieces Set/△=4,900g

METAL CASE:W445xH190xT50mm

Sockets	Accessories
(4241A-00) 4400A 6-pt. Sockets 3/8, 7/16, 1/2, 9/16, 5/8, 11/16, 3/4, 13/16, 7/8, 15/16, 1.1/16, 1.1/8, 1.1/4	 4753J  4760-125  4760-250  4768J-380
(4241A-05) 4405A 12-pt. Sockets 3/8, 7/16, 1/2, 9/16, 5/8, 11/16, 3/4, 13/16, 7/8, 15/16, 1.1/16, 1.1/8, 1.1/4	 4770  4785





4241A-00 4241A-05

Socket Sets
Steckschlüssel Sätze
Jeux de clés à douilles

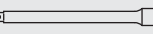

4249M-01	20 Pieces Set/△=4,800g
4249M-06	20 Pieces Set/△=4,800g

METAL CASE:W445xH190xT50mm

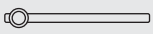
Sockets	Accessories
(4249M-01) 4401M 6-pt. Sockets 10, 11, 12, 13, 14, 15, 16, 17, 18, 19, 21, 22, 24, 27, 30	 4753J  4760-125  4760-250
(4249M-06) 4406M 12-pt. Sockets 10, 11, 12, 13, 14, 15, 16, 17, 18, 19, 21, 22, 24, 27, 30	 4770  4785



4249M-01 4249M-06

Socket Sets
Steckschlüssel Sätze
Jeux de clés à douilles

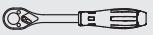
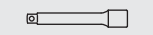
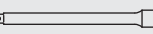

4250M-01	18 Pieces Set/△=4,700g
4250M-06	18 Pieces Set/△=4,700g
4250M-10	18 Pieces Set/△=4,700g

METAL CASE:W445xH190xT50mm

Sockets	Accessories
(4250M-01) 4401M 6-pt. Sockets 10, 11, 12, 13, 14, 15, 17, 19, 22, 24, 27, 30, 32	 4753J  4760-125  4760-250
(4250M-06) 4406M 12-pt. Sockets 10, 11, 12, 13, 14, 15, 17, 19, 22, 24, 27, 30, 32	 4770  4785
(4250M-10) 4410M Surface Drive Sockets 10, 11, 12, 13, 14, 15, 17, 19, 22, 24, 27, 30, 32	

4250M-01 4250M-06 4250M-10

Socket Sets
Steckschlüssel Sätze
Jeux de clés à douilles



Hand Sockets
Hand Steckschlüssel
Douilles à main

1/2"

Z-SERIES
HAND
TITANIUM
SCREWDRIVERS ACCESSORIES
IMPACT
SLEEVE-DRIVE
PROTECTOR
INDUSTRIAL
AUTOMOTIVE
MOTORCYCLE
CONSTRUCTION
SPARE PART

4251M-01 Socket Sets
Steckschlüssel Sätze
Jeux de clés à douilles
4251M-06
4251M-10
4251A-00
4251A-05



4251M-01	22 Pieces Set/⚖️=3,200g
4251M-06	22 Pieces Set/⚖️=3,200g
4251M-10	22 Pieces Set/⚖️=3,200g
4251A-00	18 Pieces Set/⚖️=2,700g
4251A-05	18 Pieces Set/⚖️=2,700g

METAL CASE:W330xH68xT48mm

Sockets	
(4251M-01) 4401M 6-pt. Sockets	10, 11, 12, 13, 14, 15, 16, 17, 18, 19, 20, 21, 22, 23, 24, 25, 26, 27, 28, 29, 30, 32
(4251M-06) 4406M 12-pt. Sockets	
(4251M-10) 4410M Surface Drive Sockets	
(4251A-00) 4400A 6-pt. Sockets	3/8, 7/16, 1/2, 9/16, 19/32, 5/8, 21/32, 11/16, 3/4, 25/32, 13/16, 7/8, 15/16, 1, 1.1/16, 1.1/8, 1.3/16, 1.1/4
(4251A-05) 4405A 12-pt. Sockets	

4252M-01 Socket Sets
Steckschlüssel Sätze
Jeux de clés à douilles
4252M-06
4252M-10



4252M-01	13 Pieces Set/⚖️=1,200g
4252M-06	13 Pieces Set/⚖️=1,200g
4252M-10	13 Pieces Set/⚖️=1,200g

METAL CASE:W168xH60xT42mm

Sockets	
(4252M-01) 4401M 6-pt. Sockets	10, 11, 12, 13, 14, 15, 16, 17, 18, 19, 20, 21, 22
(4252M-06) 4406M 12-pt. Sockets	
(4252M-10) 4410M Surface Drive Sockets	

4254 Socket Sets
Steckschlüssel Sätze
Jeux de clés à douilles



4254	12 Pieces Set/⚖️=1,070g
------	-------------------------

METAL CASE:W215xH80xT47mm

Sockets	Accessories
3425 - E6, E8	4763-50
4425 - E10, E12, E14	4433A-35
3325 - E6, E8	
4325 - E10, E12, E14	





4262M-01 Socket Sets
Steckschlüssel Sätze
Jeux de clés à douilles
4262M-06
4262M-10



4262M-01	20 Pieces Set/⚖️=4,400g
4262M-06	20 Pieces Set/⚖️=4,400g
4262M-10	20 Pieces Set/⚖️=4,400g

METAL CASE:W445xH190xT50mm

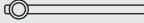

Sockets	Accessories
(4262M-01) 4401M 6-pt. Sockets 8, 10, 11, 12, 13, 14, 15, 16, 17, 18, 19, 21, 22, 24, 27	4753J
(4262M-06) 4406M 12-pt. Sockets 8, 10, 11, 12, 13, 14, 15, 16, 17, 18, 19, 21, 22, 24, 27	4760-125
(4262M-10) 4410M Surface Drive Sockets 8, 10, 11, 12, 13, 14, 15, 16, 17, 18, 19, 21, 22, 24, 27	4760-250
	4770
	4785

4272AM-01		29 Pieces Set/△=5,000g	
4272AM-06		29 Pieces Set/△=5,000g	
METAL CASE:W445xH190xT50mm			
Sockets		Accessories	
(4272AM-01)			
○	4401M 6-pt. Sockets 10, 11, 12, 13, 14, 15, 16, 17, 18, 19, 21, 22, 24		4753J
			4760-125
			4760-250
○	4400A 6-pt. Sockets 3/8, 7/16, 1/2, 9/16, 5/8, 11/16, 3/4, 13/16, 7/8, 15/16, 1		4770
			4785
(4272AM-06)			
○	4406M 12-pt. Sockets 10, 11, 12, 13, 14, 15, 16, 17, 18, 19, 21, 22, 24		
○	4405A 12-pt. Sockets 3/8, 7/16, 1/2, 9/16, 5/8, 11/16, 3/4, 13/16, 7/8, 15/16, 1		

4272AM-01 4272AM-06

Socket Sets
Steckschlüssel Sätze
Jeux de clés à douilles

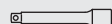
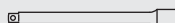

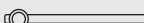
4275		24 Pieces Set/△=5,340g	
METAL CASE:W445xH190xT50mm			
Sockets		Accessories	
○	4406M 12-pt. Sockets 10, 11, 12, 13, 14, 15, 16, 17, 18, 19, 21, 22, 24		4750J
			4760-125
			4760-250
○	4300C Spark Plug Sockets 16, 20.8		4768J-380
○	4300M Wheel Nut Sockets 17(L60), 19(L60), 21(L60)		4770
			4785

4275

Socket Sets
Steckschlüssel Sätze
Jeux de clés à douilles

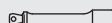

4276		17 Pieces Set/△=2,890g	
METAL CASE:W370xH150xT50mm			
Sockets		Accessories	
●	4010M.50 Bit Sockets 6, 7, 8, 10, 12, 14		4752J
★	4025.60 TORX® Bit Sockets T20, T25, T27, T30, T40, T45, T50, T55, T60		4763-125

4276

Socket Sets
Steckschlüssel Sätze
Jeux de clés à douilles

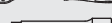
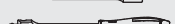

4277		27 Pieces Set/△=5,660g	
METAL CASE:W445xH190xT50mm			
Sockets		Accessories	
○	4406M 12-pt. Sockets 10, 12, 13, 14, 15, 16, 17, 18, 19, 21, 22, 24		4750J
			4760-125
			4768J-380
○	4305M 12-pt. Deep Sockets 10, 12, 13, 14, 15, 16, 17, 18, 19, 21, 22, 24		

4277

Socket Sets
Steckschlüssel Sätze
Jeux de clés à douilles



6300M / 6300A

6-point Deep Sockets
6-kant-Steckschlüssel, lang
Douilles longues 6-pans

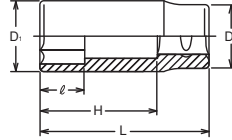

6300M 6305M (mm)	D ₁ (mm)	D ₂ (mm)	l (mm)	H (mm)	L (mm)	(g)	(pcs.)
17	26	34	18	64	90	278	5
18	27	34	19	64	90	281	5
19	28.5	34	20	64	90	292	5
20	29.5	34	21	64	90	334	5
21	31	34	22	64	90	343	5
22	32	34	23	64	90	347	5
23	33.5	34	24	64	90	361	5
24	34.5	34	25	64	90	352	5
25	36	34	26	64	90	369	5
26	37	34	27	64	90	384	5
27	38.5	37	28	64	90	425	5
28	39.5	38	29	63	90	470	5
29	41	38	30	63	90	503	5
30	42	38	31	63	90	503	5
31	43.5	38	32	62	90	517	5
32	44.5	40	34	62	90	544	5
33	46	40	34	62	90	557	5
34	47	40	35	61	90	570	5
35	48.5	42	36	61	90	622	5
36	49.5	42	37	61	90	631	2
38	52	45	39	60	90	710	2
40	54.5	45	41	60	90	742	2
41	56	47	42	59	90	802	2
42	57	47	43	59	90	829	2
44	59.5	47	45	59	90	838	2
46	62	47	47	58	90	906	2
48	64.5	50	49	57	90	998	2
50	67	48	51	57	90	1005	2
52	69.5	53	49	-	100	1270	2
53	71	54	49	-	100	1338	2
54	72	55	49	-	100	1351	2
55	73.5	53	52	-	100	1388	2
56	74.5	53	52	-	100	1389	2
57	76	53	52	-	100	1467	2
58	77	53	52	-	100	1480	2
60	79.5	58	55	-	100	1626	2
63	83.5	58	55	-	100	1740	2
65	86	63	65	-	100	1939	2

6305M / 6305A

12-point Deep Sockets
12-kant Steckschlüssel, lang
Douilles longues, 12-pans



6300A 6305A (inch)	D ₁ (mm)	D ₂ (mm)	l (mm)	H (mm)	L (mm)	(g)	(pcs.)
3/4	28.5	34	20	64	90	292	5
25/32	29.5	34	21	64	90	334	5
13/16	31	34	22	64	90	343	5
7/8	32	34	23	64	90	347	5
15/16	34.5	34	25	64	90	352	5
1	37	34	27	64	90	384	5
1. 1/16	38.5	37	28	64	90	425	5
1. 1/8	41	38	30	63	90	503	5
1. 3/16	42	38	31	63	90	503	5
1. 1/4	44.5	40	34	62	90	544	5
1. 5/16	46	40	34	62	90	557	5
1. 3/8	48.5	42	36	61	90	622	5
1. 7/16	51	42	38	61	90	656	2
1. 1/2	52	45	39	60	90	710	2
1. 9/16	54.5	45	41	60	90	742	2
1. 5/8	56	47	42	59	90	802	2
1.11/16	58.5	47	44	59	90	831	2
1. 3/4	59.5	47	45	59	90	838	2
1.13/16	62	47	47	58	90	906	2
2	68.5	52	52	57	90	1061	2
2. 1/16	71	54	49	-	100	1338	2
2. 1/8	72	55	49	-	100	1351	2
2. 3/16	74.5	53	52	-	100	1389	2
2. 1/4	76	53	52	-	100	1467	2
2. 5/16	78.5	53	52	-	100	1787	2
2. 3/8	79.5	58	55	-	100	1626	2
2. 7/16	82	58	55	-	100	1715	2

6012M-75

Inhex Sockets
Steckschlüssel für Innensechskant-Schrauben
Douilles tournevis pour vis 6-pans creux

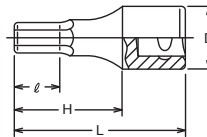

6012M.75 (mm)	D (mm)	l (mm)	H (mm)	L (mm)	(g)	(pcs.)
12	35	15.5	40	75	253	10
14	35	15.5	40	75	265	10
15	35	15.5	40	75	271	10
16	35	15.5	40	75	285	10
17	35	15.5	40	75	292	10
18	35	15.5	40	75	302	10
19	35	15.5	40	75	312	10
20	35	15.5	40	75	323	10
21	38	15.5	40	75	330	10
22	38	22.5	40	75	340	10
24	38	22.5	40	75	362	10
27	38	22.5	40	75	402	10
30	38	28.5	40	75	445	10
32	38	28.5	40	75	485	10
36	42	28.5	40	75	663	10

6101

Socket for Slotted Heads
Steckschlüssel für Schlitzschrauben
Douilles tournevis pour vis à fente

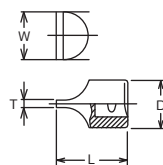

	TxW (mm)	D (mm)	L (mm)	(g)	(pcs.)
6101	6.4x33.5	35	50	205	10

Z-SERIES
HAND
TITANIUM
SCREWDRIVERS ACCESSORIES
IMPACT
SLEEVE-DRIVE
PROTECTOR
INDUSTRIAL
AUTOMOTIVE
MOTORCYCLE
CONSTRUCTION
SPARE PART

6749 / 6749-1000 6749-HEAD PIPE-400/-800

Reversible Ratchet
Knarre, verstellbar
Cliquet, réversible



* Renewal Kits → 6749RK → P299

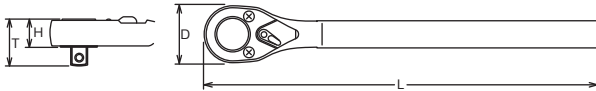

	D (mm)	T (mm)	H (mm)	L (mm)	(g)	(pce.)
6749	68	49.6	29.6	565	2840	1
6749-1000	68	49.6	29.6	965	3960	1
New 6749-HEAD	68	49.6	29.6	165	1730	1
New PIPE-400	-	-	-	400	1110	1
New PIPE-800	-	-	-	800	2230	1



6752 6752-HEAD PIPE-400

Reversible Ratchet
Knarre, verstellbar
Cliquet, réversible



* Renewal Kits → 6752RK → P299

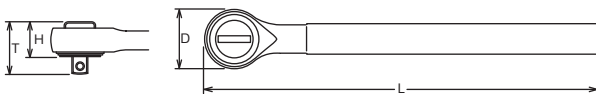

	D (mm)	T (mm)	H (mm)	L (mm)	(g)	(pce.)
6752	67	55.5	35.5	500	2360	1
New 6752-HEAD	67	55.5	35.5	100	1250	1
New PIPE-400	-	-	-	400	1110	1



60

* Renewal Kits → 6755RK → P300

	D (mm)	L (mm)	(g)	(pce.)
6755	62	97	1162	1

6755 Ratchet Adaptor
Aufstecknarre
Cliquet adaptable

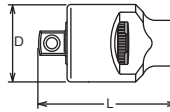

6760-75/-100/-125/-150/-200/-300/-400

Extension Bars
Verlängerungen
Rallonges



6760	D (mm)	L (mm)	(g)	(pce.)
75	35	75	335	10
100	35	100	434	10
125	35	125	528	10
150	35	150	624	2
200	35	200	815	1
300	35	300	1203	1
400	35	400	1585	1



6768 Hinge Handle
Gelenkgriff
Poignée articulée



* Renewal Kits → 6768RK → P300

	D (mm)	L (mm)	(g)	(pce.)
6768	42	450	1715	1

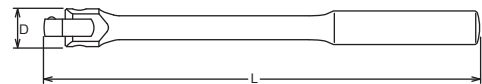

6768-600/-1000 Hinge Handle
Gelenkgriff
Poignée articulée
6768-HEAD
PIPE-400/800



* Renewal Kits → 6768RK → P300

6768	D (mm)	L (mm)	(g)	(pce.)
6768-600	42	600	2360	1
6768-1000	42	1000	3480	1
New 6768-HEAD	42	200	1250	1
New PIPE-400	-	400	1110	1
New PIPE-800	-	800	2230	1

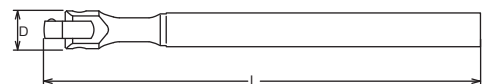

Z-SERIES
HAND
TITANIUM
SCREWDRIVERS ACCESSORIES
IMPACT
SLEEVE-DRIVE
PROTECTOR
INDUSTRIAL
AUTOMOTIVE
MOTORCYCLE
CONSTRUCTION
SPARE PART

6785 T-Handle
T-Griff
Poignée coulissante

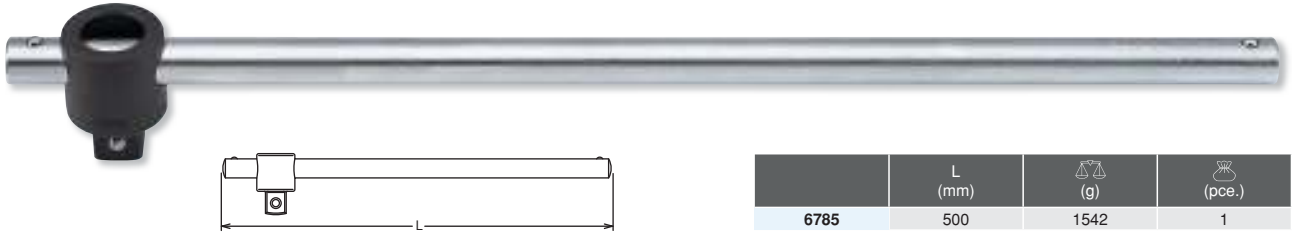

	L (mm)	(g)	(pce.)
6785	500	1542	1

6788 L-Handle
L-Griff
Poignée en L

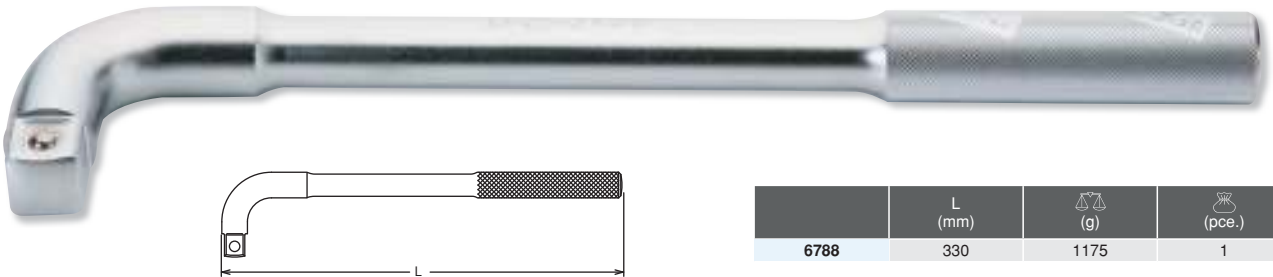

	L (mm)	(g)	(pce.)
6788	330	1175	1

6770 Universal Joint
Gelenk-Einsatz
Cardan universel

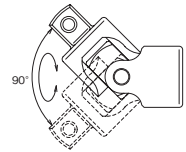

	L (mm)	(g)	(pcs.)
6770	105	478	2

6644A Adaptor
Verbindungsstück
Réducteur
Warranty 668Nm
Garantie 668Nm
Garantie 668Nm



	(sq.)	(sq.)	L (mm)	(g)	(pcs.)
6644A	3/4"	1/2"	47	136	5
6688A	3/4"	1"	60	285	5

Adapting down from bigger square drive to smaller square drive may lead to excessive torque load and possibly cause breakage. Always stay within safe torque of the smaller square drive.

Die mit gekennzeichneten Artikel können bei Überbelastung zu Bruch gehen. Aus Gründen Ihrer eigenen Sicherheit sollten die betreffenden Werkzeuge nie ruckartig, sondern nach und nach belastet werden, um Bruch und damit verbundene mögliche Verletzungen zu vermeiden.

Il est possible d'appliquer aux articles marqués des couples de serrage susceptibles d'occasionner leur rupture. Pour votre propre sécurité, veuillez toujours appliquer la charge d'une manière uniforme et progressive. Ceci pour éviter ruptures et accidents.

6688A Adaptor
Verbindungsstück
Augmentateur



3/4"

Hand Sockets
Hand Steckschlüssel
Douilles à main

6201M-00
6201A-00
6201M-05
6201A-05

Socket Sets
Steckschlüssel Sätze
Jeux de clés à douilles



6201A-00 18 Pieces Set/△=17,600g
6201A-05 18 Pieces Set/△=17,600g

METAL CASE:W580xH200xT85mm

Sockets	Accessories
(6201A-00) 6400A 6-pt. Sockets 7/8, 15/16, 1.1/16, 1.1/8, 1.1/4, 1.5/16, 1.7/16, 1.1/2, 1.5/8, 1.11/16, 1.13/16, 1.7/8, 2	6749 6760-200 6760-400 6768
(6201A-05) 6405A 12-pt. Sockets 7/8, 15/16, 1.1/16, 1.1/8, 1.1/4, 1.5/16, 1.7/16, 1.1/2, 1.5/8, 1.11/16, 1.13/16, 1.7/8, 2	6785

6201M-00 16 Pieces Set/△=17,300g
6201M-05 16 Pieces Set/△=17,300g

METAL CASE:W580xH200xT85mm

Sockets	Accessories
(6201M-00) 6400M 6-pt. Sockets 22, 24, 27, 30, 32, 36, 41, 46, 50, 55, 60	6749 6760-200 6760-400 6768
(6201M-05) 6405M 12-pt. Sockets 22, 24, 27, 30, 32, 36, 41, 46, 50, 55, 60	6785

6212M-00
6212M-05

Socket Sets
Steckschlüssel Sätze
Jeux de clés à douilles



6212M-00 12 Pieces Set/△=8,200g
6212M-05 12 Pieces Set/△=8,200g

METAL CASE:W580xH124xT70mm

Sockets	Accessories
(6212M-00) 6400M 6-pt. Sockets 22, 24, 27, 30, 32, 36, 41, 46, 50	6749 6760-200 6785
(6212M-05) 6405M 12-pt. Sockets 22, 24, 27, 30, 32, 36, 41, 46, 50	

8405M / 8405A ○ 12-point Sockets
12-kant Steckschlüssel
Douilles 12-pans

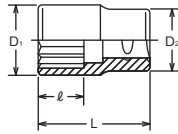

8400M / 8400A ○ 6-point Sockets
6-kant Steckschlüssel
Douilles 6-pans

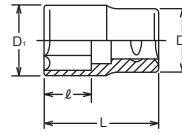

8400A 8405A (inch)	D ₁ (mm)	D ₂ (mm)	ℓ (mm)	L (mm)	(g)	(pce.)
15/16	36.5	44	17	60	355	1
1. 3/16	44	45	21	65	410	1
1. 1/4	46.5	45	23	65	455	1
1. 5/16	48	46	23.5	65	485	1
1. 3/8	50.5	48	24.5	65	536	1
1. 7/16	53	50	25.5	65	607	1
1. 1/2	54	50	26	65	624	1
1. 9/16	56.5	53	27	65	686	1
1. 5/8	58	53	28	68	747	1
1.11/16	60.5	53	29	68	830	1
1. 3/4	61.5	53	29.5	68	807	1
1.13/16	64	53	31	72	928	1
1. 7/8	66.5	53	32	72	936	1
1.15/16	68	53	32.5	72	941	1
2	70.5	53	37	72	976	1
2. 1/16	73	54	37	72	1027	1
2. 1/8	74	55	37	72	1016	1
2. 3/16	76.5	53	41	77	1192	1
2. 1/4	78	53	41	77	1177	1
2. 5/16	80.5	53	41	77	1292	1
2. 3/8	81.5	58	46	82	1440	1
2. 7/16	84	58	45	82	1495	1
2. 1/2	86.5	58	45	82	1497	1
2. 9/16	88	63	49	86	1683	1
2. 5/8	90.5	63	49	86	1840	1
2.11/16	91.5	63	49	86	1800	1
2. 3/4	94	68	50	88	1963	1
2.13/16	96.5	68	50	88	2035	1
2. 7/8	98	70	50	88	2100	1
2.15/16	100.5	73	53	90	2204	1
3	103	75	53	90	2406	1
3. 1/8	106.5	75	58	95	2550	1
3. 1/4	110.5	78	57	95	2730	1
3. 3/8	114	80	57	95	3050	1
3. 1/2	119	80	59	100	3420	1
3. 3/4	125.5	85	58	100	4900	1

8400M 8405M (mm)	D ₁ (mm)	D ₂ (mm)	ℓ (mm)	L (mm)	(g)	(pce.)
24	36.5	44	17	60	348	1
27	40.5	44	19	60	362	1
New 28	41.5	44	19.5	60	368	1
New 29	43	44	20	60	378	1
30	44	45	21	65	410	1
32	46.5	45	23	65	455	1
33	48	46	23.5	65	485	1
New 34	49	46	24	65	500	1
35	50.5	48	24.5	65	536	1
36	51.5	48	25	65	600	1
38	54	50	26	65	624	1
40	56.5	53	27	65	686	1
41	58	53	28	68	747	1
42	59	53	28.5	68	789	1
46	64	53	31	72	928	1
50	69	53	34	72	943	1
54	74	55	37	72	1016	1
55	75.5	53	42	77	1167	1
New 56	76.5	53	42	77	1160	1
58	79	53	41	77	1200	1
60	81.5	58	46	82	1440	1
63	85.5	58	45	82	1470	1
65	88	63	49	86	1683	1
67	90.5	63	49	86	1840	1
68	91.5	63	49	86	1800	1
70	94	68	50	88	1963	1
71	95.5	68	50	88	2200	1
75	100.5	73	53	90	2204	1
78	104	75	52.5	90	2500	1
80	106.5	75	58	95	2550	1
83	110.5	78	57	95	2730	1
85	113	80	57	95	2680	1
90	119	80	59	100	3420	1
95	125.5	85	58	100	4900	1
100	131.5	85	57	100	4840	1

8012M-80 (mm)	D (mm)	ℓ (mm)	H (mm)	L (mm)	(g)	(pcs.)
17	44.2	15.5	45	80	400	5
19	44.2	15.5	45	80	410	5
22	47.9	22.5	45	80	436	5
24	47.9	22.5	45	80	471	5
27	47.9	22.5	45	80	526	5
30	47.9	22.5	45	80	658	5
32	47.9	22.5	45	80	715	5
36	54.2	22.5	45	80	945	5

8012M-80

Inhex Sockets
Steckschlüssel für Innensechskant-Schrauben
Douilles tournevis pour vis 6-pans creux

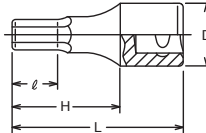

8760-200/-400

Extension Bars
Verlängerungen
Rallonges



8760	D (mm)	L (mm)	(g)	(pce.)
200	44	200	1300	1
400	44	400	2570	1



8770	L (mm)	(g)	(pce.)
8770	143	1170	1

8770

Universal Joint
Gelenk-Einsatz
Cardan universel

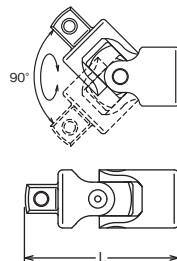

8866A	(mm)	(mm)	L (mm)	(g)	(pcs.)
8866A	1"	3/4"	60	338	5

⚠ Adapting down from bigger square drive to smaller square drive may lead to excessive torque and possibly cause breakage.

Reduzierstücke sind mit Vernunft einzusetzen.
Es besteht Bruchgefahr. Überschreiten Sie niemals die Sicherheitsgrenzen.

Les réducteurs doivent être utilisés avec modération. Ne dépassez jamais les limites de sécurité.

8866A

Adaptor
Verbindungsstück
Réducteur

Warranty 1850Nm
Garantie 1850Nm
Garantie 1850Nm **⚠**

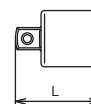

Z-SERIES
HAND
TITANIUM
SCREWDRIVERS ACCESSORIES
IMPACT
SLEEVE-DRIVE
PROTECTOR
INDUSTRIAL
AUTOMOTIVE
MOTORCYCLE
CONSTRUCTION
SPARE PART

8749
8749-HEAD
PIPE-580/-800

Reversible Ratchet
Knarre, verstellbar
Cliquet, réversible



* Renewal Kits → 8749RK → P299

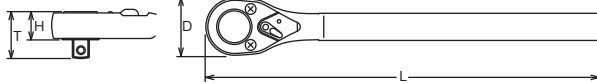

	D (mm)	T (mm)	H (mm)	L (mm)	(g)	(pce.)
8749	70	62.2	36.2	800	4100	1
8749-1000	70	62.2	36.2	1020	4720	1
New 8749-HEAD	70	62.2	36.2	220	2490	1
New PIPE-580	-	-	-	580	1610	1
New PIPE-800	-	-	-	800	2230	1

8768
8768-HEAD
PIPE-400/-800

Hinge Handle
Gelenkgriff
Poignée articulée

* Renewal Kits → 8768RK → P300

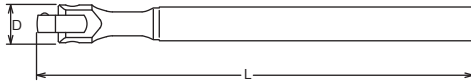

	D (mm)	L (mm)	(g)	(pce.)
8768	55	600	2590	1
8768-1000	55	1000	3710	1
New 8768-HEAD	55	200	1480	1
New PIPE-400	-	400	1110	1
New PIPE-800	-	800	2230	1

8785 / 8785-700

T-Handle
T-Griff
Poignée coulissante

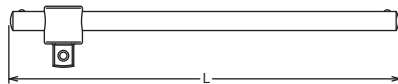

	L (mm)	(g)	(pce.)
8785	550	3190	1
New 8785-700	700	3906	1

8788

L-Handle
L-Griff
Poignée en L

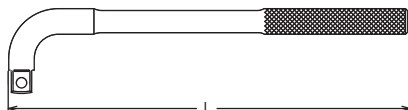
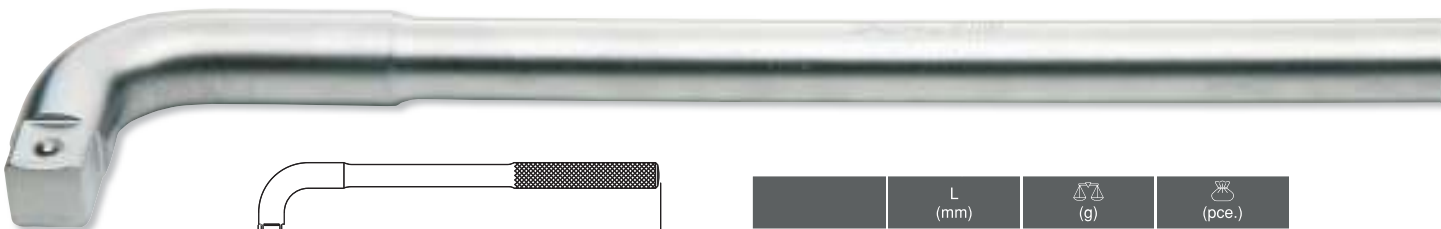

	L (mm)	(g)	(pce.)
8788	600	3600	1

1”

Hand Sockets
Hand Steckschlüssel
Douilles à main



Hand Sockets
Hand Steckschlüssel 1"
Douilles à main

Z-SERIES
HAND
TITANIUM
SCREWDRIVERS ACCESSORIES
IMPACT
SLEEVE-DRIVE
PROTECTOR
INDUSTRIAL
AUTOMOTIVE
MOTORCYCLE
CONSTRUCTION
SPARE PART

8225M-00 Socket Sets
Steckschlüssel Sätze
Jeux de clés à douilles
8225M-05



8225M-00	15 Pieces Set/重量=27,000g
8225M-05	15 Pieces Set/重量=27,000g
METAL CASE:W600xH217xT97mm	
Sockets	Accessories
(8225M-00) 8400M 6-pt. Sockets 32, 33, 36, 41, 46, 50, 55, 60, 65, 70, 75, 80	8749
(8225M-05) 8405M 12-pt. Sockets 32, 33, 36, 41, 46, 50, 55, 60, 65, 70, 75, 80	8760-200
	8760-400



TITAN-SOCKETS & ACCESSORIES
TITAN STECKSCHLÜSSEL UND ZUBEHÖRTEILE
DOUILLES ET ACCESSOIRES TITAN

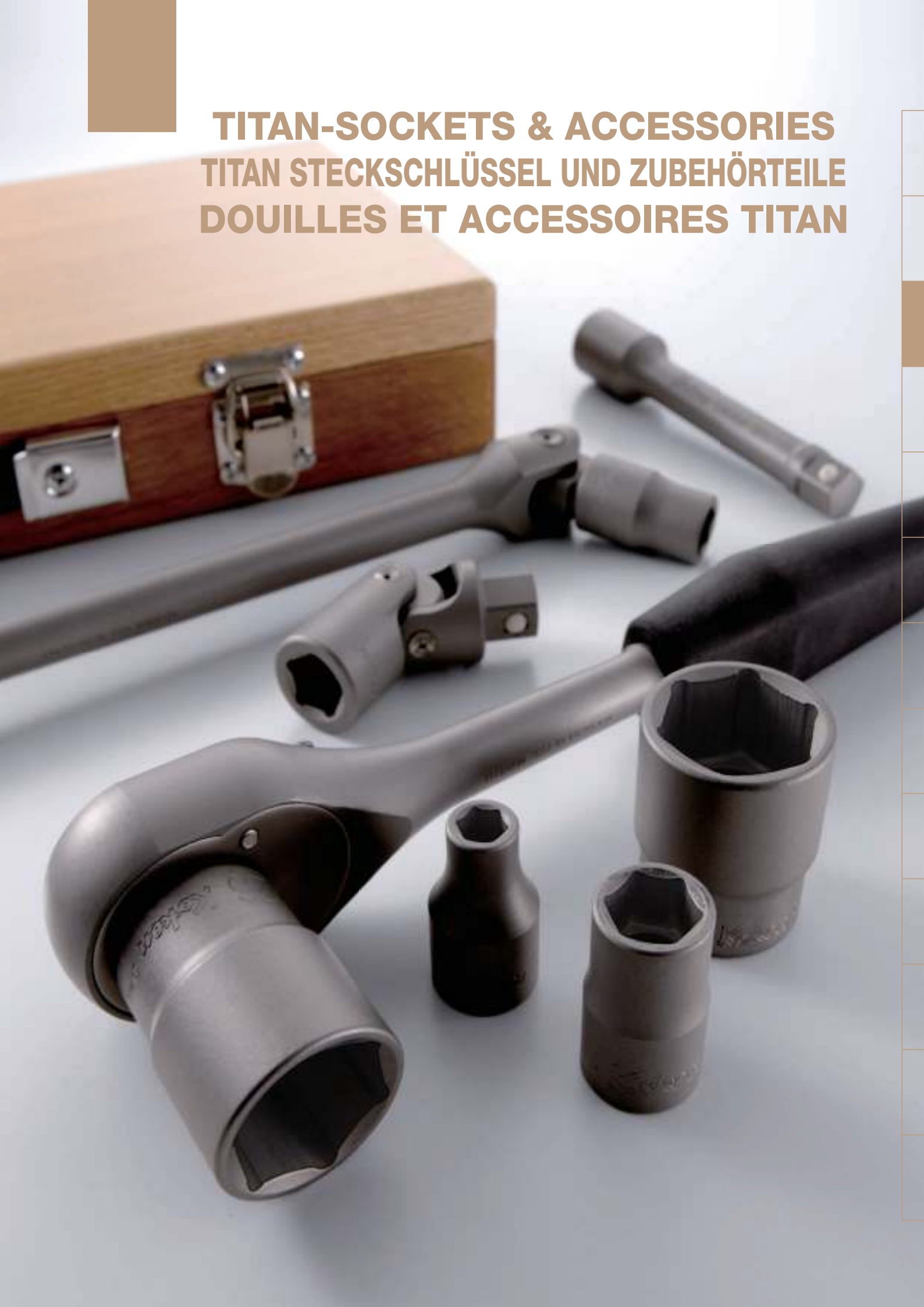





Z-SERIES
HAND
TITANIUM
ACCESSORIES
SCREWDRIVERS
IMPACT
SLEEVE-DRIVE
PROTECTOR
INDUSTRIAL
AUTOMOTIVE
MOTORCYCLE
CONSTRUCTION
SPARE PART

TI4261M

Socket Set Titanium
Steckschlüssel Satz Titanium
Jeu de clés à douille Titanium

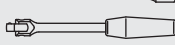

TI4261M		18 Pieces Set/△=4,280g	
WOODEN CASE:W445xH190xT60mm			
Sockets		Accessories	
	TI4400M 6-pt. Sockets 8, 10, 11, 12, 13, 14, 17, 19, 21, 22, 24, 26, 27		TI4749J
			TI4760-125
			TI4760-250
			TI4768J-380
			TI4770

Characteristic of TITAN

- Light weight** : Makes it effective for operating tools. The specific gravity is only about 58% of chrome molybdenum steel which is used for our normal products.
- Non-Corrosion** : Corrosion Resistance is greatly improved against salt water and any kind of chemical products.
- Non-Magnetic** : Non-Magnetic material will prevent the tools from magnetizing.

Eigenschaften der TITAN Legierung

- Geringes Gewicht** : Das spezifische Gewicht liegt bei 58% herkömmlicher Chrom-Molybdän Stähle.
- Korrosionsfest** : Meerwasser oder Säuren hinterlassen keine Spuren.
- Nicht magnetisch** : Titan Werkzeuge lassen sich nicht magnetisieren.

Caractéristiques de l'alliage TITAN

- Légèreté** : Son poids spécifique n'est que 58% de celui de l'acier au chrome-molybdène utilisé pour tous nos produits standards.
- Anti-corrosion** : Aussi bien pour l'eau que pour tous les produits chimiques.
- Anti-magnétique** : Le Titan empêche toute magnétisation de l'outil.



Pentagonal drive is designed to avoid using with normal square drive items, so that it will provide extra safety and much more strength.

Der 5-kant Antrieb (Pentagon-Drive) gewährt einen kraftvollen Anzug und unterbindet aus Sicherheitsgründen die Verwendung von Zubehörteilen anderer Legierungen.

L'entraînement pentagonal est conçu pour obtenir un serrage puissant et pour empêcher l'utilisation d'accessoires traditionnels et ce pour des raisons de sécurité.



ACCESSORIES
ZUBEHÖRTEILE
ACCESSOIRES



Z-SERIES
 HAND
 TITANIUM
 ACCESSORIES
 SCREWDRIVERS
 IMPACT
 SLEEVE-DRIVE
 PROTECTOR
 INDUSTRIAL
 AUTOMOTIVE
 MOTORCYCLE
 CONSTRUCTION
 SPARE PART

4100M / 4100A ○ Screw and Stud Pullers
 Stehbolzendreher
 Extracteurs de goujons

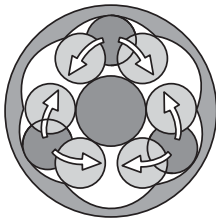
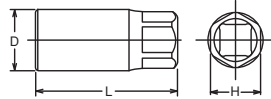

Screw and Stud Pullers
 Hexagon body design can lessen the excessive load on cages and rollers inside the pullers.

Stehbolzendreher
 Der neue Körper mit sechs Walzenmulden verteilt den Druck auf Käfig und Walzen weitaus vorteilhafter.

Extracteurs de goujons
 Le nouveau corps de forme hexagonale répartit l'effort de façon plus uniforme sur la cage et les rouleaux.

4100M (mm)	□	D (mm)	L (mm)	H (mm)	(g)	(pcs.)	
5	1/2"	24	65	21	145	10	
6		24	65	21	150	10	
7		24	65	21	150	10	
8		24	65	21	147	10	
9		28	75	21	217	10	
10		28	75	21	213	10	
10.5		28	75	21	202	10	
11		28	75	21	218	10	
12		28	75	21	220	10	
14		34	75	27	340	5	
16		-⚠	34	75	27	315	5

4100A (inch)	□	D (mm)	L (mm)	H (mm)	(g)	(pcs.)
1/4	1/2"	24	65	21	150	10
5/16		24	65	21	147	10
3/8		28	75	21	213	10
7/16		28	75	21	218	10
1/2		28	75	21	191	10
9/16		34	75	27	340	5
5/8	-⚠	34	75	27	315	5

* Renewal Kits → **4100MRK/4100ARK** → P301
 ⚠ 4100M-16 and 4100A-5/8 do not have 1/2" square drive.
 Drive the outer hexagon part with 27mm sockets or ring wrenches.
 Die Artikel 4100M 16mm und 4100A 5/8" haben keinen 1/2" Antriebsvierkant.
 Bitte benutzen Sie den 27mm Aussensechskant.
 Les articles 4100M-16 et 4100A-5/8" n'ont pas de carré entraînant 1/2" , veuillez utiliser l'hexagonal 6 pans 27 mm

Tolerance			
	4100M (mm)		4100A (inch)
5	4.7- 5	1/4	6 - 6.4
6	5.6- 6	5/16	7.6- 8
7	6.6- 7	3/8	9 - 9.6
8	7.6- 8	7/16	10.5-11.1
9	8.4- 9	1/2	12.1-12.7
10	9.4-10	9/16	13.5-14.3
10.5	9.9-10.5	5/8	15.2-16
11	10.4-11		
12	11.4-12		
14	13.2-14		
16	15.2-16		

4211M / 4211A ○ Screw and Stud Pullers Sets
 Stehbolzendreher im Satz
 Jeux d'extracteurs de goujons



4211M 4 Pieces Set/△=1,040g
 METAL CASE:W215xH80xT47mm
 PULLER
 ○ 4100M Stud Pullers
 6, 8, 10, 12

4211A 4 Pieces Set/△=1,040g
 METAL CASE:W215xH80xT47mm
 PULLER
 ○ 4100A Stud Pullers
 1/4, 5/16, 3/8, 1/2

4214M ○ Screw and Stud Pullers Set
 Stehbolzendreher im Satz
 Jeux d'extracteurs de goujons



4214M 5 Pieces Set/△=1,450g
 METAL CASE:W215xH80xT47mm
 PULLER
 ○ 4100M Stud Pullers
 6, 8, 10, 12, 14

6100M (mm)		D (mm)	L (mm)	H (mm)	(g)	(pcs.)
18	3/4"	48	100	36	840	1
20		48	100	36	816	1
22		48	100	36	745	1
24		48	100	36	739	1
27		63	125	46	1707	1
28		63	125	46	1701	1
29		63	125	46	1696	1
30		63	125	46	1691	1

* Renewal Kits → 6100MRK → P301

6100M-22 to -30 do not have 3/4" square drive.
Drive the outer hexagon part with sockets or ring wrenches
(size 22-24mm = 36H, 27-30mm = 46H.)
Die Stehbolzendreher ab Abmessung 22mm haben keinen 3/4" Antriebsvierkant.
Bitte benutzen sie den Aussensechskant.

Tolerance

6100M (mm)	Tolerance (mm)
18	16.9-18
20	18.8-20
22	20.8-22
24	22.7-24
27	25.7-27
28	26.7-28
29	27.6-29
30	28.6-30

6100M Screw and Stud Pullers
Stehbolzendreher
Extracteurs de goujons

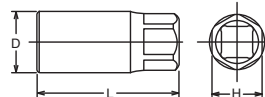

14100M (mm)		D ₁ (mm)	D ₂ (mm)	L (mm)	(g)	(pcs.)	
6	1/2"	24	25	48	126	10	*1
7		24	25	48	126	10	*1
8		24	25	48	122	10	*1
9		28	30	48	181	10	*2
10		28	30	48	181	10	*2
12		28	30	48	175	10	*2

14100A (inch)		D ₁ (mm)	D ₂ (mm)	L (mm)	(g)	(pcs.)	
1/4	1/2"	24	25	48	126	10	*1
5/16		24	25	48	122	10	*1
3/8		28	30	48	181	10	*2
7/16		28	30	48	181	10	*2
1/2		28	30	48	180	10	*2

*1 C-Ring=1401C, Pin/O-Ring=1401A/B → P250-251
*2 C-Ring=1402C, Pin/O-Ring=1402A/B

Tolerance

14100M (mm)	Tolerance (mm)	14100A (inch)	Tolerance (inch)
6	5.6- 6	1/4	6 - 6.4
7	6.6- 7	5/16	7.6- 8
8	7.6- 8	3/8	9 - 9.6
9	8.4- 9	7/16	10.5-11.1
10	9.4-10	1/2	12.1-12.7
12	11.4-12		

14100M / 14100A IMPACT Screw and Stud Pullers
IMPACT Stehbolzendreher
Extracteurs de goujons IMPACT

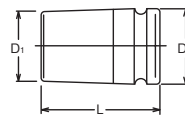

Stud Pullers & Setters
 Stehbolzendreher
 Extracteurs de goujons

Z-SERIES
 HAND
 TITANIUM
 ACCESSORIES
 SCREWDRIVERS
 IMPACT
 SLEEVE-DRIVE
 PROTECTOR
 INDUSTRIAL
 AUTOMOTIVE
 MOTORCYCLE
 CONSTRUCTION
 SPARE PART

141S / 141 Stud Puller Ratchets
 Stehbolzensausdreher-Knarren
 Dégoujoneuses à cliquet

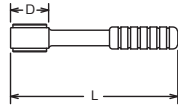

141S (mm)	D (mm)	L (mm)	(g)	(pce.)
6	28	120	150	1
8	28	120	150	1
10	32	120	153	1
12	32	120	152	1

141S (inch)	D (mm)	L (mm)	(g)	(pce.)
5/16	28	120	150	1
3/8	32	120	153	1
1/2	32	120	152	1

141 (mm)	D (mm)	L (mm)	(g)	(pce.)
6	28	205	215	1
8	28	205	215	1
10	32	205	234	1
12	32	205	233	1

141 (inch)	D (mm)	L (mm)	(g)	(pce.)
5/16	28	205	215	1
3/8	32	205	234	1
1/2	32	205	233	1

141P Stud Puller Ratchets
 Stehbolzensausdreher-Knarren
 Dégoujoneuses à cliquet

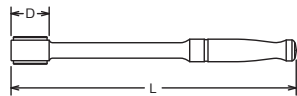

141P (mm)	D (mm)	L (mm)	(g)	(pce.)
6	28	205	210	1
8	28	205	210	1
10	32	205	229	1
12	32	205	227	1

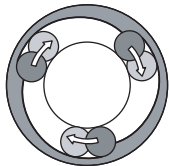

The three roller system can protect the studs from damage.
 Das Drei-Rollen-System schützt die Stehbolzen.
 Le système à trois roulettes n'endommage pas les goujons.



1201 Stud Puller Ratchets
 Stehbolzensausdreher-Knarren
 Dégoujoneuses à cliquet



1201 4 Pieces Set/△=973g
 METAL CASE:W240xH100xT32mm
 PULLER
 141S Stud Puller Ratchet
 6, 8, 10, 12

4104 Screw and Stud Puller
 Stehbolzendreher
 Extracteur de goujons

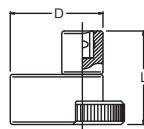

4104	□	Tolerance		D (mm)	L (mm)	(g)	(pcs.)
		min	max				
	1/2	φ 6	φ 19	54	56	489	2

4103M (mm)		D ₁ (mm)	D ₂ (mm)	ℓ (mm)	L (mm)	(g)	(pcs.)
6(1.0)	1/2"	10.3	22	9	37	54	10
7(1.0)		11.5	22	10	37	58	10
8(1.25)		13.2	22	11	37	60	10
10(1.25)		15.3	23	13	44	86	10
10(1.5)		15.3	23	13	44	86	10
12(1.25)		17.8	23	14	44	86	10
12(1.75)		17.8	23	14	44	86	10

4203M	4 Pieces Set/△=530g
METAL CASE:W130×H65×T26mm	
Stud Bolt Setter	
	4103M Stud Bolt Setters 6(1.0), 8(1.25), 10(1.5), 12(1.75)

4203MF	4 Pieces Set/△=530g
METAL CASE:W130×H65×T26mm	
Stud Bolt Setter	
	4103M Stud Bolt Setters 6(1.0), 8(1.25), 10(1.25), 12(1.25)

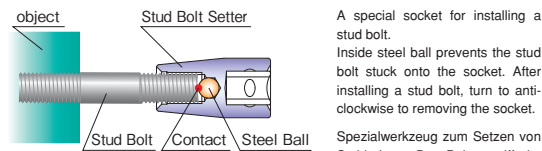

A special socket for installing a stud bolt.
Inside steel ball prevents the stud bolt stuck onto the socket. After installing a stud bolt, turn to anti-clockwise to removing the socket.

Spezialwerkzeug zum Setzen von Stehbolzen. Der Bolzen trifft im Werkzeug nur auf den Stahlbolzen, was die Kontaktfläche verringert. Nach dem Setzen des Stehbolzens kann das Werkzeug im Linkslauf vom Stehbolzen abgezogen werden.

Douilles spéciales pour monter les goujons.
Le goujon est en contact avec une bille d'acier pour l'empêcher d'adhérer à la douille.
Après avoir posé le goujon, tourner dans le sens antihorlogique pour le retirer

13103M (mm)		D ₁ (mm)	D ₂ (mm)	ℓ (mm)	L (mm)	(g)	(pcs.)	
5(0.8)	3/8"	9.5	19	8	32	39	10	*1
6(1.0)		10.8	19	9	32	41	10	*1
7(1.0)		12.5	19	10	32	44	10	*1
8(1.25)		13.5	19	11	35	49	10	*1
10(1.25)		15.8	19	13	35	49	10	*1
10(1.5)		15.8	19	13	35	49	10	*1

*1 C-Ring=1301C, Pin/O-Ring=1301A/B → P250-251

14103M (mm)		D ₁ (mm)	D ₂ (mm)	ℓ (mm)	L (mm)	(g)	(pcs.)	
6(1.0)	1/2"	12	25	11	42	75	10	*1
7(1.0)		13.2	25	12	42	78	10	*1
8(1.25)		14.5	25	15	42	81	10	*1
10(1.25)		17	25	18	49	106	10	*1
10(1.5)		17	25	18	49	106	10	*1
12(1.25)		19.5	25	19	49	107	10	*1
12(1.75)		19.5	25	19	49	107	10	*1
14(1.5)		22	25	21	55	128	10	*1
14(2.0)	22	25	21	55	128	10	*1	

*1 C-Ring=1401C, Pin/O-Ring=1401A/B → P250-251

4103M Stud Bolt Setters
Stehbolzensetzer
Monte-goujons

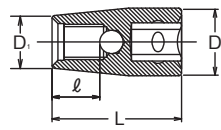

4203M Stud Bolt Setters Set
4203MF Stehbolzensetzer im Satz
Jeu de monte-goujons



13103M Impact Stud Bolt Setters
Impact Stehbolzensetzer
Monte-goujons Impact

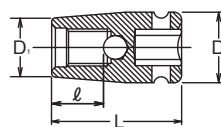

14103M Impact Stud Bolt Setters
Impact Stehbolzensetzer
Monte-goujons Impact

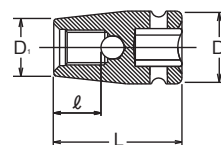

Z-SERIES
HAND
TITANIUM
ACCESSORIES
SCREWDRIVERS
IMPACT
SLEEVE-DRIVE
PROTECTOR
INDUSTRIAL
AUTOMOTIVE
MOTORCYCLE
CONSTRUCTION
SPARE PART

Tap Holder / Die Holder
 Halter für Gewindeschneider / Halter für Gewindeschneideisen
 Porte taraud / Porte-filière

Z-SERIES
 HAND
 TITANIUM
 ACCESSORIES
 SCREWDRIVERS
 IMPACT
 SLEEVE-DRIVE
 PROTECTOR
 INDUSTRIAL
 AUTOMOTIVE
 MOTORCYCLE
 CONSTRUCTION
 SPARE PART

3131A Adjustable Tap Holder
 Halter für Gewindeschneider, einstellbar
 Porte taraud, ajustable



3131A	□	S(mm)		L (mm)	⚖ (g)	📦 (pcs.)
		Min.	Max.			
1	3/8"	2.0	5.0	42	80	5
2	3/8"	4.5	8.0	47	100	5

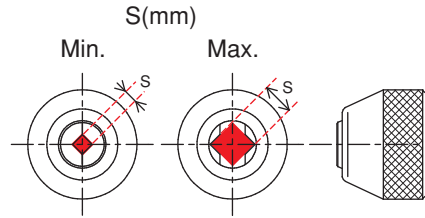

160K Reversible Ratchet
 Verstellbare Knarre
 Cliquet réversible

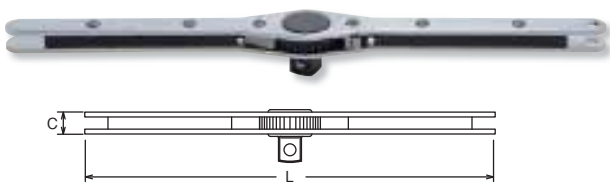

Tap is not included.
 Gewindeschneider, nicht enthalten.
 Taraud non inclus.

	□	C (mm)	L (mm)	⚖ (g)	📦 (pcs.)
160K	3/8"	10	220	130	1
160K-1/2	1/2"	10	220	135	1

3132 Die Holder
 Halter für Gewindeschneideisen
 Porte-filière

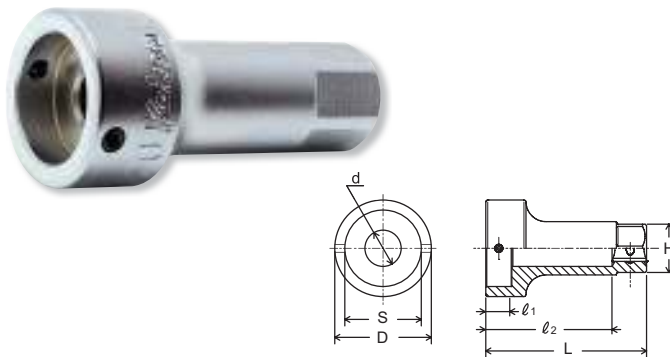

	□	S (mm)	D (mm)	d (mm)	H (mm)	l ₁ (mm)	l ₂ (mm)	L (mm)	⚖ (g)	📦 (pcs.)
3132-20	3/8"	20	28	8	17	7	46	60	130	5
4132-25	1/2"	25	34	14	22	9	42	60	170	2
New 4132-38	1/2"	38	48	18	24	13	60	80	315	2

4132 Die Holder
 Halter für Gewindeschneideisen
 Porte-filière



Die is not included.
 Gewindeschneideisen, nicht enthalten.
 Filière non inclus.

2127 (mm)		D ₁ (mm)	D ₂ (mm)	ℓ (mm)	L (mm)	(g)	(pcs.)
4	1/4"	7	13	4	23	14	10
4.5		7.4	13	4	23	14	10
5		8	13	5	23	14	10
5.5		8.8	13	5	23	14	10
6		9.5	13	6	23	14	10
7		10.9	13	6	23	14	10
8		11.5	13	8	23	14	10
9		13	13	8	23	15	10
9.5		13.8	13	10	23	16	10
10		14.8	13	10	23	17	10

RS2127/6	6 Pieces Set/Rail 150mm	(g)
4, 4.5, 5, 5.5, 6, 7		105

RS2127/10	10 Pieces Set/Rail 150mm	(g)
4, 4.5, 5, 5.5, 6, 7, 8, 9, 9.5, 10		180

3127 (mm)		D ₁ (mm)	D ₂ (mm)	ℓ (mm)	L (mm)	(g)	(pcs.)
8	3/8"	11.5	19	8	32	40	10
9		13	19	8	32	40	10
9.5		13.8	19	8	32	41	10
10		14.8	19	10	32	41	10
11		16	19	10	32	43	10
12		17	19	12	32	44	10
13		18.5	19	12	32	46	10
14		19.7	19	14	32	48	10
15		20.7	19	14	32	52	10
16		22.2	22	14	32	66	10
17	23.5	22	16	35	80	10	
19	26	22	16	35	92	10	

RS3127/8	8 Pieces Set/Rail 200mm	(g)
8, 9, 10, 11, 12, 13, 14, 16		420

3128-80 (mm)		D ₁ (mm)	D ₂ (mm)	ℓ (mm)	L (mm)	(g)	(pcs.)
8	3/8"	11.5	19	6	80	58	10
9		13	19	6	80	61	10
10		14.8	19	8	80	66	10
11		16	19	8	80	70	10
12		17	19	10	80	77	10
13		18.5	19	10	80	80	10
14		19.7	19	12	80	82	10

2127 NUTTWISTER®

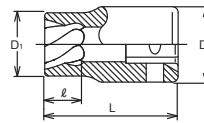

RS2127/6 Socket Set on Rail
Steckschlüsselsatz auf Schiene
Jeu de douilles sur rail



RS2127/10 Socket Set on Rail
Steckschlüsselsatz auf Schiene
Jeu de douilles sur rail



3127 NUTTWISTER®

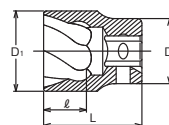

RS3127/8 Socket Set on Rail
Steckschlüsselsatz auf Schiene
Jeu de douilles sur rail



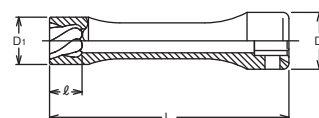

3128 (L80) NUTTWISTER® (Long type)

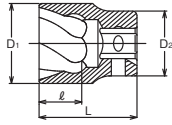

Z-SERIES
HAND
TITANIUM
ACCESSORIES
SCREWDRIVERS
IMPACT
SLEEVE-DRIVE
PROTECTOR
INDUSTRIAL
AUTOMOTIVE
MOTORCYCLE
CONSTRUCTION
SPARE PART

4127  NUTTWISTER®



4127 (mm)		D ₁ (mm)	D ₂ (mm)	ℓ (mm)	L (mm)	(g)	(pcs.)
14	1/2"	19.7	30	14	42	125	10
17		23.5	30	16	42	137	10
19		26	30	16	42	146	10
21		28	30	17	42	153	10
22		29.5	30	17	42	158	10
24		32	30	18	42	174	10
25.4		33.5	30	18	42	183	10

RS4127/6   Socket Set on Rail
Steckschlüsselsatz auf Schiene
Jeu de douilles sur rail



RS4127/6	6 Pieces Set/Rail 200mm	(g)
17, 19, 21, 22, 24, 25.4		960

4128 (L120)  NUTTWISTER® (Long type)

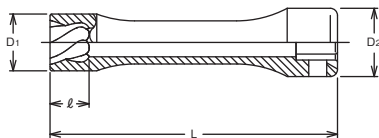

4128-120 (mm)		D ₁ (mm)	D ₂ (mm)	ℓ (mm)	L (mm)	(g)	(pcs.)
17	1/2"	23.5	30	16	120	227	10
19		26	30	16	120	247	10
21		28	30	17	120	262	10
22		29.5	30	17	120	259	10

A very effective method and easy solution for removing rounded off nuts, bolts and studs. The sharp edges of the NUTTWISTER® Socket opening will tighten around the nut, bolt or stud and turn it easily off.

Eine einfache und wirkungsvolle Methode rund gedrehte Muttern und Bolzen herausdrehen bzw. zu öffnen.
Die scharfen Kanten der gewundenen NUTTWISTER® Öffnung setzen sich um die Mutter bzw. den Schraubenkopf und drehen sie problemlos heraus.

Il existe une méthode simple mais efficace pour retirer les écrous et les boulons arrondis ainsi que les goujons et les dispositifs de verrouillage des jantes.
Les arêtes vives de la douille NUTTWISTER® vont «mordre» l'écrou, le boulon ou le goujon et permettre ainsi facilement son extraction.



3129-32 (mm)		D ₁ (mm)	D ₂ (mm)	L (mm)	(g)	(pcs.)
2	3/8"	2	19	32	32	10
3		3	19	32	33	10
4		4	19	32	33	10
6		6	19	32	35	10
8		8	19	32	37	10
10		10	19	32	40	10

3129-60 (mm)		D ₁ (mm)	D ₂ (mm)	L (mm)	(g)	(pcs.)
2	3/8"	2	19	60	38	10
3		3	19	60	42	10
4		4	19	60	44	10
6		6	19	60	47	10
8		8	19	60	53	10
10		10	19	60	64	10

RS3129/6-L32	6 Pieces Set/Rail 150mm	(g)
2, 3, 4, 6, 8, 10		250

RS3129/6-L60	6 Pieces Set/Rail 150mm	(g)
2, 3, 4, 6, 8, 10		320

4129-37 (mm)		D ₁ (mm)	D ₂ (mm)	L (mm)	(g)	(pcs.)
8	1/2"	8	24	37	59	10
10		10	24	37	63	10
12		12	24	37	67	10
14		14	24	37	72	10
16		16	24	37	78	10

4129-75 (mm)		D ₁ (mm)	D ₂ (mm)	L (mm)	(g)	(pcs.)
8	1/2"	8	24	75	80	10
10		10	24	75	94	10
12		12	24	75	110	10
14		14	24	75	130	10
16		16	24	75	150	10

RS4129/5-L37	5 Pieces Set/Rail 150mm	(g)
8, 10, 12, 14, 16		370

RS4129/5-L75	5 Pieces Set/Rail 150mm	(g)
8, 10, 12, 14, 16		600



3129-32/-60 BOLTTWISTER®

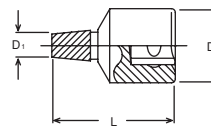

RS3129/6-L32/-L60

Socket Set on Rail
Steckschlüsselsatz auf Schiene
Jeu de douilles sur rail



4129-37/-75 BOLTTWISTER®

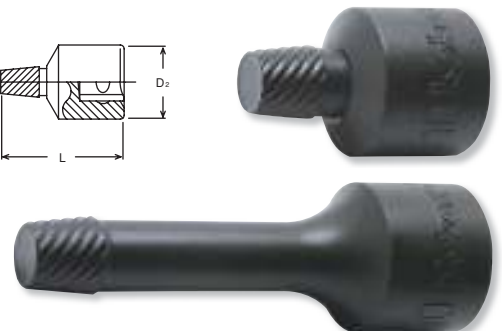
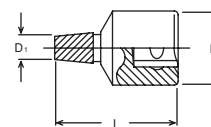

RS4129/5-L37/-L75

Socket Set on Rail
Steckschlüsselsatz auf Schiene
Jeu de douilles sur rail

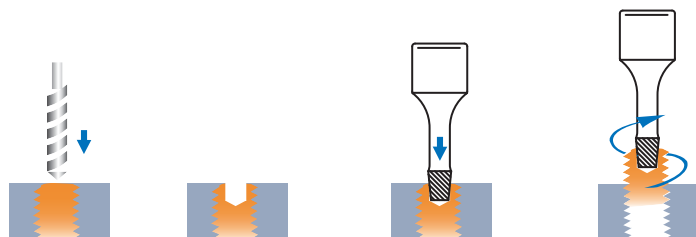

Effective method and easy solution for removing twisted off bolt. Drill a hole in the center of bolt and drive BOLTTWISTER® firmly into the hole. The sharp spiral edges will hold the broken bolt and easily remove it.

BOLTTWISTER	Bolt size	Drill size
2	M5	φ 2.4 ~ 2.6
3	M6	φ 3.2 ~ 3.5
4	M8	φ 4.2 ~ 4.5
6	M10 ~ M12	φ 6.2 ~ 6.5
8	M14 ~ M16	φ 8.2 ~ 8.5
10	M18 ~ M20	φ 10.2 ~ 10.5
12	M22 ~ M24	φ 12.2 ~ 12.5
14	M27 ~ M30	φ 14.2 ~ 14.5
16	M33	φ 16.2 ~ 16.5

Ratcheting Ring Spanners



Knarren-Ringschlüssel

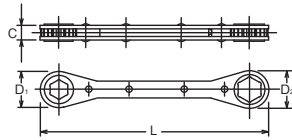

Clés hexagonales à cliquet

Z-SERIES
HAND
TITANIUM
ACCESSORIES
SCREWDRIVERS
IMPACT
SLEEVE-DRIVE
PROTECTOR
INDUSTRIAL
AUTOMOTIVE
MOTORCYCLE
CONSTRUCTION
SPARE PART

102NM / 102NA Without reverse lever Nicht umstellbar Non réversible





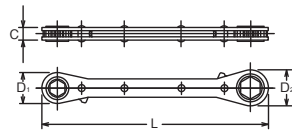

102NM (mm)	L (mm)	D ₁ (mm)	D ₂ (mm)	C (mm)	 (g)	 (pcs.)
6x7	108	15.3	16.4	7.5	60	10
7x8	108	15.3	16.4	7.5	60	10
8x9	134	17.1	19.7	7.5	80	10
8x10	134	17.1	19.7	7.5	80	10
10x11	140	20.1	22.7	7.5	87	10
10x12	140	20.1	22.7	7.5	87	10
New 11x13	145	23.6	24.6	9	112	10
12x13	145	23.6	24.6	9	112	10
12x14	145	23.6	24.6	9	112	10

102NA (inch)	L (mm)	D ₁ (mm)	D ₂ (mm)	C (mm)	 (g)	 (pcs.)
7/32 x 1/4	108	15.3	16.4	7.5	60	10
1/4 x 9/32	108	15.3	16.4	7.5	60	10
1/4 x 5/16	108	15.3	16.4	7.5	60	10
5/16 x 11/32	134	17.1	19.7	7.5	80	10
5/16 x 3/8	134	17.1	19.7	7.5	80	10
3/8 x 7/16	140	20.1	22.7	7.5	87	10
7/16 x 1/2	145	23.6	24.6	9	112	10
1/2 x 9/16	145	23.6	24.6	9	112	5

102KM / 102KA Reversible Umstellbar Réversible





102KM (mm)	L (mm)	D ₁ (mm)	D ₂ (mm)	C (mm)	 (g)	 (pcs.)
6x7	108	15.3	16.4	7.2	51	10
7x8	108	15.3	16.4	7.2	51	10
8x9	134	17	20	9.1	76	10
8x10	134	17	20	9.1	76	10
10x11	141	21	23.5	9.1	84	10
10x12	141	21	23.5	9.1	84	10
12x13	146	24	25	9.1	89	10
12x14	146	24	25	9.1	89	5
13x17	200	27.1	31.8	11.5	190	5
14x17	200	27.1	31.8	11.5	200	5

102KA (inch)	L (mm)	D ₁ (mm)	D ₂ (mm)	C (mm)	 (g)	 (pcs.)
7/32 x 1/4	108	15.3	16.4	7.2	51	10
1/4 x 5/16	108	15.3	16.4	7.2	51	10
New 5/16 x 11/32	134	17	20	9	76	10
3/8 x 7/16	141	21	23.5	9.1	84	10
1/2 x 9/16	146	24	25	9.1	89	5

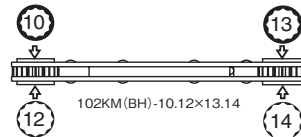

102KM (BH) With Twin Openings (Two-in-One) Doppel-Ringschlüssel (zwei Öffnungen in einer) Ouvertures doubles



102KM-BH (mm)	L (mm)	D ₁ (mm)	D ₂ (mm)	C (mm)	 (g)	 (pcs.)
5.5- 6x 7- 8	108	15.3	16.4	10	60	10
8 ·10x12·13	141	21	23.5	13	87	10
9 ·10x11·12	141	21	23.5	13	87	10
10 ·12x13·14	146	24	25	13	98	10
13 ·14x15·17	200	27.1	31.8	16	200	5

102KT Reversible TORX® Umstellbar TORX® Réversible TORX®



102KT (E)	L (mm)	D ₁ (mm)	D ₂ (mm)	C (mm)	 (g)	 (pcs.)
E 4xE 6	108	15.3	16.4	7.5	51	10
E 6xE 8	108	15.3	16.4	7.5	51	10
E10xE12	134	17	20	9	76	10

103KM (mm)	L (mm)	D ₁ (mm)	D ₂ (mm)	C (mm)	(g)	(pcs.)
6x 7	108	15.3	16.4	7.5	51	5
7x 8	108	15.3	16.4	7.5	51	5
8x 9	134	17	20	9	76	5
8x10	134	17	20	9	76	5
10x11	140	21	23.5	9	84	5
10x12	140	21	23.5	9	84	5
12x13	145	24	25	9	89	5
12x14	145	24	25	9	89	5

103KA (inch)	L (mm)	D ₁ (mm)	D ₂ (mm)	C (mm)	(g)	(pcs.)
7/32x 1/4	108	15.3	16.4	7.5	51	5
1/4 x 5/16	108	15.3	16.4	7.5	51	5
5/16x11/32	134	17	20	9	76	5
5/16x 3/8	134	17	20	9	76	5
3/8 x 7/16	140	21	23.5	9	84	5
7/16x 1/2	145	24	25	9	89	5
1/2 x 9/16	145	24	25	9	89	5

103KA.BH (inch)	L (mm)	D ₁ (mm)	D ₂ (mm)	C (mm)	(g)	(pcs.)
1/4x5/16	108	15.3	16.4	7.5	51	5
3/8x7/16	140	21	23.5	9	84	5
1/2x9/16	145	24	25	9	89	5

103KT (E)	L (mm)	D ₁ (mm)	D ₂ (mm)	C (mm)	(g)	(pcs.)
E 4xE 6	104	15.3	16.4	7.5	51	5
E 6xE 8	104	15.3	16.4	7.5	51	5
E10xE12	128	17	20	9	76	5
E14xE16	139	24	25	9	89	5

145KM (mm)	L (mm)	D (mm)	C (mm)	(g)	(pcs.)
10H	125	20.1	7.5	72	10



150-10H (mm)	D (mm)	ℓ (mm)	L (mm)	(g)	(pcs.)
5	12	3.5	11	6	10
6	12	4.5	12.5	7	10
7	12	5	14	7	10
8	12	6	15.5	7	10
9	13	6	16	7	10
10	14.3	7	17	9	10
12	17.4	9	19.5	14	10

1203		7 Pieces Set/△=250g
METAL CASE:W130xH65xT20mm		
Sockets		Accessory
150.10H 5, 6, 7, 8, 9, 10	145KM-10H	

103KM / 103KA ○ Reversible
Umstellbar
Réversible

103KA.BH ○ Reversible (12P)
Umstellbar (12P)
Réversible (12P)

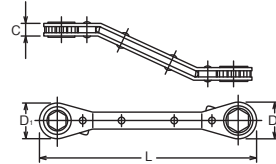

103KT ○ Reversible TORX®
Umstellbar TORX®
Réversible TORX®

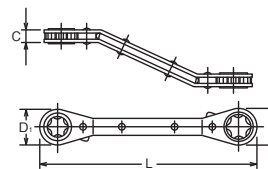

145KM-10H ○ Reversible, 10mm 6-pt.
Verstellbar SW10mm
Réversible 10mm

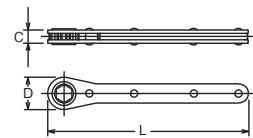

150-10H ○ Sockets with 10mm 6-point Drive End
Steckschlüssel mit 10mm Sechskant-Antrieb
Douilles à conducteur de 10mm 6-pans mâle

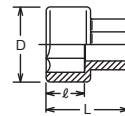

1203 ○ Sockets with 10mm 6-point Drive End in Set with Ratchet
Steckschlüssel mit 10mm Sechskant-Antrieb mit Knarre im Satz
Jeu de douilles à conducteur 10mm 6-pans mâle, avec cliquet





Ratcheting Ring Spanners
 Knarren-Ringschlüssel
 Clés hexagonales à cliquet

Z-SERIES
 HAND
 TITANIUM
 ACCESSORIES
 SCREWDRIVERS
 IMPACT
 SLEEVE-DRIVE
 PROTECTOR
 INDUSTRIAL
 AUTOMOTIVE
 MOTORCYCLE
 CONSTRUCTION
 SPARE PART

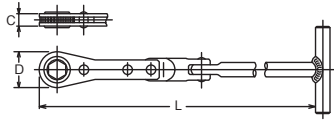

154M  Push and Pull-Ratchets
 Hub-Knarren
 Clé à cliquet de levage



154M (mm)	L (mm)	D (mm)	C (mm)	 (g)	 (pcs.)
8	294	17.1	7.5	178	2
10	297	20.1	7.5	183	2
12	300	23.6	9	189	2
13	301	24.6	9	194	2
14	301	24.6	9	194	2



154ML  Push and Pull-Ratchets
 Hub-Knarren
 Clé à cliquet de levage

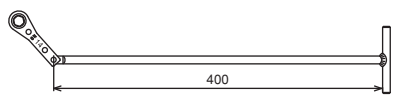

154ML (mm)	L (mm)	D (mm)	C (mm)	 (g)	 (pcs.)
10	297	20.1	7.5	230	2
12	300	23.6	9	252	2

1206  Push and Pull-Ratchet
 Hub-Knarre
 Clé à cliquet de levage



1206		3 Pieces Set/  =320g
CARDBOARD BOX		
Sockets		Accessory
 150.14H Sockets 12, 14	154K-14	



Ratcheting Ring Spanners Knarren-Ringschlüssel Clés hexagonales à cliquet

137	L (mm)	D ₁ (mm)	D ₂ (mm)	C (mm)	(g)	(pcs.)
	141	23.5	21	9	104	5

1/4" × 3/8"

138	L (mm)	D ₁ (mm)	D ₂ (mm)	C (mm)	(g)	(pcs.)
	141	23.5	21	9	97	10

1/4" × 1/4"

139	L (mm)	D (mm)	C (mm)	(g)	(pcs.)
	125	20.1	7.5	80	10

1/4"

R810 (inch)	L (mm)	D ₁ (mm)	D ₂ (mm)	C (mm)	(g)	(pcs.)
1/4×5/16	108	15.3	16.4	7.5	60	10
3/8×7/16	140	20.1	22.7	7.5	87	10
1/2×9/16	145	23.6	24.6	9	112	10

137  For 1/4" and 3/8" Square Drive Sockets
Für Steckschlüssel mit 1/4" und 3/8" Antrieb
Pour douilles d'un carré conducteur de 1/4" et 3/8"

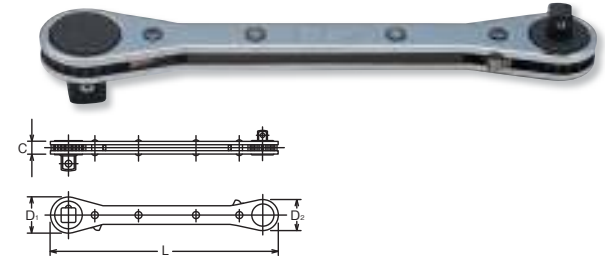

138  For Bits 101
Für Klängen 101
Pour embouts 101

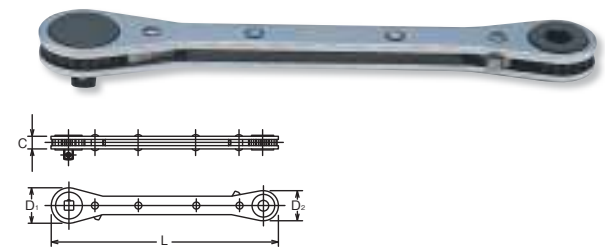

139  For 1/4" Square Drive Sockets
Für Steckschlüssel mit 1/4" Antrieb
Pour douilles d'un carré conducteur de 1/4"

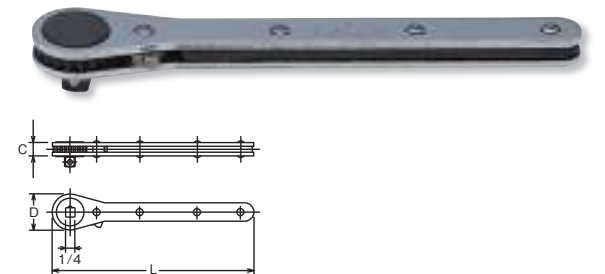

R810  Reversible (12P)
Umstellbar (12P)
Réversible (12P)

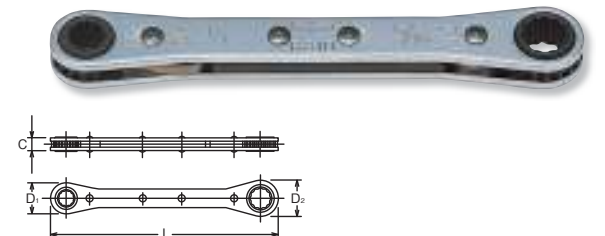

Z-SERIES
HAND
TITANIUM
ACCESSORIES
SCREWDRIVERS
IMPACT
SLEEVE-DRIVE
PROTECTOR
INDUSTRIAL
AUTOMOTIVE
MOTORCYCLE
CONSTRUCTION
SPARE PART

Ratcheting Ring Spanners

Knarren-Ringschlüssel

Clés hexagonales à cliquet

Z-SERIES
HAND
TITANIUM
ACCESSORIES
SCREWDRIVERS
IMPACT
SLEEVE-DRIVE
PROTECTOR
INDUSTRIAL
AUTOMOTIVE
MOTORCYCLE
CONSTRUCTION
SPARE PART

101P PH Bits PH Bits Embouts, PH

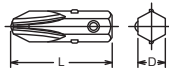

101P (PH)	D (mm)	L (mm)	(g)	(pcs.)
1	6.35	20.5	3	10
2	6.35	20.5	4	10
3	6.35	20.5	5	10

101S Slotted Bits Schlitz Bits Embouts, fente

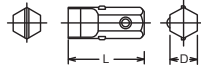

101S	D (mm)	L (mm)	(g)	(pcs.)
1.0x7	6.35	15	3	10
1.2x7	6.35	15	3	10

101H Hex Bits Sechskant Bits Embouts, 6 pans creux

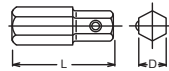

101H (mm)	D (mm)	L (mm)	(g)	(pcs.)
3	6.35	20.5	5	10
4	6.35	20.5	5	10
5	6.35	20.5	5	10
6	6.35	20.5	5	10
7	6.35	20.5	6	10
8	6.35	20.5	7	10

101B Ball-point Hex Bits Sechskant Bits Embouts, 6 pans creux

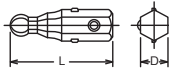

101B (mm)	D (mm)	L (mm)	(g)	(pcs.)
3	6.35	25	4	10
4	6.35	25	4	10
5	6.35	25	5	10
6	6.35	25	5	10

 Ball point bits have less strength due to the special design. Make sure to use them correctly.

101T (T) TORX® Bits TORX® Bits Embouts, TORX®

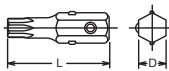

101T (T)	D (mm)	L (mm)	(g)	(pcs.)
T 9	6.35	25	4	10
T10	6.35	25	4	10
T15	6.35	25	5	10
T20	6.35	25	5	10
T25	6.35	25	5	10
T27	6.35	25	6	10
T30	6.35	25	6	10

101T (TH) Tamper-Resistant TORX® Bits TORX® Bits Embouts, TORX®

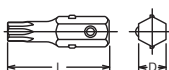

101T (TH)	D (mm)	L (mm)	(g)	(pcs.)
T10H	6.35	25	4	10
T15H	6.35	25	4	10
T20H	6.35	25	5	10
T25H	6.35	25	5	10
T27H	6.35	25	6	10
T30H	6.35	25	6	10

 Tamper Resistant TORX® Bits have less strength due to special design. Make sure to use it correctly.

128H (mm)	D (mm)	L (mm)	(g)	(pcs.)
3	8	32	11	10
4	8	32	11	10
5	8	32	12	10
6	8	32	12	10
8	8	32	13	10

128T (T)	D (mm)	L (mm)	(g)	(pcs.)
T10	8	32	9	10
T15	8	32	9	10
T20	8	32	9	10
T25	8	32	10	10
T27	8	32	10	10
T30	8	32	11	10

101A	D (mm)	S (mm)	L (mm)	(g)	(pcs.)
	8	6.35	20	8	10

128H Hex Bits
Sechskant Bits
Embouts, 6 pans creux

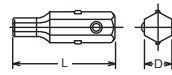

128T TORX® Bits
TORX® Bits
Embouts, TORX®

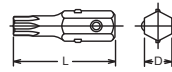



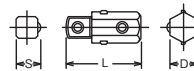

101A Adaptor
Verbindungsstück
Adaptateur

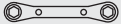

1202		15 Pieces Set/△=420g
METAL CASE:W190xH60xT30mm		
Bits	Accessory	
<p>101P Phillips Bits 1, 2, 3</p> <p>101S Slotted Bit 1x7</p> <p>101B Ballpoint Hex Bits 3, 4, 5, 6</p> <p>101T TORX® Bits T10, T15, T20, T25, T27, T30</p>	 138	

1202 Bit Set
Bit-Satz
Jeu d'embouts



2254M		12 Pieces Set/△=450g
METAL CASE:W160xH100xT28mm		
Bits	Accessories	
<p>101P Phillips Bits 1, 2, 3</p> <p>101S Slotted Bits 1x7, 1.2x7</p> <p>101H Hex Bits 3, 4, 5</p>	 102NA-1/4x5/16  2769F  101A  2137	

2254M Bit Set
Bit-Satz
Jeu d'embouts



Ratcheting Ring Spanners Knarren-Ringschlüssel Clés hexagonales à cliquet

Z-SERIES
HAND
TITANIUM
ACCESSORIES
SCREWDRIVERS
IMPACT
SLEEVE-DRIVE
PROTECTOR
INDUSTRIAL
AUTOMOTIVE
MOTORCYCLE
CONSTRUCTION
SPARE PART

R810A Bit Set
Bit-Satz
Jeu d'embouts



R810A 5 Pieces Set/△=208g	
METAL CASE:W130xH65xT20mm	
Bits	Accessory
<ul style="list-style-type: none"> 101P Phillips Bits 1, 2, 3 101S Slotted Bit 1x7 	 102NA-1/4x5/16



R810B Bit Set
Bit-Satz
Jeu d'embouts



R810B 10 Pieces Set/△=268g	
METAL CASE:W130xH65xT20mm	
Bits	Accessory
<ul style="list-style-type: none"> 101P Phillips Bits 1, 2, 3 101S Slotted Bit 1x7 128H Hex Bits 3, 4, 5, 6, 8 	 102NA-1/4x5/16

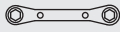

R810C Bit and Socket Set
Bit und Steckschlüssel Satz
Jeu de douilles et d'embouts



R810C 12 Pieces Set/△=227g	
METAL CASE:W130xH65xT20mm	
Bits, Sockets	Accessories
<ul style="list-style-type: none"> 101P Phillips Bits 1, 2, 3 101S Slotted Bit 1x7 2400M Sockets 5, 6, 7, 8, 9, 10 	 102NA-1/4x5/16  101A

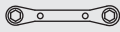

R810D Bit and Socket Set
Bit und Steckschlüssel Satz
Jeu de douilles et d'embouts



R810D 17 Pieces Set/△=336g	
METAL CASE:W130xH65xT20mm	
Bits, Sockets	Accessories
<ul style="list-style-type: none"> 101P Phillips Bits 1, 2, 3 101S Slotted Bit 1x7 128H Hex Bits 3, 4, 5, 6, 8 2400M Sockets 5, 6, 7, 8, 9, 10 	 102NA-1/4x5/16  101A

R810E Socket Set
Steckschlüssel Satz
Jeu de clés à douilles

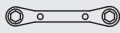

R810E 9 Pieces Set/△=445g	
METAL CASE:W130xH65xT20mm	
Sockets	Accessories
<ul style="list-style-type: none"> 2300M Deep Sockets 6, 7, 8, 9, 10, 11, 12 	 102NA-1/4x5/16  101A



156M  6-Point Deep
6-kant, lang
Longues 6-pans

156M (mm)	D (mm)	ℓ (mm)	H (mm)	L ₁ (mm)	L ₂ (mm)	(g)	(pce.)
8	12	9	41	355	200	231	1
10	14.5	11	41	355	200	289	1
12	16.8	13	41	355	200	429	1
14	20	16	41	355	200	454	1

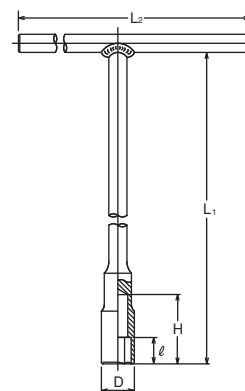

104ME/104A  6-Point
6-kant
6-pans

104ME (mm)	D (mm)	ℓ (mm)	L ₁ (mm)	L ₂ (mm)	(g)	(pce.)
6	9.5	8	200	180	150	1
7	11	9	200	180	152	1
8	12	10	250	200	183	1
9	14	12	250	200	188	1
10	14	13	250	200	230	1
11	16	14	250	200	234	1
12	18	15	250	200	355	1
13	18.5	17	250	250	390	1
14	20	18	250	250	399	1
15	21	19	250	250	404	1
16	22.5	21	250	250	419	1
17	24	22	250	250	568	1
18	25	23	250	250	577	1
19	26.5	25	250	250	594	1

104A (inch)	D (mm)	ℓ (mm)	L ₁ (mm)	L ₂ (mm)	(g)	(pce.)
1/4	9.5	8	200	180	150	1
5/16	12	10	250	200	183	1
3/8	14	12	250	200	188	1
7/16	16	14	250	200	234	1
1/2	18.5	17	300	250	412	1
9/16	20	18	300	250	428	1
5/8	22.5	21	350	300	528	1
3/4	26.5	25	350	300	717	1

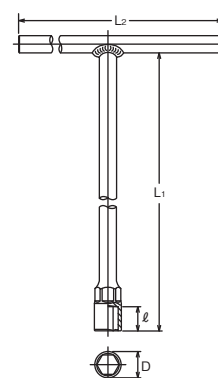

Z-SERIES
HAND
TITANIUM
ACCESSORIES
SCREWDRIVERS
IMPACT
SLEEVE-DRIVE
PROTECTOR
INDUSTRIAL
AUTOMOTIVE
MOTORCYCLE
CONSTRUCTION
SPARE PART

3116M  Universal with 6-point Socket
Gelenk mit 6-kant Steckschlüssel
Cardan avec douille 6-pans



124M-600 (2B)

 Ball Joint plus Nut Grip Socket
Kugelgelenk mit 2-facher Kugelhalterung
Douilles articulées avec deux billes de retenue

3116M (mm)	D (mm)	ℓ (mm)	L ₁ (mm)	L ₂ (mm)	(g)	(pce.)
10	14.5	8	800	190	796	1
12	17	10.3	800	190	797	1
13	18	11.3	800	190	797	1
14	19.5	11.3	800	190	797	1
15	21	12.8	800	190	799	1
16	22	12.8	800	190	806	1
17	23.6	13.8	800	190	801	1
18	24	13.8	800	190	809	1

124M-600 (mm)	D (mm)	ℓ (mm)	L ₁ (mm)	L ₂ (mm)	(g)	(pce.)
8(2B)	12	5	600	200	332	1
10(2B)	14.5	6	600	200	334	1
12(2B)	16.8	7	600	200	424	1
13(2B)	18	8	600	200	425	1
14(2B)	19.5	8.5	600	200	527	1
17(2B)	23.3	9.5	600	200	538	1

NUT GRIP®

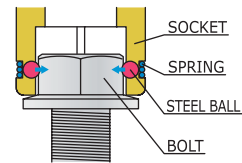

NUT GRIP®

Twin balls at the 6-point opening hold bolt/nut tightly for safe and reliable work.
Die zwei Kugeln in der 6-kant Öffnung unserer NUT GRIP Steckschlüssel halten die Schraube sicher im Steckschlüssel. Dies erlaubt ein Arbeiten auch an schwer zugänglichen Stellen.
Les 2 billes dans l'ouverture du 6-pans de la douille retiennent l'écrou de manière sûre et efficace.

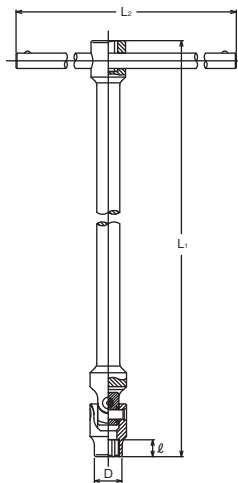



photo: 3116M

157HE  For Inhex Screws
Für Innensechskant-Schrauben
Pour vis à 6-pans creux

157HE (mm)	L ₁ (mm)	L ₂ (mm)	(g)	(pce.)
3	250	180	98	1
4	250	180	121	1
5	250	180	158	1
6	250	180	416	1
8	250	180	422	1
10	300	190	440	1
12	320	210	660	1

157T  For TORX® Screws
Für TORX®-Schrauben
Pour vis TORX®

157T (T)	L ₁ (mm)	L ₂ (mm)	(g)	(pce.)
T25	250	180	95	1
T27	250	180	96	1
T30	250	180	167	1
T40	250	180	168	1
T45	250	180	213	1
T50	250	180	215	1

157S  For Slotted Heads
Für Schlitzschrauben
Pour vis à fente

157S	T×W	L ₁ (mm)	L ₂ (mm)	(g)	(pce.)
6	1.0×6	200	180	84	1
8	1.2×8	250	180	170	1

157PE  For Phillips Screws
Für Kreuzschlitzschrauben, Phillips
Pour vis à empreinte Phillips

157PE (PH)	L ₁ (mm)	L ₂ (mm)	(g)	(pce.)
2	250	180	95	1
3	250	180	170	1

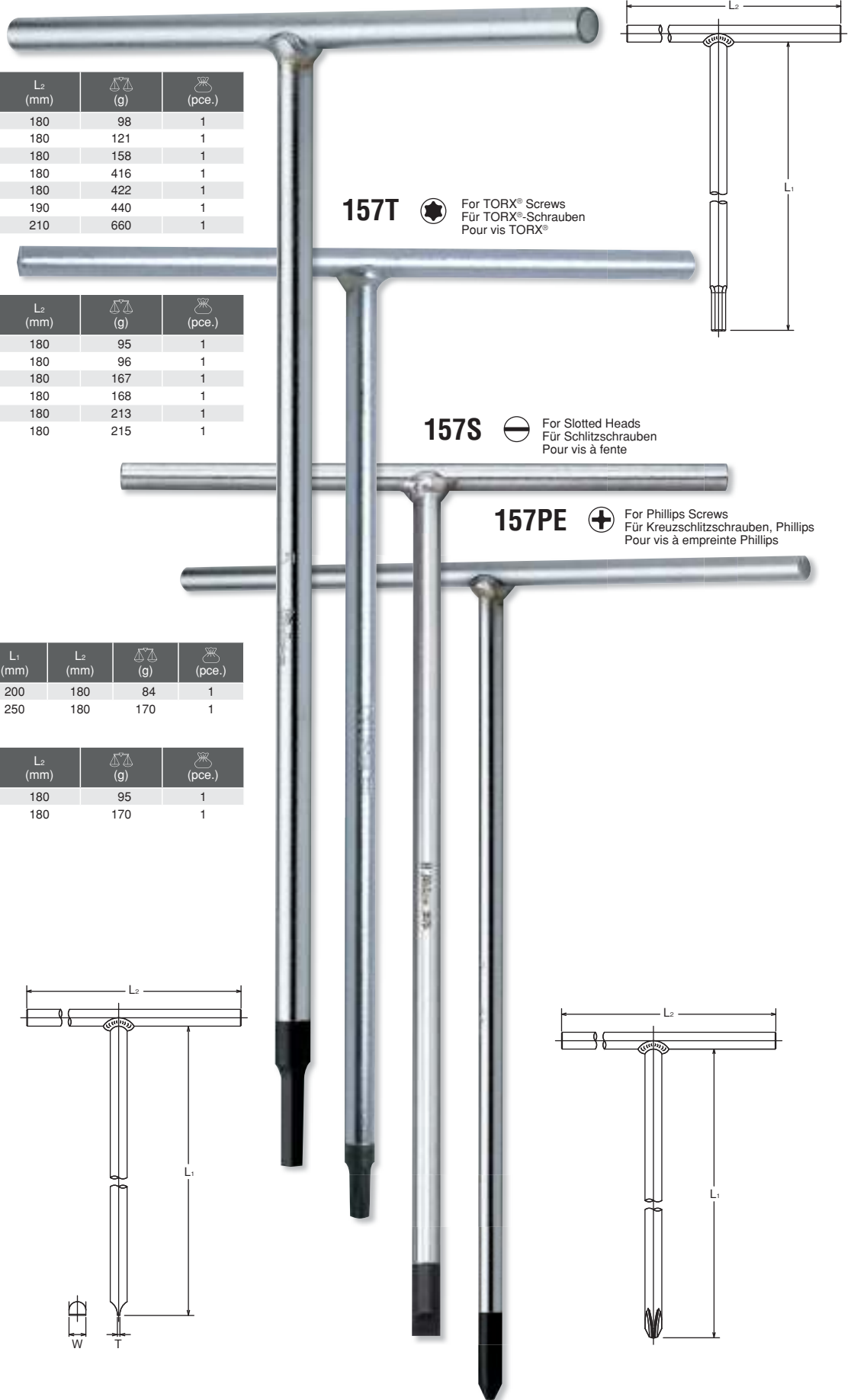

T-Handles
T-Griffe
Poignées en T

Z-SERIES
HAND
TITANIUM
ACCESSORIES
SCREWDRIVERS
IMPACT
SLEEVE-DRIVE
PROTECTOR
INDUSTRIAL
AUTOMOTIVE
MOTORCYCLE
CONSTRUCTION
SPARE PART

2715  T-Handle
T-Griff
Poignée coulissante



3715  T-Handle
T-Griff
Poignée coulissante



3715S  T-Handle
T-Griff
Poignée coulissante



3715SL  T-Handle
T-Griff
Poignée coulissante



3715SLK  T-Handle
T-Griff
Poignée coulissante



3716  T-Handle
T-Griff
Poignée coulissante 

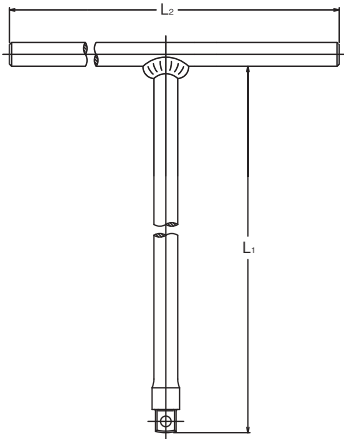

		L ₁ (mm)	L ₂ (mm)	 (g)	 (pce.)
2715		200	120	130	1





		L ₁ (mm)	L ₂ (mm)	 (g)	 (pce.)
3715		268	240	386	1
3715S		268	190	347	1
3715SL		237	200	325	1
3715SLK		236	200	470	1
3716		268	240	379	1



photo: 3715SLK

2715/3715/3716
This tool is used sockets in hard to reach places. 3716 has a reduced square drive and similar function as offset extension bars.



4715  T-Handle
T-Griff
Poignée coulissante







4715S  T-Handle
T-Griff
Poignée coulissante

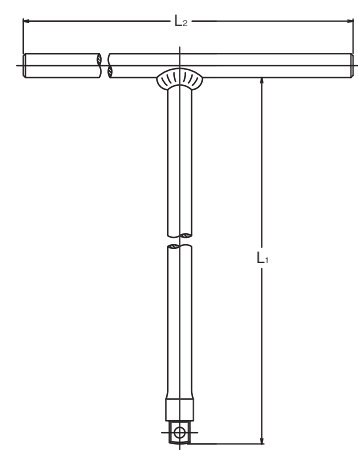





4715SL  T-Handle
T-Griff
Poignée coulissante

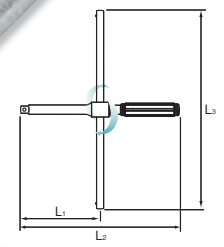
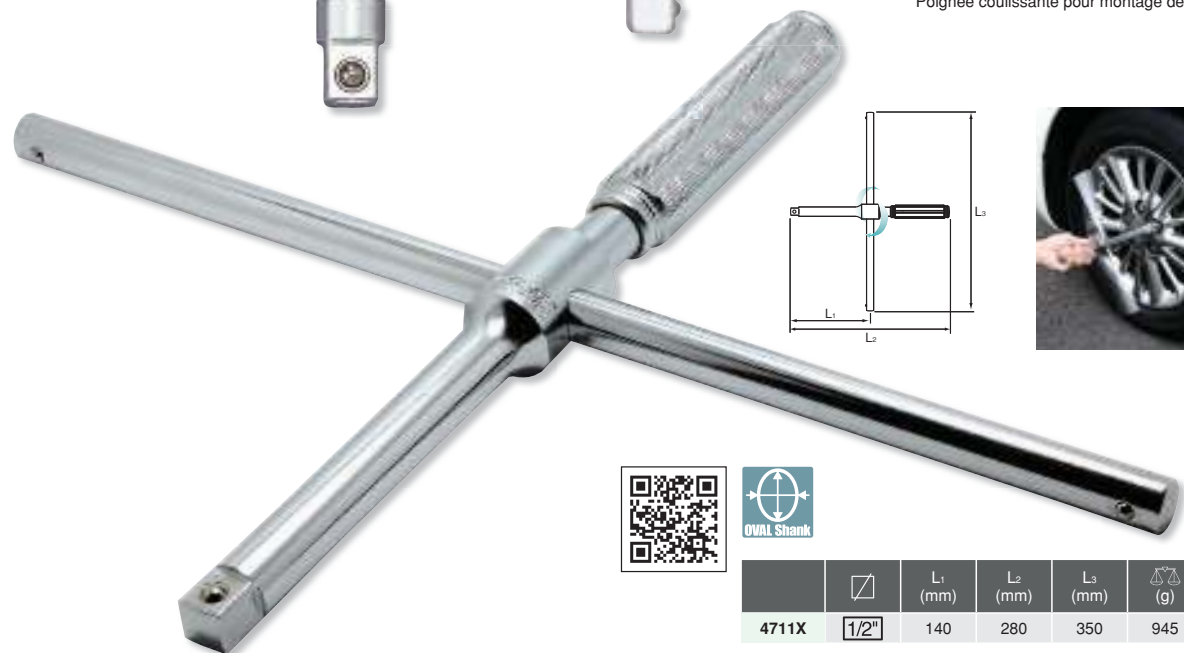

		L ₁ (mm)	L ₂ (mm)	 (g)	 (pce.)
4715		267	255	475	1
4715S		267	170	402	1
4715SL		250	250	640	1

4711X  Spinning cross wrench
T-Griff für die Radmuttermontage
Poignée coulissante pour montage des écrous à roue



		L ₁ (mm)	L ₂ (mm)	L ₃ (mm)	 (g)	 (pce.)
4711X		140	280	350	945	1

Attack Drivers

Hand-Schlagschrauber

Tournevis à frapper

Z-SERIES
HAND
TITANIUM
ACCESSORIES
SCREWDRIVERS
IMPACT
SLEEVE-DRIVE
PROTECTOR
INDUSTRIAL
AUTOMOTIVE
MOTORCYCLE
CONSTRUCTION
SPARE PART

3112G Attack Driver
Hand-Schlagschrauber
Tournevis à frapper



	□	L (mm)	⚖ (g)	📦 (pce.)
3112G	3/8"	159	810	1

* Renewal Kits → **3112RK** → P301

4112G Attack Driver
Hand-Schlagschrauber
Tournevis à frapper



	□	L (mm)	⚖ (g)	📦 (pce.)
4112G	1/2"	163	810	1
4112N	1/2"	163	730	1

* Renewal Kits → **4112RK** → P301

4112N Attack Driver
Hand-Schlagschrauber
Tournevis à frapper



	□	L (mm)	⚖ (g)	📦 (pce.)
6112	3/4"	190	1900	1





* Renewal Kits → **6112RK** → P301

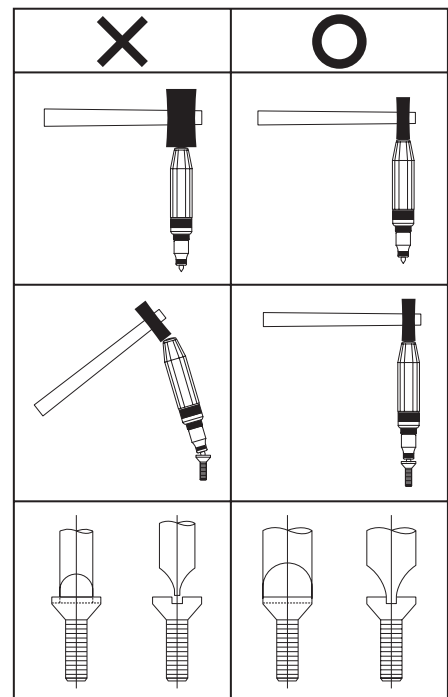

Black finished striking head prevents the problem of peeling.
Das geschwärzte Schlagende vermeidet das Abspringen von Chromteilen.
La finition "black finish" de la tête évite l'écaillage du au chromage.







6112 Attack Driver
Hand-Schlagschrauber
Tournevis à frapper



AG112A 6 Pieces Set/△=1,150g	
METAL CASE:W220xH82xT60mm	
Bits	Accessories
 100P.32 Phillips Bits 2, 3	 4112G
 100S.32 Slotted Bits 9, 11	 4138







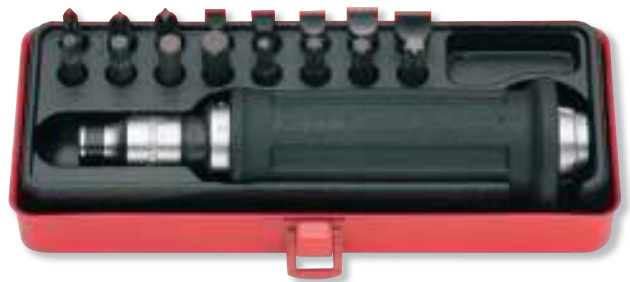

AG112A Attack Driver Set
Hand-Schlagschrauber-Satz
Jeu de tournevis à frapper



AG112H 18 Pieces Set/△=1,480g	
METAL CASE:W220xH82xT60mm	
Bits	Accessories
 100P.32 Phillips Bits 2, 3, 4	 4112G
 100S.32 Slotted Bits 8, 9, 10, 12, 14	 4138
 100H.32 Hex Bits 5, 6, 8, 10	
 100T.32 TORX® Bits T30, T40, T45, T50	





AG112H Attack Driver Set
Hand-Schlagschrauber-Satz
Jeu de tournevis à frapper



AG112F 25 Pieces Set/△=1,530g	
METAL CASE:W220xH82xT60mm	
Bits	Accessories
 100P.32 Phillips Bits 2, 3	 4112G
 100P.32 PZ Bits PZ2, PZ3	 4138
 100S.32 Slotted Bits 9, 11	
 100H.32 Hex Bits 4, 5, 6, 7, 8, 10	
 100T.32 TORX® Bits T25, T27, T30, T40, T45, T50	
 100X.32 XZN Bits M5, M6, M8, M10, M12	





AG112F Attack Driver Set
Hand-Schlagschrauber-Satz
Jeu de tournevis à frapper



AN112A 6 Pieces Set/△=1,070g	
METAL CASE:W190xH59xT45mm	
Bits	Accessories
 100P.32 Phillips Bits 2, 3	 4112N
 100S.32 Slotted Bits 9, 11	 4138

AN112A Attack Driver Set
Hand-Schlagschrauber-Satz
Jeu de tournevis à frapper



AN112C 8 Pieces Set/△=1,350g	
METAL CASE:W220xH82xT60mm	
Bits	Accessories
 100P.80 Phillips Bits 1, 2, 3	 4112N
 100S.80 Slotted Bits 7, 9, 12	 4138

AN112C Attack Driver Set
Hand-Schlagschrauber-Satz
Jeu de tournevis à frapper



DIN3126 C6.3
DIN3126 C8

1/4" 5/16"

Z-SERIES
HAND
TITANIUM
ACCESSORIES
SCREWDRIVERS
IMPACT
SLEEVE-DRIVE
PROTECTOR
INDUSTRIAL
AUTOMOTIVE
MOTORCYCLE
CONSTRUCTION
SPARE PART

2749P-1/4HF ○ Reversible Ratchet, for Bits 1/4"
Knarre, verstellbar, für Bits 1/4"
Cliquet, réversible pour embouts 1/4"



	D (mm)	H (mm)	L (mm)	(g)	(pcs.)
2749P-1/4HF	25	12	125	96	10
2774P-1/4HF	25	12	165	133	2

For DIN3126 C6.3 Bits
Für DIN3126 C6.3 Bits
Pour DIN3126 C6.3 Embouts

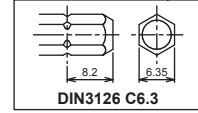

2774P-1/4HF ○ Flexible Ratchet, reversible, for Bits 1/4"
Gelenk-Knarre, verstellbar, für Bits 1/4"
Cliquet à tête articulée pour embouts 1/4"

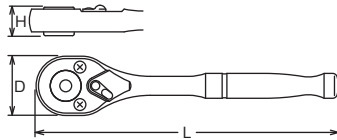

2749P-5/16HF ○ Reversible Ratchet, for Bits 5/16"
Knarre, verstellbar für Bits 5/16"
Cliquet, réversible pour embouts 5/16"



	D (mm)	H (mm)	L (mm)	(g)	(pcs.)
2749P-5/16HF	25	14	125	96	10
2774P-5/16HF	25	14	165	133	2

For DIN3126 C8 Bits
Für DIN3126 C8 Bits
Pour DIN3126 C8 Embouts

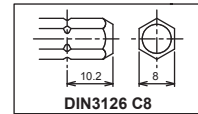

2774P-5/16HF ○ Flexible Ratchet, reversible, for Bits 5/16"
Gelenk-Knarre, verstellbar, für Bits 5/16"
Cliquet à tête articulée pour embouts 5/16"

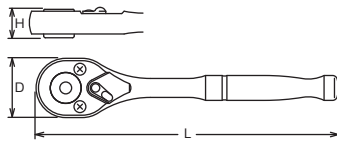

180M-50 ○ Bit Holder with Magnet
Klingenhalter mit Magnet
Porte-embouts avec aimant



	D (mm)	ℓ (mm)	L (mm)	(g)	(pcs.)
180M-50	11	13.5	50	15	10

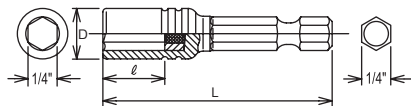

5/16"

Double ended Bits
Doppelseitige Bits
Embouts bilatéraux

131P-80	+	D (mm)	L (mm)	(g)	(pcs.)
1	No.1xNo.2	8	80	28	10
2	No.2xNo.3	8	80	29	10
3	No.3xNo.3	8	80	29	10

131P-80

PH Bits
PH Bits
Embouts, PH



131S-80	TxW (mm)	D (mm)	L (mm)	(g)	(pcs.)
6	1.0x6	8	80	29	10
7	1.0x7	8	80	29	10
8	1.2x8	8	80	30	10
9	1.6x9	8	80	31	10

131S-80

Slotted Bits
Schlitz Bits
Embouts, fente

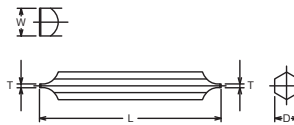

131T-80 (T)	D (mm)	L (mm)	(g)	(pcs.)
T10xT15	8	80	27	10
T20xT25	8	80	27	10
T27xT30	8	80	28	10

131T-80

TORX® Bits
TORX® Bits
Embouts, TORX®



	□	D ₁ (mm)	D ₂ (mm)	L (mm)	(g)	(pcs.)
3141	3/8"	16	18	48	60	10
4141	1/2"	16	22	52	70	10

3141

Bit Holder, extra deep for 131P-80, 131S-80, 131T-80
Klingenhalter, extra tief für 131P-80, 131S-80, 131T-80
Porte embouts, ouverture longue pour 131P-80, 131S-80, 131T-80

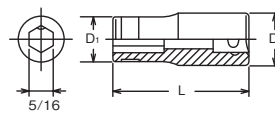

4141

Bit Holder, extra deep for 131P-80, 131S-80, 131T-80
Klingenhalter, extra tief für 131P-80, 131S-80, 131T-80
Porte embouts, ouverture longue pour 131P-80, 131S-80, 131T-80

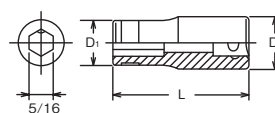

108P-25/-32/-50

 PH Bits
PH Bits
Embouts, PH

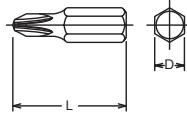

108S-25/-39

 Slotted Bits
Schlitz Bits
Embouts, fente

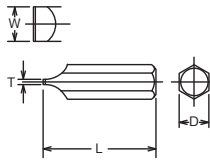

108H-25

 Hex Bits
Sechskant Bits
Embouts, 6 pans creux

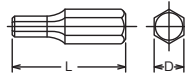

108T-25 (T)

 TORX® Bits
TORX® Bits
Embouts, TORX®

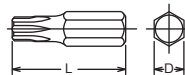

108T-25 (TH)

 Tamper-Resistant TORX® Bits
Tamper-Resistant TORX® Bits
Embouts TORX®, Tamper-Resistant 

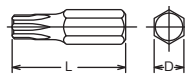

 Tamper Resistant TORX® Bits have less strength due to special design.
Make sure to use it correctly.

108A

 Adaptor
Verbindungsstück
Adaptateur

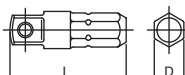

108P-25 (PH)	D (mm)	L (mm)	(g)	(pcs.)
1	6.35	25	5	10
2	6.35	25	5	10
3	6.35	25	6	10

108P-32 (PH)	D (mm)	L (mm)	(g)	(pcs.)
1	6.35	32	7	10
2	6.35	32	7	10
3	6.35	32	8	10

108P-50 (PH)	D (mm)	L (mm)	(g)	(pcs.)
1	6.35	50	10	10
2	6.35	50	11	10
3	6.35	50	11	10

108S-25	TxW (mm)	D (mm)	L (mm)	(g)	(pcs.)
3	0.5x3	6.35	25	3	10
4	0.6x4	6.35	25	3	10
4.5	0.6x4.5	6.35	25	4	10
5	0.8x5	6.35	25	5	10
5.5	0.8x5.5	6.35	25	5	10
6	1.0x6	6.35	25	5	10
8	1.2x8	6.35	25	6	10

108S-39	TxW (mm)	D (mm)	L (mm)	(g)	(pcs.)
3	0.5x3	6.35	39	6	10
4	0.6x4	6.35	39	6	10
4.5	0.6x4.5	6.35	39	6	10
5	0.8x5	6.35	39	7	10
5.5	0.8x5.5	6.35	39	8	10
6	1.0x6	6.35	39	9	10
8	1.2x8	6.35	39	12	10

108H-25 (mm)	D (mm)	L (mm)	(g)	(pcs.)
3	6.35	25	4	10
4	6.35	25	5	10
5	6.35	25	5	10
6	6.35	25	6	10
7	6.35	25	7	10
8	6.35	25	8	10
10	6.35	25	11	10

108H-25 (inch)	D (mm)	L (mm)	(g)	(pcs.)
1/8	6.35	25	4	10
9/64	6.35	25	5	10
New 5/32	6.35	25	5	10
3/16	6.35	25	5	10
7/32	6.35	25	6	10
1/4	6.35	25	7	10

108T-25 (T)	D (mm)	L (mm)	(g)	(pcs.)
New T 8	6.35	25	4	10
T10	6.35	25	4	10
T15	6.35	25	4	10
T20	6.35	25	5	10
T25	6.35	25	6	10
T27	6.35	25	6	10
T30	6.35	25	6	10
T40	6.35	25	6	10

108T-25 (TH)	D (mm)	L (mm)	(g)	(pcs.)
T10H	6.35	25	4	10
T15H	6.35	25	4	10
T20H	6.35	25	5	10
T25H	6.35	25	6	10
T27H	6.35	25	6	10
T30H	6.35	25	6	10
T40H	6.35	25	6	10

108A-25	D (mm)	L (mm)	(g)	(pcs.)
1/4B	6.35	25	10	10

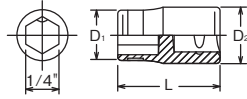

	□	D ₁ (mm)	D ₂ (mm)	L (mm)	(g)	(pcs.)
2137	1/4"	12	12	22.5	13	10
3137	3/8"	13	16.5	30	30	10
4137	1/2"	13	22	38	53	10

For DIN3126 C6.3 Bits
Für DIN3126 C6.3 Bits
Pour DIN3126 C6.3 Embouts

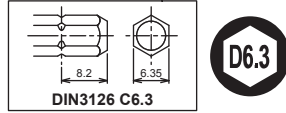

2137 ○ Bit Holder
Klingenhalter
Porte-embouts



3137 ○ Bit Holder
Klingenhalter
Porte-embouts



4137 ○ Bit Holder
Klingenhalter
Porte-embouts



12139 ○ Impact Bit Holder
Impact Klingenhalter
Porte embouts Impact



13139 ○ Impact Bit Holder
Impact Klingenhalter
Porte embouts Impact



14139 ○ Impact Bit Holder
Impact Klingenhalter
Porte embouts Impact



	□	D ₁ (mm)	D ₂ (mm)	L (mm)	(g)	(pcs.)	⚡
12139	1/4"	11	13	25	15	10	*1
13139	3/8"	11	19	30	32	10	*2
14139	1/2"	11	25	35	62	10	*3

*1 Pin/O-Ring=1200A/B
*2 C-Ring=1301C,Pin/O-Ring=1301A/B
*3 C-Ring=1401C,Pin/O-Ring=1401A/B

→ P250-251

For DIN3126 C6.3 Bits
Für DIN3126 C6.3 Bits
Pour DIN3126 C6.3 Embouts

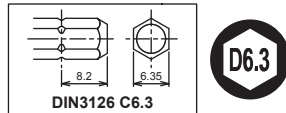

13142-D6.3 ○ Impact Bit Holder
Impact Klingenhalter
Porte embouts Impact



14142-D6.3 ○ Impact Bit Holder
Impact Klingenhalter
Porte embouts Impact



	□	D ₁ (mm)	D ₂ (mm)	L (mm)	(g)	(pcs.)	⚡
13142-D6.3	3/8"	16	19	45	60	10	*1
14142-D6.3	1/2"	16	25	55	97	10	*2

*1 C-Ring=1301C,Pin/O-Ring=1301A/B
*2 C-Ring=1401C,Pin/O-Ring=1401A/B

→ P250-251

For DIN3126 C6.3 Bits
Für DIN3126 C6.3 Bits
Pour DIN3126 C6.3 Embouts

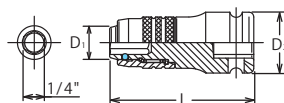
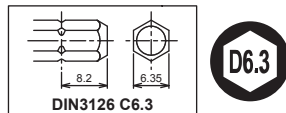

Lock & Quick Release

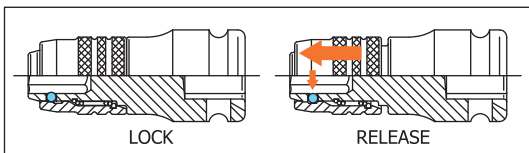

Z-SERIES
HAND
TITANIUM
ACCESSORIES
SCREWDRIVERS
IMPACT
SLEEVE-DRIVE
PROTECTOR
INDUSTRIAL
AUTOMOTIVE
MOTORCYCLE
CONSTRUCTION
SPARE PART

100P-32/-80/-125

PH Bits
PH Bits
Embouts, PH

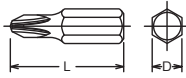

100P-32 (PH)	D (mm)	L (mm)	(g)	(pcs.)
1	8	32	11	10
2	8	32	11	10
3	8	32	12	10
4	8	32	12	10

100P-80 (PH)	D (mm)	L (mm)	(g)	(pcs.)
1	8	80	30	10
2	8	80	30	10
3	8	80	31	10
4	8	80	32	10

100P-125 (PH)	D (mm)	L (mm)	(g)	(pcs.)
2	8	125	48	10
3	8	125	49	10

100P-32 (PZ)

PZ Bits
PZ Bits
Embouts, PZ

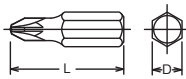

100P-32 (PZ)	D (mm)	L (mm)	(g)	(pcs.)
PZ2	8	32	10	10
PZ3	8	32	11	10

100S-32/-80

Slotted Bits
Schlitz Bits
Embouts, fente

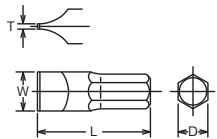

100S-32	TxW (mm)	D (mm)	L (mm)	(g)	(pcs.)
6	1 x 6	8	32	10	10
7	1 x 7	8	32	11	10
8	1.2x 8	8	32	12	10
9	1.6x 9	8	32	12	10
10	1.6x10	8	32	13	10
11	1.6x11	8	32	15	10
12	2 x12	8	32	18	10
14	2 x14	8	32	21	10

100S-80	TxW (mm)	D (mm)	L (mm)	(g)	(pcs.)
6	1 x 6	8	80	29	10
7	1 x 7	8	80	30	10
8	1.2x 8	8	80	31	10
9	1.6x 9	8	80	32	10
10	1.6x10	8	80	33	10
11	1.6x11	8	80	33	10
12	2 x12	8	80	34	10
14	2 x14	8	80	37	10

100H-32

Hex Bits
Sechskant Bits
Embouts, 6 pans creux

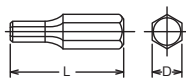

100H-32 (mm)	D (mm)	L (mm)	(g)	(pcs.)
3	8	32	11	10
4	8	32	11	10
5	8	32	12	10
6	8	32	12	10
7	8	32	13	10
8	8	32	13	10
New 9	8	32	16	10
New 10	8	32	16	10
11	8	32	20	10
12	8	32	23	10
14	8	32	29	10

100T-32 (T)

TORX® Bits
TORX® Bits
Embouts, TORX®

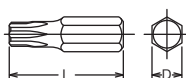

100T-32 (T)	D (mm)	L (mm)	(g)	(pcs.)
T10	8	32	9	10
T15	8	32	9	10
T20	8	32	9	10
T25	8	32	10	10
T27	8	32	10	10
T30	8	32	11	10
T40	8	32	12	10
T45	8	32	12	10
T50	8	32	12	10
T55	8	32	12	10

100T-32 (TH)	D (mm)	L (mm)	(g)	(pcs.)
T10H	8	32	9	10
T15H	8	32	9	10
T20H	8	32	9	10
T25H	8	32	10	10
T27H	8	32	10	10
T30H	8	32	11	10
T40H	8	32	12	10
T45H	8	32	12	10
T50H	8	32	12	10
T55H	8	32	12	10

100X-32	D (mm)	L (mm)	(g)	(pcs.)
M 5	8	32	10	10
M 6	8	32	11	10
M 8	8	32	12	10
M10	8	32	16	10
M12	8	32	19	10

		D ₁ (mm)	D ₂ (mm)	L (mm)	(g)	(pcs.)
2138	1/4"	16	16	26	32	10
3138	3/8"	16	18	38	55	10
4138	1/2"	16	22	38	62	10

For DIN3126 C8 Bits
Für DIN3126 C8 Bits
Pour DIN3126 C8 Embouts

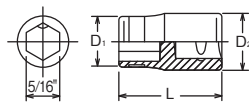
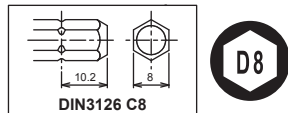

		D ₁ (mm)	D ₂ (mm)	L (mm)	(g)	(pcs.)	
12140	1/4"	14	13	25	15	10	*1
13140	3/8"	14	19	30	32	10	*2
14140	1/2"	14	25	35	62	10	*3

*1 Pin/O-Ring=1200A/B
*2 C-Ring=1301C,Pin/O-Ring=1301A/B
*3 C-Ring=1401C,Pin/O-Ring=1401A/B

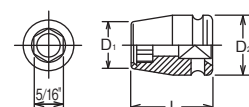
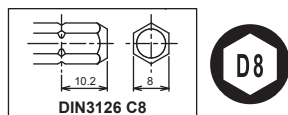

For DIN3126 C8 Bits
Für DIN3126 C8 Bits
Pour DIN3126 C8 Embouts

100T-32 (TH)

Tamper-Resistant TORX® Bits
Tamper-Resistant TORX® Bits
Embouts TORX®, Tamper-Resistant

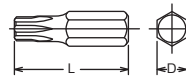

Tamper Resistant TORX® Bits have less strength due to special design.
Make sure to use it correctly.

100X-32 (XZN)

XZN Bits
XZN Bits
Embouts, XZN

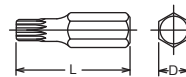

2138

Bit Holder
Klingenthaler
Porte-embouts



3138

Bit Holder
Klingenthaler
Porte-embouts



4138

Bit Holder
Klingenthaler
Porte-embouts



12140

Impact Bit Holder
Impact Klingenthaler
Porte embouts Impact



13140

Impact Bit Holder
Impact Klingenthaler
Porte embouts Impact



14140

Impact Bit Holder
Impact Klingenthaler
Porte embouts Impact



Z-SERIES
HAND
TITANIUM
ACCESSORIES
SCREWDRIVERS
IMPACT
SLEEVE-DRIVE
PROTECTOR
INDUSTRIAL
AUTOMOTIVE
CONSTRUCTION
MOTORCYCLE
SPARE PART

121P-50/-70/-100/-150

PH Bits
PH Bits
Embouts, PH

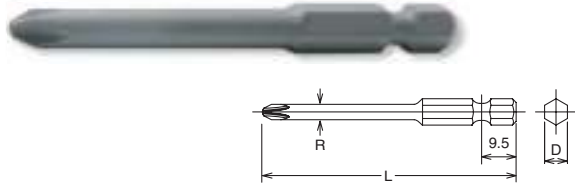

		D (mm)	R (mm)	L (mm)	(g)	(pcs.)
121P-50 (PH)	1	6.35	4.5	50	12	10
	2	6.35	5.5	50	12	10
	3	6.35	-	50	13	10
121P-70 (PH)	1	6.35	4.5	70	15	10
	2	6.35	5.5	70	15	10
	3	6.35	-	70	16	10
121P-100 (PH)	1	6.35	4.5	100	23	10
	2	6.35	5.5	100	23	10
	3	6.35	-	100	24	10
121P-150 (PH)	1	6.35	4.5	150	30	10
	2	6.35	5.5	150	35	10
	3	6.35	-	150	36	10

121H-50/-70/-100/-150

Hex Bits
Sechskant Bits
Embouts, 6 pans creux

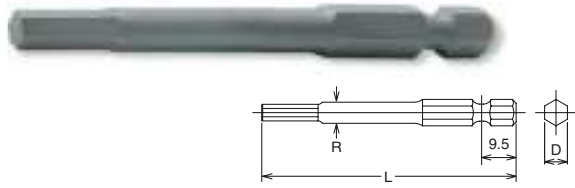

121H-50 (mm)	D (mm)	R (mm)	L (mm)	(g)	(pcs.)
New 2	6.35	4.0	50	11	10
2.5	6.35	3.0	50	12	10
3	6.35	3.5	50	12	10
4	6.35	4.5	50	12	10
5	6.35	5.6	50	13	10
6	6.35	-	50	14	10

		D (mm)	R (mm)	L (mm)	(g)	(pcs.)
New 121H-70 (mm)	2	6.35	4.0	70	13	10
	2.5	6.35	4.0	70	15	10
	3	6.35	4.0	70	15	10
	4	6.35	4.5	70	15	10
	5	6.35	5.6	70	16	10
	6	6.35	-	70	18	10
New 121H-100 (mm)	2	6.35	4.0	100	22	10
	2.5	6.35	4.0	100	23	10
	3	6.35	4.0	100	23	10
	4	6.35	4.5	100	23	10
	5	6.35	5.6	100	24	10
	6	6.35	-	100	26	10
New 121H-150 (mm)	2	6.35	4.0	150	35	10
	2.5	6.35	4.0	150	35	10
	3	6.35	4.5	150	37	10
	4	6.35	5.0	150	37	10
	5	6.35	6.0	150	38	10
	6	6.35	-	150	39	10

121T-50/-70/-100/-150 (T)

TORX® Bits
TORX® Bits
Embouts, TORX®

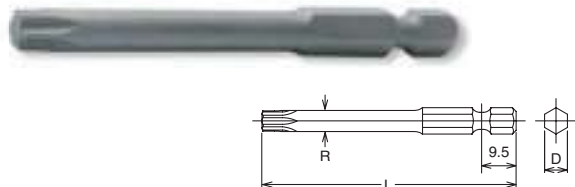

121T-50 (T)	D (mm)	R (mm)	L (mm)	(g)	(pcs.)
T10	6.35	3.0	50	12	10
T15	6.35	3.5	50	12	10
T20	6.35	4.1	50	12	10
T25	6.35	4.6	50	12	10
T27	6.35	5.2	50	13	10
T30	6.35	5.7	50	13	10
T40	6.35	-	50	14	10

		D (mm)	R (mm)	L (mm)	(g)	(pcs.)
121T-70 (T)	T10	6.35	3.5	70	16	10
	T15	6.35	3.5	70	16	10
	T20	6.35	4.1	70	16	10
	T25	6.35	4.6	70	16	10
	T27	6.35	5.2	70	17	10
	T30	6.35	5.7	70	17	10
	T40	6.35	-	70	18	10
	121T-100 (T)	T10	6.35	3.5	100	24
T15		6.35	4.0	100	24	10
T20		6.35	4.1	100	24	10
T25		6.35	4.6	100	24	10
T27		6.35	5.2	100	24	10
T30		6.35	5.7	100	25	10
T40		6.35	-	100	26	10
New 121T-150 (T)		T10	6.35	3.0	150	35
	T15	6.35	4.0	150	37	10
	T20	6.35	4.5	150	37	10
	T25	6.35	5.0	150	37	10
	T27	6.35	5.6	150	37	10
	T30	6.35	6.0	150	38	10
	T40	6.35	-	150	39	10

121T-70/-100 (TH)

Tamper-Resistant TORX® Bits
Tamper-Resistant TORX® Bits
Embouts TORX®, Tamper-Resistant

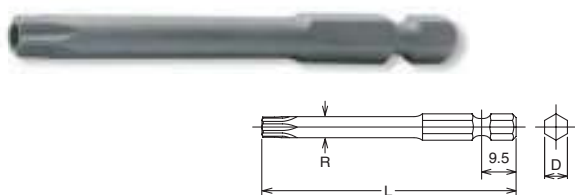

		D (mm)	R (mm)	L (mm)	(g)	(pcs.)
New 121T-70 (TH)	T15H	6.35	3.5	70	15	10
	T20H	6.35	4.1	70	16	10
	T25H	6.35	4.6	70	16	10
	T27H	6.35	5.2	70	17	10
	T30H	6.35	5.7	70	17	10
	T40H	6.35	-	70	18	10
New 121T-100 (TH)	T15H	6.35	3.5	100	22	10
	T20H	6.35	4.1	100	24	10
	T25H	6.35	4.6	100	24	10
	T27H	6.35	5.2	100	24	10
	T30H	6.35	5.7	100	25	10
	T40H	6.35	-	100	26	10

 Tamper Resistant TORX® Bits have less strength due to special design.
Make sure to use it correctly.

121T-50 (IP)	D (mm)	R (mm)	L (mm)	(g)	(pcs.)
20IP	6.35	4.1	50	12	10
25IP	6.35	4.6	50	12	10
27IP	6.35	5.2	50	13	10
30IP	6.35	5.7	50	13	10
40IP	6.35	-	50	14	10

121T-70 (IP)	D (mm)	R (mm)	L (mm)	(g)	(pcs.)
20IP	6.35	4.1	70	16	10
25IP	6.35	4.6	70	16	10
27IP	6.35	5.2	70	17	10
30IP	6.35	5.7	70	17	10
40IP	6.35	-	70	18	10

123P-75	D (mm)	L (mm)	(g)	(pcs.)
1	6.35	75	16	10
2	6.35	75	16	10
3	6.35	75	17	10

123P-100	D (mm)	L (mm)	(g)	(pcs.)
1	6.35	100	23	10
2	6.35	100	23	10
3	6.35	100	24	10

123PT (PH)	D (mm)	L (mm)	(g)	(pcs.)
2	6.35	75	18	10
2	6.35	100	24	10

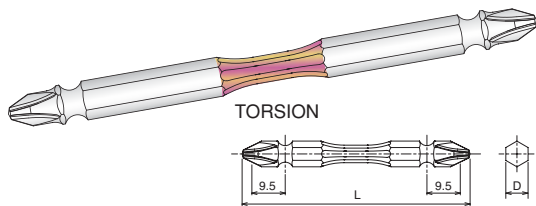

	□	D ₁ (mm)	D ₂ (mm)	L (mm)	(g)	(pcs.)	⚡
12137E	1/4"	12	13	36	22	10	*1
13137E	3/8"	12	19	40	40	10	*2
14137E	1/2"	12	25	48	70	10	*3

*1 Pin/O-Ring=1200A/B
 *2 C-Ring=1301C, Pin/O-Ring=1301A/B
 *3 C-Ring=1401C, Pin/O-Ring=1401A/B

→ P250-251

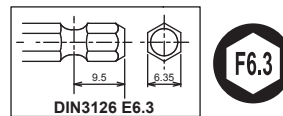

For DIN3126 E6.3 Bits
 Für DIN3126 E6.3 Bits
 Pour DIN3126 E6.3 Embouts

12137E, 13137E and 14147E can be used with various 1/4" bits, DIN 3126-C6.3, DIN 3126-E6.3 and Double ended type.

Die neuen Bithalter können für alle 1/4" Bits DIN 3126-C6.3, DIN 3126-E6.3 und für doppelseitige Bits verwendet werden.

Ces nouveaux porte embouts peuvent être utilisés avec tous les embouts 1/4" DIN 3126 E-6.3 et DIN 3126 C6.3

	□	D ₁ (mm)	D ₂ (mm)	L (mm)	(g)	(pcs.)	⚡
12142-F6.3	1/4"	16.5	13	36	22	10	*1
13142-F6.3	3/8"	16.5	19	45	60	10	*2
14142-F6.3	1/2"	16.5	25	55	100	10	*3

*1 Pin/O-Ring=1200A/B
 *2 C-Ring=1301C, Pin/O-Ring=1301A/B
 *3 C-Ring=1401C, Pin/O-Ring=1401A/B

→ P250-251

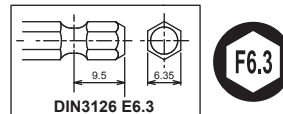

For DIN3126 E6.3 Bits
 Für DIN3126 E6.3 Bits
 Pour DIN3126 E6.3 Embouts

Lock & Quick Release

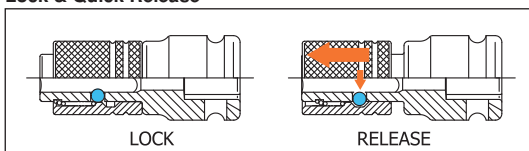

TORXplus is a registered trademark of Acument Intellectual Properties, LLC.
 TORXplus ist ein registriertes Markenzeichen der Firma Acument Intellectual Properties, LLC.
 TORXplus est une marque déposée de Acument Intellectual Properties, LLC.

121T-50/-70 (IP)



TORXPLUS® Bits
 TORXPLUS® Bits
 Embouts TORXPLUS®

TORXplus

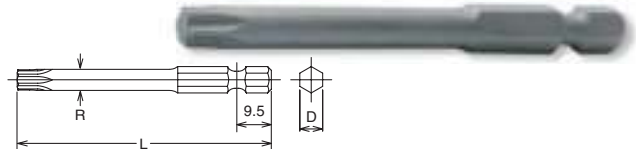

123P-75/-100



Double ended Bits, Phillips
 Doppelseitige bits, Phillips
 Embouts double face, Phillips

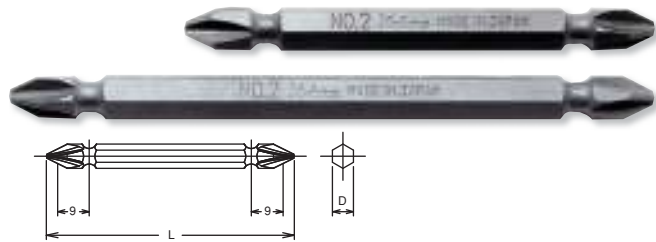

123PT-75/-100



Double ended Torsion Bits, Phillips
 Doppelseitige Torsionsbits, Phillips
 Embouts torsion double face, Phillips



12137E



Impact Bit Holder
 Impact Klingenhalter
 Porte embouts Impact

13137E

14137E

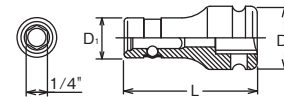

12142-F6.3



Impact Bit Holder (Quick Release)
 Impact Klingenhalter (Quick Release)
 Porte embouts Impact (Quick Release)

13142-F6.3

14142-F6.3

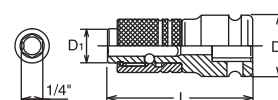

Nut Setters Steckschlüssel Klingen Embouts pour écrous

DIN3126 E6.3

Z-SERIES
HAND
TITANIUM
ACCESSORIES
SCREWDRIVERS
IMPACT
SLEEVE-DRIVE
PROTECTOR
INDUSTRIAL
AUTOMOTIVE
MOTORCYCLE
CONSTRUCTION
SPARE PART

113 Nut Setters Steckschlüssel Klingen Embouts pour écrous

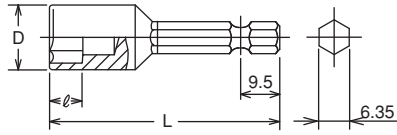

113 (mm)	D (mm)	l (mm)	L (mm)	(g)	(pcs.)
5.5	9	4	50	15	10
6	10	5	50	17	10
7	11	5	50	19	10
8	12	6	50	20	10
10	14.2	7	50	31	10
12	17	8	50	39	10
13	18	8	50	42	10
14	19	9	50	46	10

113 (inch)	D (mm)	l (mm)	L (mm)	(g)	(pcs.)
1/4	10	5	50	17	10
5/16	12	6	50	20	10
3/8	14.2	7	50	31	10
1/2	18	8	50	42	10

113 (E) Nut Setters, TORX® Steckschlüssel Klingen, TORX® Embouts pour écrous, TORX®

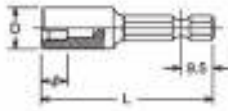

113 (E)	D (mm)	l (mm)	L (mm)	(g)	(pcs.)
E 4	6.1	4.5	50	12	10
E 5	7.5	4.5	50	15	10
E 6	8.3	5.0	50	17	10
E 7	8.8	5.8	50	18	10
E 8	10.1	6.6	50	19	10
E10	12	7.4	50	20	10

113-75/-100/-150/-200/-250 Nut Setters Steckschlüssel Klingen Embouts pour écrous

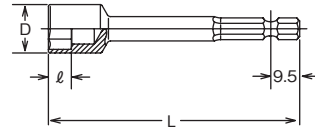

113-75 (mm)	D (mm)	l (mm)	L (mm)	(g)	(pcs.)
7	11.5	5	75	31	10
8	12.7	6	75	32	10
10	14.5	7	75	35	10
12	17	8	75	42	10
13	18	8	75	41	10
14	19	9	75	43	10

113-100 (mm)	D (mm)	l (mm)	L (mm)	(g)	(pcs.)
7	11.5	5	100	40	10
8	12.7	6	100	41	10
10	14.5	7	100	45	10
12	17	8	100	52	10
13	18	8	100	51	10
14	19	9	100	53	10

113-150 (mm)	D (mm)	l (mm)	L (mm)	(g)	(pcs.)
7	11.5	5	150	59	10
8	12.7	6	150	60	10
10	14.5	7	150	64	10
12	17	8	150	70	10
13	18	8	150	76	10
14	19	9	150	78	10

113-200 (mm)	D (mm)	l (mm)	L (mm)	(g)	(pcs.)
7	11.5	5	200	78	10
8	12.7	6	200	79	10
10	14.5	7	200	83	10
12	17	8	200	91	10
13	18	8	200	93	10
14	19	9	200	95	10

113-250 (mm)	D (mm)	l (mm)	L (mm)	(g)	(pcs.)
7	11.5	5	250	99	10
8	12.7	6	250	100	10
10	14.5	7	250	105	10
12	17	8	250	113	10
13	18	8	250	114	10
14	19	9	250	119	10

113UN-100/-150/-200 6-point Universal Joint Nut Setters 6-kant Steckschlüsselklingen mit Gelenk Douilles 6-pans universelles à embout

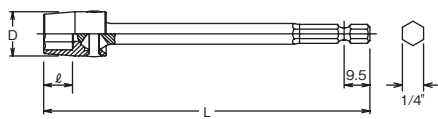

113UN-100 (mm)	D (mm)	l (mm)	L (mm)	(g)	(pcs.)
8	13	7	100	50	10
10	15	8	100	53	10
12	17	10	100	56	10
13	18	10	100	65	10
14	19.2	10	100	67	10

113UN-150 (mm)	D (mm)	l (mm)	L (mm)	(g)	(pcs.)
8	13	7	150	65	10
10	15	8	150	70	10
12	17	10	150	77	10
13	18	10	150	92	10
14	19.2	10	150	92	10

113UN-200 (mm)	D (mm)	l (mm)	L (mm)	(g)	(pcs.)
8	13	7	200	75	10
10	15	8	200	87	10
12	17	10	200	98	10
13	18	10	200	116	10
14	19.2	10	200	116	10

Nut Setters Steckschlüssel Klingen Embouts pour écrous DIN3126 E6.3

Z-SERIES HAND TITANIUM ACCESSORIES SCREWDRIVERS IMPACT SLEEVE-DRIVE PROTECTOR INDUSTRIAL AUTOMOTIVE MOTORCYCLE CONSTRUCTION SPARE PART

113-50 (mm)	D (mm)	ℓ (mm)	L (mm)	(g)	(pcs.)
7(2B)	11	5	50	20	10
8(2B)	12	6	50	21	10
10(2B)	14.2	7	50	26	10
13(2B)	18	8	50	31	10

113-50 (inch)	D (mm)	ℓ (mm)	L (mm)	(g)	(pcs.)
3/8(2B)	14.2	7	50	26	10

115 (mm)	D (mm)	ℓ (mm)	L (mm)	(g)	(pcs.)
5.5	9	2.1	50	15	10
6	10	2.4	50	17	10
7	11	2.8	50	19	10
8	12	3.5	50	20	10
10	14.2	4.2	50	29	10
12	17	5.6	50	40	10
13	18	6	50	50	10
14	19	6.4	50	60	10

115 (inch)	D (mm)	ℓ (mm)	L (mm)	(g)	(pcs.)
1/4	10	2.4	50	17	10
5/16	12	3.5	50	20	10
3/8	14.2	4.2	50	29	10
1/2	18	6	50	50	10

113-50 (2B)



Nut Setters, with 2 Balls
Steckschlüssel Klingen, mit 2-facher Kugelhalterung
Douilles à billes de retenue
Nut Grip®

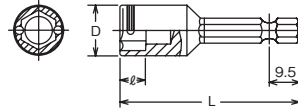

115



Nut Setters with Magnet
Steckschlüssel Klingen mit Magnet
Embouts avec aimant pour écrous

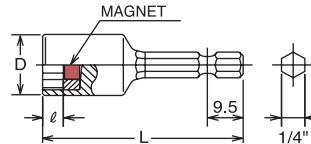

115-75/-100/-150/-200/-250



Nut Setters with Magnet
Steckschlüssel Klingen mit Magnet
Embouts avec aimant pour écrous

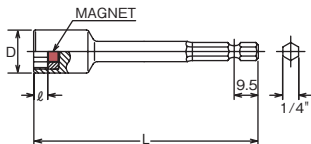

115-75 (mm)	D (mm)	ℓ (mm)	L (mm)	(g)	(pcs.)
7	11.5	2.8	75	32	10
8	12.7	3.5	75	33	10
10	14.5	4.2	75	38	10
12	17	5.6	75	46	10
13	18	6	75	49	10
14	19	6.4	75	52	10

115-150 (mm)	D (mm)	ℓ (mm)	L (mm)	(g)	(pcs.)
7	11.5	2.8	150	60	10
8	12.7	3.5	150	61	10
10	14.5	4.2	150	68	10
12	17	5.6	150	77	10
13	18	6	150	82	10
14	19	6.4	150	85	10

115-250 (mm)	D (mm)	ℓ (mm)	L (mm)	(g)	(pcs.)
7	11.5	2.8	250	101	10
8	12.7	3.5	250	103	10
10	14.5	4.2	250	110	10
12	17	5.6	250	118	10
13	18	6	250	122	10
14	19	6.4	250	124	10

115-100 (mm)	D (mm)	ℓ (mm)	L (mm)	(g)	(pcs.)
7	11.5	2.8	100	41	10
8	12.7	3.5	100	42	10
10	14.5	4.2	100	50	10
12	17	5.6	100	58	10
13	18	6	100	62	10
14	19	6.4	100	65	10

115-200 (mm)	D (mm)	ℓ (mm)	L (mm)	(g)	(pcs.)
7	11.5	2.8	200	79	10
8	12.7	3.5	200	80	10
10	14.5	4.2	200	88	10
12	17	5.6	200	97	10
13	18	6	200	102	10
14	19	6.4	200	105	10

Nut Setters
Steckschlüssel Klingen
Embouts pour écrous

DIN3126 E6.3
DIN3126 G7

115G-75/-100/-150/-200/-250

○ Nut Setters with sliding Magnet
Steckschlüssel Klingen mit versenkbarem Magnet
Embouts avec aimant, glissant pour écrous

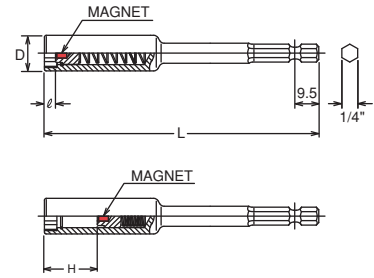

115G-75 (mm)	D (mm)	ℓ (mm)	H (mm)	L (mm)	(g)	(pcs.)
7	11.5	3.5	26	75	34	10
8	12.7	4	26	75	41	10
10	14.5	4.5	26	75	48	10
12	17	6	26	75	65	10
13	18	6.5	25	75	70	10
14	19	7	24	75	73	10

115G-150 (mm)	D (mm)	ℓ (mm)	H (mm)	L (mm)	(g)	(pcs.)
7	11.5	3.5	26	150	67	10
8	12.7	4	26	150	70	10
10	14.5	4.5	26	150	77	10
12	17	6	26	150	95	10
13	18	6.5	25	150	100	10
14	19	7	24	150	105	10

115G-100 (mm)	D (mm)	ℓ (mm)	H (mm)	L (mm)	(g)	(pcs.)
7	11.5	3.5	26	100	51	10
8	12.7	4	26	100	51	10
10	14.5	4.5	26	100	57	10
12	17	6	26	100	77	10
13	18	6.5	25	100	80	10
14	19	7	24	100	82	10

115G-200 (mm)	D (mm)	ℓ (mm)	H (mm)	L (mm)	(g)	(pcs.)
7	11.5	3.5	26	200	86	10
8	12.7	4	26	200	89	10
10	14.5	4.5	26	200	96	10
12	17	6	26	200	119	10
13	18	6.5	25	200	125	10
14	19	7	24	200	128	10

115G-250 (mm)	D (mm)	ℓ (mm)	H (mm)	L (mm)	(g)	(pcs.)
New 8	12.7	4	26	250	110	10
New 10	14.5	4.5	26	250	120	10
New 12	17	6	26	250	130	10

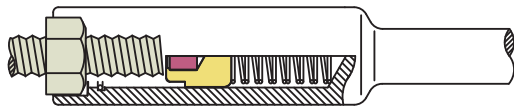

Sliding magnet system provides bolt clearance and magnetic function at the same time. The item 115G is mainly designed for assembly line work.

Die Steckschlüsselklinge mit versenkbarem Magnet bietet die Funktion eines Haltemagneten und genügend Freiraum für überstehende Bolzen. Dieses Werkzeug eignet sich vor allem für Montagearbeiten.

L'embout avec aimant glissant offre une fonction d'aimant et laisse assez d'espace pour des goujons surmontés. L'objet 115G a été conçu spécialement pour le travail d'assemblage.



119 ○ Nut Setters with Magnet
Steckschlüssel Klingen mit Magnet
Embouts avec aimant pour écrous

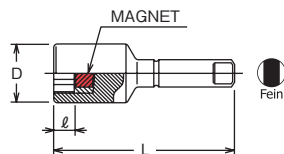

119 (mm)	D (mm)	ℓ (mm)	L (mm)	(g)	(pcs.)
5.5	9	2.1	50	17	10
6	10	2.4	50	20	10
7	11	2.8	50	22	10
8	12	3.5	50	23	10
10	14.2	4.2	50	30	10
12	17	5.6	50	42	10
13	18	6	50	52	10

119 (inch)	D (mm)	ℓ (mm)	L (mm)	(g)	(pcs.)
1/4	10	1.8	50	20	10
5/16	12	3.5	50	23	10
3/8	14.2	4.2	50	30	10

7/16"

DIN3126 E11.2

Z-SERIES
HAND
TITANIUM
ACCESSORIES
SCREWDRIVERS
IMPACT
SLEEVE-DRIVE
PROTECTOR
INDUSTRIAL
AUTOMOTIVE
MOTORCYCLE
CONSTRUCTION
SPARE PART

	183H-35 (inch)	L (mm)	(g)	(pcs.)
New	3/16	35	15	10
New	7/32	35	16	10
New	1/4	35	18	10
New	5/16	35	20	10
New	3/8	35	26	10
New	7/16	35	28	10
New	1/2	35	38	10

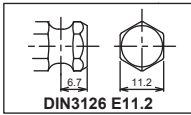

183H-35/-75/-150

Hex Bits
Sechskant Bits
Embout, 6 pans creux

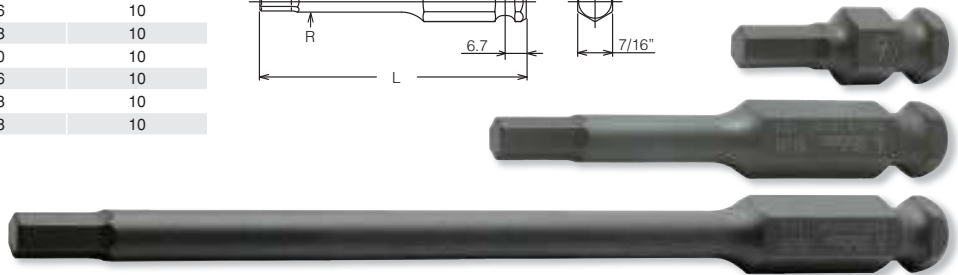
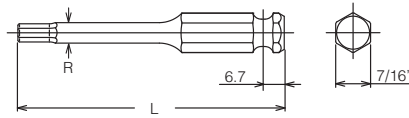

	183H-35 (mm)	L (mm)	(g)	(pcs.)
	3	35	15	10
	4	35	15	10
	5	35	15	10
	6	35	18	10
New	7	35	19	10
	8	35	20	10
	10	35	26	10
New	11	35	28	10
	12	35	30	10
	14	35	35	10
New	16	35	47	10
New	17	35	50	10
New	18	35	53	10
New	19	35	56	10

	183H-75 (mm)	L (mm)	R (mm)	(g)	(pcs.)
	3	75	6.0	34	10
	4	75	6.0	35	10
	5	75	6.5	36	10
	6	75	7.5	39	10
New	7	75	8.5	44	10
	8	75	9.5	47	10
	10	75	-	57	10
New	11	75	-	60	10
	12	75	-	65	10
	14	75	-	79	10

	183H-150 (mm)	L (mm)	R (mm)	(g)	(pcs.)
	4	150	6.0	51	10
	5	150	6.5	55	10
	6	150	7.5	65	10
	8	150	9.5	87	10
	10	150	-	118	10
	12	150	-	136	10

	183T-35 (T)	L (mm)	(g)	(pcs.)
New	T25	35	18	10
	T30	35	18	10
	T40	35	20	10
	T45	35	22	10
	T50	35	26	10
	T55	35	30	10
	T60	35	38	10

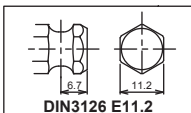

183T-35/-75/-150 (T)

TORX® Bits
TORX® Bits
Embout, TORX®

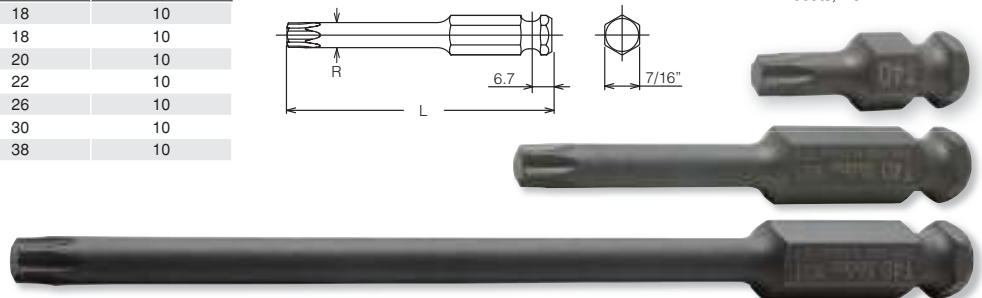
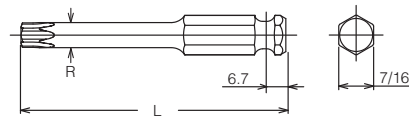

	183T-75 (T)	L (mm)	R (mm)	(g)	(pcs.)
	T30	75	6.0	35	10
	T40	75	6.9	37	10
	T45	75	8.0	41	10
	T50	75	9.0	45	10
	T55	75	11.4	55	10
	T60	75	13.5	67	10

	183T-150 (T)	L (mm)	R (mm)	(g)	(pcs.)
	T30	150	6.0	50	10
	T40	150	6.9	58	10
	T45	150	8.0	70	10
	T50	150	9.0	82	10
	T55	150	11.4	113	10

	183T-35 (IP)	L (mm)	(g)	(pcs.)
	30IP	35	18	10
	40IP	35	20	10
	45IP	35	22	10
	50IP	35	26	10
	55IP	35	30	10
	60IP	35	38	10

183T-35/-75 (IP)

TORXPLUS® Bits
TORXPLUS® Bits
Embout TORXPLUS®

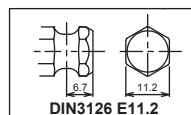
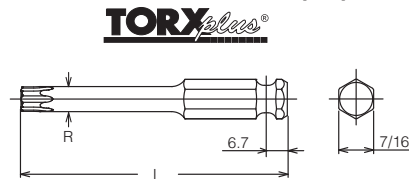

	183T-75 (IP)	L (mm)	R (mm)	(g)	(pcs.)
	30IP	75	6.0	35	10
	40IP	75	6.8	37	10
	45IP	75	8.0	41	10
	50IP	75	9.0	45	10
	55IP	75	11.4	56	10
	60IP	75	13.5	67	10



Z-SERIES
HAND
TITANIUM
ACCESSORIES
SCREWDRIVERS
IMPACT
SLEEVE-DRIVE
PROTECTOR
INDUSTRIAL
AUTOMOTIVE
MOTORCYCLE
CONSTRUCTION
SPARE PART

183X-35/-75/-150 (XZN)

XZN Bits
XZN Bits
Embouts, XZN

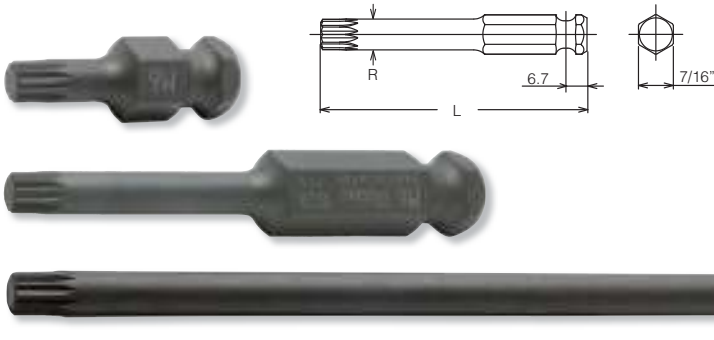

183X-35 (XZN)	L (mm)	(g)	(pcs.)
M 4	35	18	10
M 5	35	18	10
M 6	35	20	10
M 8	35	22	10
M10	35	26	10
M12	35	30	10
M14	35	38	10

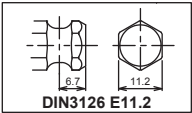

183X-75 (XZN)	L (mm)	R (mm)	(g)	(pcs.)
M 4	75	6.0	34	10
M 5	75	6.0	34	10
M 6	75	6.2	36	10
M 8	75	7.4	39	10
M10	75	9.8	54	10
M12	75	11.7	57	10
M14	75	13.5	67	10

183X-150 (XZN)	L (mm)	R (mm)	(g)	(pcs.)
M 5	150	6.0	50	10
M 6	150	6.2	53	10
M 8	150	7.4	64	10
M10	150	9.8	93	10
M12	150	11.7	121	10

13134 Impact Bit Holder 14134 Impact Klingenhalter 16134 Porte embouts Impact



	□	D (mm)	L (mm)	(g)	(pcs.)	⊖
13134	3/8"	22	32	70	10	*1
14134	1/2"	25	38	90	10	*2
16134	3/4"	44	52	200	2	*3

*1 C-Ring=1302C, Pin/O-Ring=1302A/B
*2 C-Ring=1401C, Pin/O-Ring=1401A/B → P250-251
*3 C-Ring=1600C, Pin/O-Ring=1601A/B

For DIN3126 E11.2 Bits
Für DIN3126 E11.2 Bits
Pour DIN3126 E11.2 Embouts

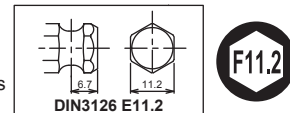

13134-SC

Replacement Screw : M8x5, ●4mm
Ersatzschraube : M8x5, ●4mm
Vis de remplacement : M8x5, ●4mm

13142-F11.2 Impact Bit Holder (Quick Release) 14142-F11.2 Impact Klingenhalter (Quick Release) Porte embouts Impact (Quick Release)

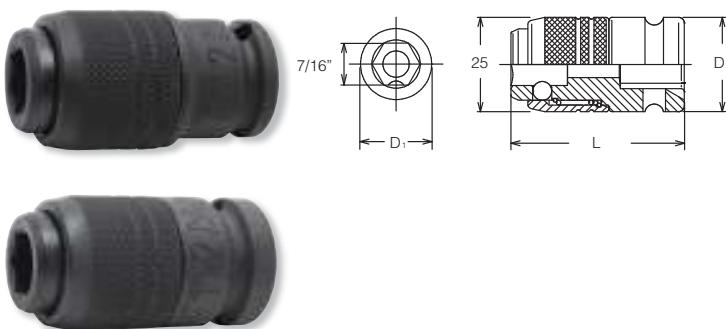

	□	D ₁ (mm)	D ₂ (mm)	L (mm)	(g)	(pcs.)	⊖
13142-F11.2	3/8"	18.9	22	46	116	10	*1
14142-F11.2	1/2"	18.9	25	46	207	10	*2

*1 C-Ring=1302C, Pin/O-Ring=1302A/B → P250-251
*2 C-Ring=1401C, Pin/O-Ring=1401A/B

For DIN3126 E11.2 Bits
Für DIN3126 E11.2 Bits
Pour DIN3126 E11.2 Embouts

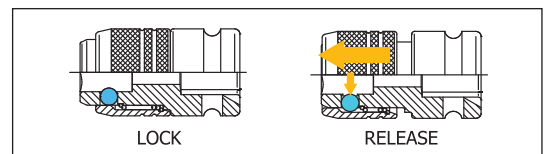
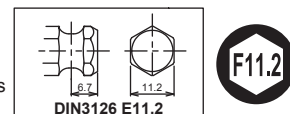

110		TYPE	L (mm)	(g)	(pcs.)
35B	1/4"	Ball	35	9	10
35P		Pin	35	9	10
50B		Ball	50	15	10
50P		Pin	50	15	10
100B		Ball	100	34	10
100P		Pin	100	34	10
150B	1/4"	Ball	150	54	10
150P		Pin	150	54	10

● DIN 3126 Form E 6.3

112		TYPE	L (mm)	(g)	(pcs.)
50B	3/8"	Ball	50	22	10
50P		Pin	50	22	10
100B		Ball	100	71	10
100P		Pin	100	71	10
150B		Ball	150	121	10
150P		Pin	150	121	10

● DIN 3126 Form E 6.3



135E		TYPE	L (mm)	(g)	(pcs.)
60B	1/2"	Ball	60	46	10
60P		Pin	60	46	10

● DIN 3126 Form E 6.3

117		TYPE	L (mm)	(g)	(pcs.)
50B	1/4"	Ball	50	15	10
50P		Pin	50	15	10
100B		Ball	100	71	10
100P		Pin	100	71	10

● DIN 3126 Form G7

120		TYPE	L (mm)	(g)	(pcs.)
50B	3/8"	Ball	50	27	10
50P		Pin	50	27	10

● DIN 3126 Form E 8

186		L (mm)	(g)	(pcs.)
75P	3/8"	75	65	10
75P	1/2"	75	85	10

● DIN 3126 Form E 11.2

110-35B/-50B/-100B/-150B -35P/-50P/-100P/-150P

Adaptors
Verbindungsstücke
Adaptateurs

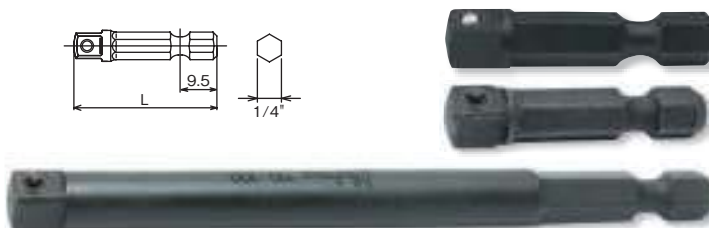

112-50B/-100B/-150B -50P/-100P/-150P

Adaptors
Verbindungsstücke
Adaptateurs

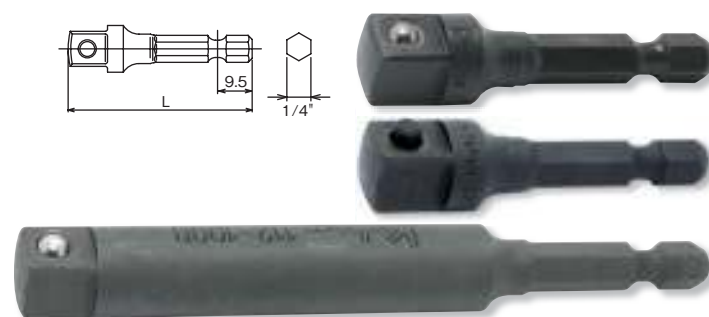

135E-60B/-60P

Adaptor
Verbindungsstück
Adaptateurs



117-50B/-100B -50P/-100P

Adaptors
Verbindungsstücke
Adaptateurs



120-50B/-50P

Adaptor
Verbindungsstück
Adaptateurs



186-75P

Adaptor
Verbindungsstück
Adaptateurs



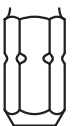

DIN 3126
Form C6.3

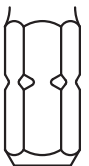

DIN 3126
Form C8

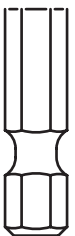

DIN 3126
Form E6.3



DIN 3126
Form G7



DIN 3126
Form E8

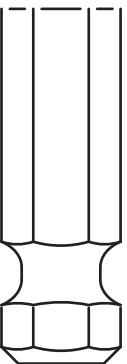

DIN 3126
Form E11.2

**SCREWDRIVERS
SCHRAUBENDREHER
TOURNEVIS**



Z-SERIES
HAND
TITANIUM
ACCESSORIES
SCREWDRIVERS
IMPACT
SLEEVE-DRIVE
PROTECTOR
INDUSTRIAL
AUTOMOTIVE
MOTORCYCLE
CONSTRUCTION
SPARE PART

167M / 167A

Socket Drivers
Sechskant Steckschlüssel, mit Griff
Clé à douille avec manche

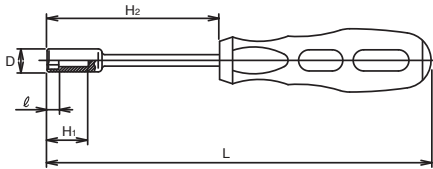

167M (mm)	D (mm)	ℓ (mm)	H ₁ (mm)	H ₂ (mm)	L (mm)	(g)	(pcs.)
3	5.8	3	25	125	225	62	6
3.5	5.8	3	25	125	225	62	6
4	6.7	3.5	25	125	225	64	6
4.5	7.2	4.5	25	125	225	65	6
5	7.8	5	25	125	225	66	6
5.5	8.4	5.5	25	125	225	68	6
6	9.1	6	25	125	225	70	6
7	10.9	6.5	25	125	235	101	6
8	12	7	25	125	235	103	6
9	13.2	7.5	25	125	235	107	6
10	14.5	8	25	125	235	111	6
11	15.9	8.5	25	125	245	155	6
12	16.8	9	25	125	245	161	6
13	18.2	9.5	25	125	245	167	6
14	19.2	11	25	125	245	178	6

167A (inch)	D (mm)	ℓ (mm)	H ₁ (mm)	H ₂ (mm)	L (mm)	(g)	(pcs.)
1/4	9.1	6	25	125	225	70	6

167C (2B)

Interchangeable Socket Driver, **Nut Grip**[®]
Universalgriff mit auswechselbaren **Nut Grip**[®] Steckschlüsselklingen
Clé à douille interchangeable avec manche **NUT Nut Grip**[®]

167C/3-2B

Set 3 pieces
Satz 3teilig
Jeu de 3 tournevis

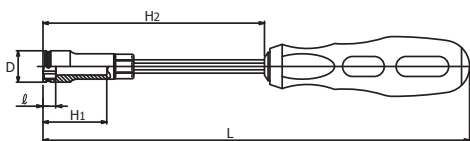

167C(2B) (mm)	D (mm)	ℓ (mm)	H ₁ (mm)	H ₂ (mm)	L (mm)	(g)	(pcs.)
7(2B)	11.5	4	38	122	235	120	6
8(2B)	12.3	5	38	122	235	125	6
10(2B)	14.2	6	38	122	235	130	6
12(2B)	17.3	7	38	122	235	135	6

167C/3-2B	4 Pieces Set/△=280g
PLASTIC BAG	
Socket Drivers	
Socket:	7, 8, 10
Grip:	167C-GRIP

168H-B



Ball Point Hex Screwdrivers
Schraubendreher Innensechskant mit Kugelkopf
Tournevis avec tête sphérique pour vis 6-pans creux

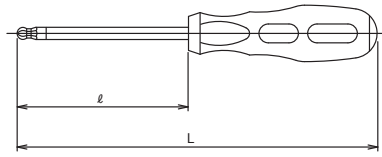

168H (mm)	ℓ (mm)	L (mm)	(g)	(pcs.)
3B	80	150	25	6
4B	125	225	60	6
5B	125	235	85	6
6B	125	245	150	6
7B	125	245	151	6
8B	125	245	153	6

Ball point Hex Screwdrivers have less strength due to the special design. Make sure to use them correctly.

168T (TH)



Screwdriver for TORX® Tamper Resistant
TORX® Schraubendreher Tamper-Resistant
Tournevis pour vis TORX® tamper resistant

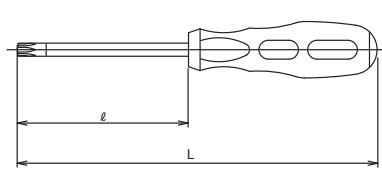

168T (TH)	ℓ (mm)	L (mm)	(g)	(pcs.)
T10H	80	150	25	6
T15H	80	150	25	6
T20H	125	225	60	6
T25H	125	225	60	6
T27H	125	235	90	6
T30H	125	235	92	6
T40H	125	245	153	6

Tamper Resistant TORX® Screwdrivers have less strength due to the special design. Make sure to use it correctly.

168T/7-TH	(g)
168T-T10H, T15H, T20H, T25H, T27H, T30H, T40H	480



168T/7 (TH)



Set 6 pieces
Satz 6teilig
Jeu de 6 tournevis



168R



Screwdriver for 4point screws
Schraubendreher für Innenvierkant-Schrauben
Tournevis pour vis à empreinte carrée

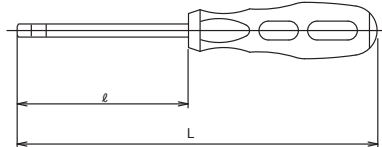

168R	ℓ (mm)	L (mm)	(g)	(pcs.)
1	125	225	60	6
2	125	235	85	6

168P (PZ)



Pozidriv Screwdrivers
Schraubendreher, Pozidriv
Tournevis pour vis Pozidriv

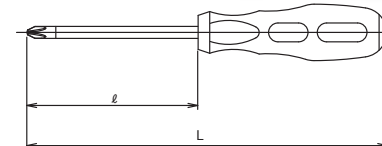

168P (PZ)	ℓ (mm)	L (mm)	(g)	(pcs.)
PZ1	75	175	78	6
PZ2	100	210	129	6
PZ3	150	270	203	6

Screwdrivers
Schraubendreher
Tournevis

Z-SERIES
HAND
TITANIUM
ACCESSORIES
SCREWDRIVERS
IMPACT
SLEEVE-DRIVE
PROTECTOR
INDUSTRIAL
AUTOMOTIVE
MOTORCYCLE
CONSTRUCTION
SPARE PART

166P  Screwdriver Phillips (Blade-Through type)
Kreuzschlitz Schraubendreher PH mit durchgehender 6-kant Klinge
Tournevis pour vis cruciformes Phillips

166S  Slotted screwdriver (Blade-Through type)
Schlitz-Schraubendreher mit durchgehender 6-kant Klinge
Tournevis pour vis à fente

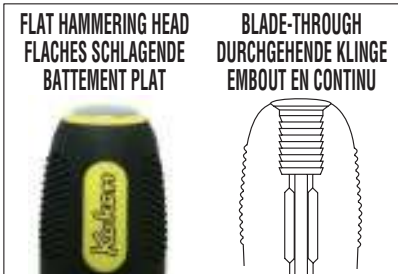
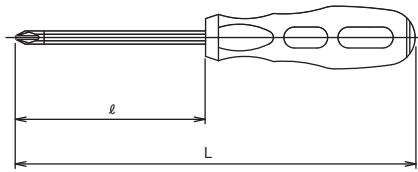



166P (PH)	ℓ (mm)	L (mm)	(g)	(pcs.)
1	75	175	78	6
2	100	210	129	6
3	150	270	203	6

166S	ℓ (mm)	L (mm)	(g)	(pcs.)
5	75	175	78	6
6	100	210	129	6
8	150	270	203	6



166PS/6   Set 6 pieces
Satz 6teilig
Jeu de 6 tournevis



166PS/6	6 Pieces Set/△=885g
CARDBOARD BOX:W280xH115xT40mm	
Screwdrivers	
	166P Screwdrivers 1, 2, 3
	166S Screwdrivers 5, 6, 8

PK166PS/6   Set 6 pieces in Plastic Box
Satz 6teilig in Plastikkassette
Module plastique des 6 tournevis



PK166PS/6	6 Pieces Set/△=950g
PLASTIC TRAY	
Screwdrivers	
	166P Screwdrivers 1, 2, 3
	166S Screwdrivers 5, 6, 8

Z-SERIES
HAND
TITANIUM
ACCESSORIES
SCREWDRIVERS
IMPACT
SLEEVE-DRIVE
PROTECTOR
INDUSTRIAL
AUTOMOTIVE
MOTORCYCLE
CONSTRUCTION
SPARE PART

- 168P** Screwdriver (Blade-Through Type), Phillips
Schraubendreher mit durchgehender Klinge, Phillips
Tournevis à zone de frappe, Phillips
- 168S** Slotted Screwdriver
Schlitz-Schraubendreher
Tournevis pour vis à fente

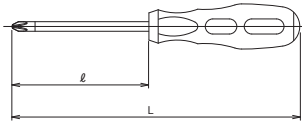

168P (PH)	ℓ (mm)	L (mm)	(g)	(pcs.)
1	75	175	59	6
2	100	210	86	6
2(150)	150	260	100	6
2(200)	200	310	111	6
2(300)	300	410	133	6
3	150	270	150	6

168S	ℓ (mm)	L (mm)	(g)	(pcs.)
5	75	175	59	6
6	100	210	86	6
6(150)	150	260	100	6
6(200)	200	310	111	6
6(300)	300	410	133	6
8	150	270	150	6

168PS/6 6 Pieces Set/△=660g
CARDBOARD BOX:W280xH115xT40mm

Screwdrivers
168P Screwdrivers
1, 2, 3
168S Screwdrivers
5, 6, 8

PK168PS/6 6 Pieces Set/△=720g

PLASTIC TRAY
Screwdrivers
168P Screwdrivers
1, 2, 3
168S Screwdrivers
5, 6, 8

- 168PS/6** Set 6 pieces
Satz 6teilig
Jeu de 6 tournevis



- PK168PS/6** Set 6 pieces in Plastic Box
Satz 6teilig in Plastikbox
Module plastique des 6 tournevis

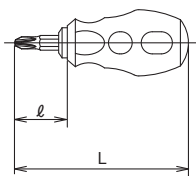

168CS	ℓ (mm)	L (mm)	(g)	(pcs.)
2x6	22	86	46	6

- 168CS** Interchangeable Screwdriver, Stubby
Schraubendrehergriff für auswechselbare Klinge, kurz
Poignée porte-lames reversible, court

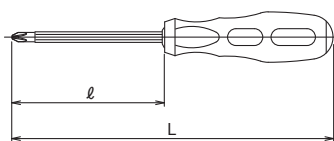

168C	ℓ (mm)	L (mm)	(g)	(pcs.)
2x6	100	210	108	6
2x6(150)	150	260	120	6
2x6(200)	200	310	133	6

- 168C** Interchangeable Screwdriver
Schraubendrehergriff für auswechselbare Klingen
Poignée porte-lames reversible



Screwdrivers
Schraubendreher
Tournevis

Z-SERIES
HAND
TITANIUM
ACCESSORIES
SCREWDRIVERS
IMPACT
SLEEVE-DRIVE
PROTECTOR
INDUSTRIAL
AUTOMOTIVE
MOTORCYCLE
CONSTRUCTION
SPARE PART

2769N-150/-220 Spin Type Handle
Drehgriff
Poignée emmanchée

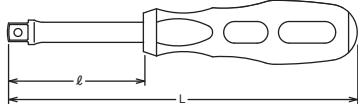

2769N		ℓ (mm)	L (mm)	(g)	(pcs.)
150	1/4"	50	150	68	2
220		120	220	100	2



Plastic or rubber handles are not intended to act as insulation.

Plastik-oder Gummigriffe stellen keinen Isolierschutz dar.

Les poignées en plastique ou en caoutchouc ne garantissent aucune isolation électrique.

2769NWF-150/-220 Spin Type Handle (Wobble-Fix)
Drehgriff, Wobble-Fix
Poignée emmanchée, angulaire

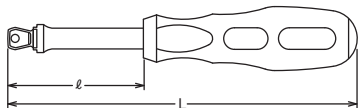

2769NWF		ℓ (mm)	L (mm)	(g)	(pcs.)
150	1/4"	50	150	68	2
220		120	220	100	2

Wobble-Fix Extension Bar

Two way usage

- a) In a fixed position, as a normal extension bar
- b) In a half-fixed position, as a flexible extension bar providing a 15° angle operation

Winkel-Verlängerungen

- Winkelverlängerungen lassen sich in zwei Einstellungen verwenden
- a) voll eingesteckt und starr,
- b) halb eingesteckt, mit einem Arbeitswinkel von 15°.

Rallonges angulaires

Deux utilisations possibles

- a) comme rallonge normale, dans une position fixe
- b) comme une rallonge angulaire avec une possibilité d'inclinaison jusqu'à 15°

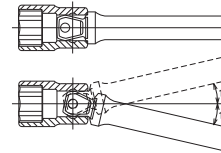

3769N-160/-230 Spin Type Handle
Drehgriff
Poignée emmanchée

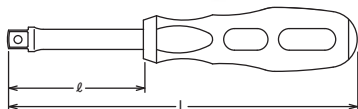

3769N		ℓ (mm)	L (mm)	(g)	(pcs.)
160	3/8"	50	160	96	2
230		120	230	126	2

3769NWF-160/-230 Spin Type Handle (Wobble-Fix)
Drehgriff, Wobble-Fix
Poignée emmanchée, angulaire

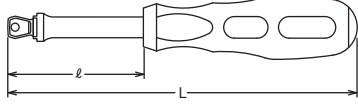

3769NWF		ℓ (mm)	L (mm)	(g)	(pcs.)
160	3/8"	50	160	96	2
230		120	230	126	2

IMPACT

SOCKETS
STECKSCHLÜSSEL
DOUILLES

1/4"

3/8"

1/2"

5/8"

3/4"

1"

1-1/2"

2-1/2"

3-1/2"



Impact Sockets Impact Steckschlüssel Douilles Impact

1/4"

Z-SERIES
HAND
TITANIUM
SCREWDRIVERS ACCESSORIES
IMPACT
SLEEVE-DRIVE
PROTECTOR
INDUSTRIAL
AUTOMOTIVE
MOTORCYCLE
CONSTRUCTION
SPARE PART

12400M / 12400A

6-point Sockets
6-kant Steckschlüssel
Douilles 6-pans

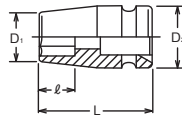

12400A (inch)	D ₁ (mm)	D ₂ (mm)	ℓ (mm)	L (mm)	(g)	(pcs.)	
5/32	7.5	13	4	23	14	10	*1
3/16	8.1	13	4	23	14	10	*1
7/32	9.4	13	4	23	16	10	*1
1/4	10	13	5	23	14	10	*1
9/32	11.3	13	5	23	14	10	*1
5/16	12.5	13	6	23	14	10	*1
11/32	13.8	13	7	23	14	10	*1
3/8	15	13	7	23	15	10	*1
7/16	16.3	13	8	23	18	10	*1
1/2	18.8	13	8	23	19	10	*1
9/16	20	13	9	23	20	10	*1

*1 Pin/O-Ring=1200A/B → P251

12400M (mm)	D ₁ (mm)	D ₂ (mm)	ℓ (mm)	L (mm)	(g)	(pcs.)	
4	7.5	13	4	23	14	10	*1
4.5	8.1	13	4	23	14	10	*1
5	8.8	13	4	23	14	10	*1
5.5	9.4	13	4	23	14	10	*1
6	10	13	5	23	14	10	*1
7	11.3	13	5	23	14	10	*1
8	12.5	13	6	23	14	10	*1
9	13.8	13	7	23	14	10	*1
10	15	13	7	23	15	10	*1
11	16.3	13	8	23	18	10	*1
12	17.5	13	8	23	19	10	*1
13	18.8	13	8	23	19	10	*1
14	20	13	9	23	20	10	*1

12400MG / 12400AG

6-point Sockets with Magnet
6-kant Steckschlüssel mit Magnet
Douilles 6-pans avec aimant

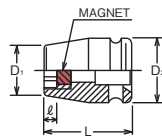

12400AG (inch)	D ₁ (mm)	D ₂ (mm)	ℓ (mm)	L (mm)	(g)	(pcs.)	
3/16	8.1	13	2.1	23	13	10	*1
1/4	10	13	2.4	23	16	10	*1
5/16	12.5	13	3.5	23	17	10	*1
11/32	13.8	13	3.8	23	18	10	*1
3/8	15	13	4.2	23	18	10	*1
7/16	16.3	13	4.9	23	21	10	*1
1/2	18.8	13	6	25	21	10	*1
9/16	20	13	6.4	25	20	10	*1

*1 Pin/O-Ring=1200A/B → P251

12400MG (mm)	D ₁ (mm)	D ₂ (mm)	ℓ (mm)	L (mm)	(g)	(pcs.)	
4	7.5	13	2.1	23	12	10	*1
4.5	8.1	13	2.1	23	13	10	*1
5	8.8	13	2.1	23	15	10	*1
5.5	9.4	13	2.1	23	15	10	*1
6	10	13	2.4	23	16	10	*1
7	11.3	13	2.8	23	16	10	*1
8	12.5	13	3.5	23	17	10	*1
9	13.8	13	3.8	23	18	10	*1
10	15	13	4.2	23	18	10	*1
11	16.3	13	4.9	23	21	10	*1
12	17.5	13	5.6	25	21	10	*1
13	18.8	13	6	25	21	10	*1
14	20	13	6.4	25	20	10	*1

12410M

Surface Drive Sockets
Surface Drive Steckschlüssel
Douilles, Surface Drive

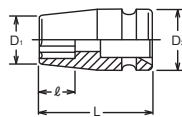

12410M (mm)	D ₁ (mm)	D ₂ (mm)	ℓ (mm)	L (mm)	(g)	(pcs.)	
6	10	13	5	23	14	10	*1
7	11.3	13	5	23	15	10	*1
8	12.5	13	6	23	15	10	*1
9	13.8	13	7	23	14	10	*1
10	15	13	7	23	14	10	*1
11	16.3	13	8	23	17	10	*1
12	17.5	13	8	23	19	10	*1
13	18.8	13	8	23	19	10	*1

*1 Pin/O-Ring=1200A/B → P251

SURFACE DRIVE

Surface drive sockets are designed to retain contact with the flat sides of the nut in order to transmit higher torque and reduce nut wear. These sockets are ideal for using on polished nuts, aluminum nuts and nuts with worn out points.

Das Profil unserer Surface-Drive Steckschlüssel greift die Schraube an deren Flächen. Dies sichert eine höhere Kraftübertragung und verhindert ein Durchrutschen des Steckschlüssels. Diese Steckschlüssel eignen sich besonders für polierte Schrauben, Aluminium Schrauben und Schrauben bei denen die Ecken bereits abgerundet sind.

Notre profil Surface Drive assure le contact entre la douille et les plats de l'écrou. Ceci réduit l'usure et permet la transmission d'un couple plus élevé. C'est une solution idéale pour les écrous polies, celles en aluminium ou arrondies.



12465M (mm)	D ₁ (mm)	D ₂ (mm)	ℓ (mm)	L (mm)	(g)	(pcs.)	⚡
10	15	13	8	23	17	10	*1
11	16.3	13	8	23	18	10	*1
12	17.5	13	9	23	18	10	*1
13	18.8	13	9	23	20	10	*1

*1 Pin/O-Ring=1200A/B → P251



12465M Pathfinder Sockets Pathfinder Steckschlüssel Douilles Pathfinder

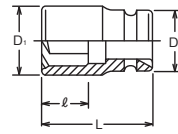

PATHFINDER®

The beveled flats of the 6-points opening of the PATHFINDER socket engage the nut almost immediately. PATHFINDER sockets are ideal for using with power tools in automatic assembly processes, as the power tool does not have to be totally stopped for the socket to engage the nut.

Da die Maschine nicht nach jedem Schraubvorgang angehalten werden muss, ergibt sich eine erhöhte Produktivität, die sich bei vollautomatischen Maschinen (Mehrspendelschrauber) ganz besonders auswirkt.

Les parois en biais des douilles en 6-pans Pathfinder assurent l'engagement quasi immédiat de l'écrou. Le fait de ne pas devoir arrêter la machine après chaque serrage, engendre une productivité supérieure dans les chaînes de montage automatiques.

12425 (E)	D ₁ (mm)	D ₂ (mm)	ℓ (mm)	L (mm)	(g)	(pcs.)	⚡
E 4	6.6	13	4.6	23	14	10	*1
E 5	7.7	13	5.2	23	15	10	*1
E 6	8.7	13	5.4	23	15	10	*1
E 7	9.2	13	6.6	23	15	10	*1
E 8	9.7	13	7	23	15	10	*1
E10	12.2	13	8.2	23	15	10	*1

*1 Pin/O-Ring=1200A/B → P251

12425 TORX® Sockets TORX® Steckschlüssel Douilles TORX®

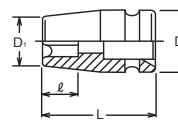

TORX® (E)

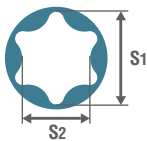

E		E4	E5	E6	E7	E8	E10	E11	E12	E14	E16	E18	E20	E22	E24	E26	E28
S ₁	(ref. mm)	3.7	4.6	5.6	6.1	7.4	9.3	9.9	11.0	12.8	14.6	16.5	18.3	20.1	22.0	23.7	25.5
S ₂	(ref. mm)	2.7	3.3	4.0	4.3	5.3	6.8	7.1	7.9	9.2	10.5	11.9	13.2	14.8	15.7	17.5	18.3

12460M (mm)	D ₁ (mm)	D ₂ (mm)	ℓ (mm)	L (mm)	(g)	(pcs.)	⚡
5.5	9.7	13	4	23	15	10	*1
6	10.3	13	5	23	15	10	*1
7	11.6	13	5	23	16	10	*1
8	12.8	13	6	23	16	10	*1
10	15.3	13	7	23	19	10	*1
13	19.1	13	8	23	23	10	*1

12460A (inch)	D ₁ (mm)	D ₂ (mm)	ℓ (mm)	L (mm)	(g)	(pcs.)	⚡
1/4	10.3	13	5	23	15	10	*1
5/16	12.8	13	6	23	16	10	*1
3/8	15.3	13	7	23	19	10	*1
1/2	19.1	13	8	23	23	10	*1

*1 Pin/O-Ring=1200A/B → P251

12460M For Self-Tapping Screws Für selbstschneidende Schrauben Pour vis auto-taraudeuses

12460A

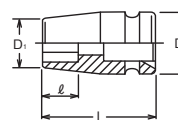

12460MG (mm)	D ₁ (mm)	D ₂ (mm)	ℓ (mm)	L (mm)	(g)	(pcs.)	⚡
5.5	9.7	13	2.1	23	16	10	*1
6	10.3	13	2.4	23	16	10	*1
7	11.6	13	2.8	23	16	10	*1
8	12.8	13	3.5	25	18	10	*1
10	15.3	13	4.2	28	20	10	*1
12	17.9	13	8	30	41	10	*1
13	19.1	13	6	30	23	10	*1
14	20	13	6.4	30	24	10	*1

New

12460AG (inch)	D ₁ (mm)	D ₂ (mm)	ℓ (mm)	L (mm)	(g)	(pcs.)	⚡
1/4	10.3	13	2.4	23	16	10	*1
5/16	12.8	13	3.5	25	18	10	*1
3/8	15.3	13	4.2	28	20	10	*1
7/16	16.6	13	4.9	29	27	10	*1
1/2	19.1	13	6	30	23	10	*1

*1 Pin/O-Ring=1200A/B → P251

12460MG With Magnet for Self-Tapping Screws mit Magnet für selbstschneidende Schrauben avec aimant pour vis auto-taraudeuses

12460AG

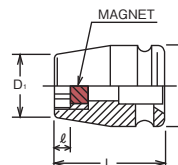

Impact Sockets Impact Steckschlüssel Douilles Impact

1/4"

Z-SERIES
HAND
TITANIUM
ACCESSORIES
SCREWDRIVERS
IMPACT
SLEEVE-DRIVE
PROTECTOR
INDUSTRIAL
AUTOMOTIVE
MOTORCYCLE
CONSTRUCTION
SPARE PART

12300M

6-point Sockets, deep
6-kant Steckschlüssel, lang
Douilles longues, 6-pans



12300M (mm)	D ₁ (mm)	D ₂ (mm)	l (mm)	H (mm)	L (mm)	(g)	(pcs.)	
6	10	13	6	38	48	26	10	*1
7	11.3	13	7	38	48	30	10	*1
8	12.5	13	8	38	48	32	10	*1
10	15	13	10	37	48	34	10	*1
11	16.3	13	11	37	48	46	10	*1
12	17.5	13	12	37	48	49	10	*1
13	18.8	13	13	37	48	52	10	*1
14	20	13	14	36	48	57	10	*1

*1 Pin/O-Ring=1200A/B → P251

12365M

Pathfinder Sockets, deep
Pathfinder Steckschlüssel, lang
Douilles longues, Pathfinder



12365M (mm)	D ₁ (mm)	D ₂ (mm)	l (mm)	H (mm)	L (mm)	(g)	(pcs.)	
10	15	13	8	37	48	34	10	*1
11	16.3	13	8	37	48	46	10	*1
12	17.5	13	9	37	48	49	10	*1
13	18.8	13	9	37	48	52	10	*1

*1 Pin/O-Ring=1200A/B → P251

12300G

Impact Socket with Sliding Magnet
Impact Steckschlüssel mit versenkbarem Magnet
Douilles Impact avec aimant, glissant pour écrous

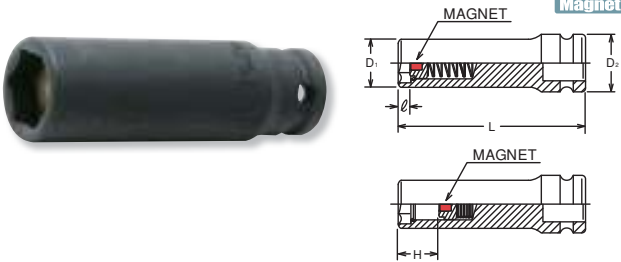

12300G (mm)	D ₁ (mm)	D ₂ (mm)	l (mm)	H (mm)	L (mm)	(g)	(pcs.)	
8	12.5	13	4	22	48	32	10	*1
10	15	13	4.5	20.5	48	34	10	*1
12	17.5	13	6	24.5	48	49	10	*1
13	18.8	13	6.5	23	48	52	10	*1
14	20	13	7	21	48	57	10	*1

*1 Pin/O-Ring=1200A/B → P251



12139

Impact Bit Holder
Impact Klingenhalter
Porte embouts Impact



	D ₁ (mm)	D ₂ (mm)	L (mm)	(g)	(pcs.)	
12139-1/4	11	13	25	15	10	*1

*1 Pin/O-Ring=1200A/B → P251

For DIN3126 C6.3 Bits
Für DIN3126 C6.3 Bits
Pour DIN3126 C6.3 Embouts

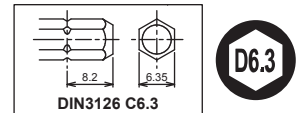

12140

Impact Bit Holder
Impact Klingenhalter
Porte embouts Impact



	D ₁ (mm)	D ₂ (mm)	L (mm)	(g)	(pcs.)	
12140-5/16	14	13	25	15	10	*1

*1 Pin/O-Ring=1200A/B → P251

For DIN3126 C8 Bits
Für DIN3126 C8 Bits
Pour DIN3126 C8 Embouts

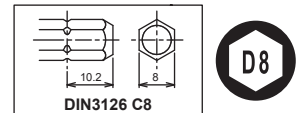

12142-F6.3

Impact Bit Holder
Impact Klingenhalter
Porte embouts Impact



	D ₁ (mm)	D ₂ (mm)	L (mm)	(g)	(pcs.)	
12142-F6.3	16.5	13	36	22	10	*1

*1 Pin/O-Ring=1200A/B → P251

For DIN3126 E6.3 Bits
Für DIN3126 E6.3 Bits
Pour DIN3126 E6.3 Embouts

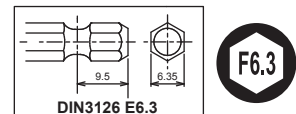

Lock & Quick Release

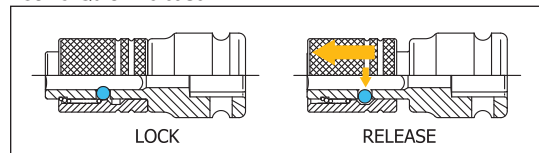

	TYPE	D (mm)	L (mm)	(g)	(pcs.)	⚡
12760-55P	Pin	13	55	26	10	*1
New 12760-55	Hole	13	55	26	10	*1
12760-75P	Pin	13	75	45	10	*1
New 12760-75	Hole	13	75	45	10	*1
12760-100P	Pin	13	100	50	10	*1
New 12760-100	Hole	13	100	50	10	*1
New 12760-150P	Pin	13	150	60	10	*1
New 12760-150	Hole	13	150	60	10	*1
New 12760-200P	Pin	13	200	80	10	*1

*1 Pin/O-Ring=1200A/B → P251

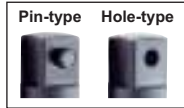

	L (mm)	(g)	(pcs.)	⚡
12222AL	35	30	10	*1

*1 Pin/O-Ring=1200A/B → P251

Lock & Quick Release

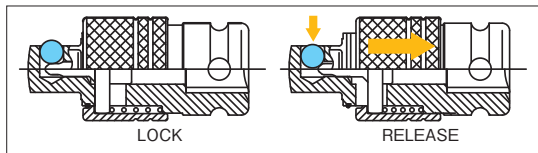

	TYPE	L (mm)	(g)	(pcs.)	⚡
12770-P	Pin	39	30	10	*1
New 12770	Hole	39	30	10	*1

*1 Pin/O-Ring=1200A/B → P251

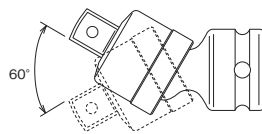

	TYPE	(sq.)	(sq.)	L (mm)	(g)	(pcs.)	⚡
12233A-P	Pin	1/4"	3/8"	22	15	10	*1
New 12233A	Hole	1/4"	3/8"	22	15	10	*1

*1 Pin/O-Ring=1200A/B → P251

12760-P 12760

Extension Bars
Verlängerungen
Rallonges

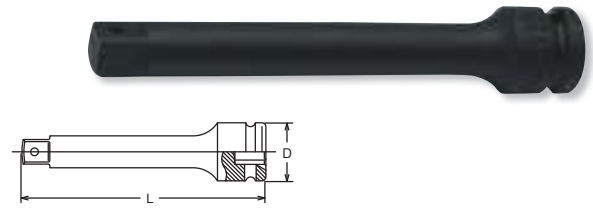

12222AL

Adaptor (Quick Release)
Schnellwechsel-Verbindungsstück
Adaptateur autoserrant



12770-P 12770

Universal Joint
Gelenk-Einsatz
Joint articlé



12233A-P 12233A

Adaptor
Verbindungsstück
Augmentateur





3/8"

Impact Sockets Impact Steckschlüssel Douilles Impact

13401M (mm)	D ₁ (mm)	D ₂ (mm)	ℓ (mm)	L (mm)	(g)	(pcs.)	⚡
6	9.8	18.5	5	32	28	10	*1
7	11	18.5	5	32	30	10	*1
8	12.3	18.5	6	32	31	10	*1
9	13.5	18.5	7	32	32	10	*1
10	14.8	18.5	7	32	34	10	*1
11	16	18.5	8	32	35	10	*1
12	17.3	18.5	9	32	36	10	*1
13	18.5	21.5	10	32	43	10	*2
14	19.8	21.5	10	32	49	10	*2
15	21	21.5	11	32	49	10	*2
16	22.3	21.5	11	32	51	10	*2
17	23.5	21.5	12	32	54	10	*2
18	24.8	21.5	12	32	57	10	*2
19	26	21.5	12	32	60	10	*2
20	27.3	21.5	12	32	65	10	*2
21	28.5	21.5	12	32	70	10	*2
22	29.8	21.5	13	32	73	10	*2
23	31	21.5	13	32	73	10	*2
24	32.3	21.5	13	32	75	10	*2

*1 C-Ring=1301C, Pin/O-Ring=1301A/B
*2 C-Ring=1302C, Pin/O-Ring=1302A/B

→ P250-251

13401M  6-point Socket, Thin Walled
13401A  6-kant Steckschlüssel, dünnwandig
Douilles à paroi mince, 6-pans

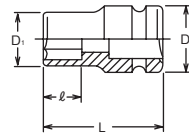

13401A (inch)	D ₁ (mm)	D ₂ (mm)	ℓ (mm)	L (mm)	(g)	(pcs.)	⚡
1/4	9.8	18.5	5	32	28	10	*1
5/16	12.3	18.5	6	32	31	10	*1
3/8	14.8	18.5	7	32	34	10	*1
7/16	16	18.5	8	32	35	10	*1
1/2	18.5	21.5	10	32	43	10	*2
9/16	19.8	21.5	10	32	49	10	*2
5/8	22.3	21.5	11	32	51	10	*2
11/16	23.5	21.5	12	32	54	10	*2
3/4	26	21.5	12	32	60	10	*2
13/16	28.5	21.5	12	32	70	10	*2
7/8	29.8	21.5	13	32	73	10	*2

*1 C-Ring=1301C, Pin/O-Ring=1301A/B
*2 C-Ring=1302C, Pin/O-Ring=1302A/B

→ P250-251

RS13401M/9	9 Pieces Set/Rail 250mm	(g)
8, 10, 12, 13, 14, 17, 19, 21, 22		505

RS13401M/9  Socket Set on Rail
Steckschlüsselsatz auf Schiene
Jeu de douilles sur rail



13406M (mm)	D ₁ (mm)	D ₂ (mm)	ℓ (mm)	L (mm)	(g)	(pcs.)	⚡
6	9.8	18.5	5	32	28	10	*1
7	11	18.5	5	32	30	10	*1
8	12.3	18.5	6	32	31	10	*1
9	13.5	18.5	7	32	32	10	*1
10	14.8	18.5	7	32	34	10	*1
11	16	18.5	8	32	35	10	*1
12	17.3	18.5	9	32	36	10	*1
13	18.5	21.5	10	32	43	10	*2
14	19.8	21.5	10	32	49	10	*2
15	21	21.5	11	32	49	10	*2
16	22.3	21.5	11	32	51	10	*2
17	23.5	21.5	12	32	54	10	*2
18	24.8	21.5	12	32	57	10	*2
19	26	21.5	12	32	60	10	*2
20	27.3	21.5	12	32	65	10	*2
21	28.5	21.5	12	32	70	10	*2
22	29.8	21.5	13	32	73	10	*2
23	31	21.5	13	32	73	10	*2
24	32.3	21.5	13	32	75	10	*2

*1 C-Ring=1301C, Pin/O-Ring=1301A/B
*2 C-Ring=1302C, Pin/O-Ring=1302A/B

→ P250-251

13406M  12-point Socket, Thin Walled
13406A  12-kant Steckschlüssel, dünnwandig
Douilles à paroi mince, 12-pans

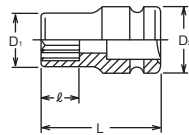

13406A (inch)	D ₁ (mm)	D ₂ (mm)	ℓ (mm)	L (mm)	(g)	(pcs.)	⚡
1/4	9.8	18.5	5	32	28	10	*1
5/16	12.3	18.5	6	32	31	10	*1
3/8	14.8	18.5	7	32	34	10	*1
7/16	16	18.5	8	32	35	10	*1
1/2	18.5	21.5	10	32	43	10	*2
9/16	19.8	21.5	10	32	49	10	*2
5/8	22.3	21.5	11	32	51	10	*2
11/16	23.5	21.5	12	32	54	10	*2
3/4	26	21.5	12	32	60	10	*2
13/16	28.5	21.5	12	32	70	10	*2
7/8	29.8	21.5	13	32	73	10	*2

*1 C-Ring=1301C, Pin/O-Ring=1301A/B
*2 C-Ring=1302C, Pin/O-Ring=1302A/B

→ P250-251

Z-SERIES
HAND
TITANIUM
ACCESSORIES
SCREWDRIVERS
IMPACT
SLEEVE-DRIVE
PROTECTOR
INDUSTRIAL
AUTOMOTIVE
MOTORCYCLE
CONSTRUCTION
SPARE PART

13400MG / 13400AG

6-point Sockets with Magnet
6-kant Steckschlüssel mit Magnet
Douilles 6-pans avec aimant

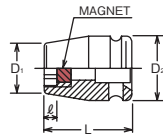

13400AG (inch)	D ₁ (mm)	D ₂ (mm)	ℓ (mm)	L (mm)	(g)	(pcs.)	
1/4	10.8	19	2.4	32	46	10	*1
5/16	13.3	19	3.5	32	45	10	*1
11/32	14.5	19	3.8	32	44	10	*1
3/8	15.8	19	4.2	32	49	10	*1
7/16	17	19	4.9	32	50	10	*1
1/2	19.5	22	6	32	70	10	*2
9/16	20.8	22	6.4	32	76	10	*2
5/8	23.3	22	7	32	88	10	*2
11/16	24.5	22	7.5	32	95	10	*2
3/4	27	22	8	32	116	10	*2

*1 C-Ring=1301C, Pin/O-Ring=1301A/B
*2 C-Ring=1302C, Pin/O-Ring=1302A/B

→ P250-251

13400MG (mm)	D ₁ (mm)	D ₂ (mm)	ℓ (mm)	L (mm)	(g)	(pcs.)	
6	10.8	19	2.4	32	46	10	*1
7	12	19	2.8	32	45	10	*1
8	13.3	19	3.5	32	45	10	*1
9	14.5	19	3.8	32	44	10	*1
10	15.8	19	4.2	32	49	10	*1
11	17	19	4.9	32	50	10	*1
12	18.3	19	5.6	32	55	10	*1
13	19.5	22	6	32	70	10	*2
14	20.8	22	6.4	32	76	10	*2
15	22	22	6.8	32	76	10	*2
16	23.3	22	7	32	88	10	*2
17	24.5	22	7.5	32	95	10	*2
18	25.8	22	7.8	32	105	10	*2
19	27	22	8	32	116	10	*2
21	29.5	22	8	32	125	10	*2
22	30.8	22	9.5	32	135	10	*2

*1 C-Ring=1301C, Pin/O-Ring=1301A/B → P250-251
*2 C-Ring=1302C, Pin/O-Ring=1302A/B

13410M

Surface Drive Sockets
Surface Drive Steckschlüssel
Douilles, Surface Drive

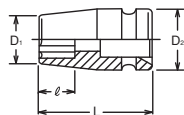

13410M (mm)	D ₁ (mm)	D ₂ (mm)	ℓ (mm)	L (mm)	(g)	(pcs.)	
6	10.8	19	5	32	40	10	*1
7	12	19	5	32	40	10	*1
8	13.3	19	6	32	40	10	*1
9	14.5	19	7	32	40	10	*1
10	15.8	19	7	32	40	10	*1
11	17	19	8	32	42	10	*1
12	18.3	19	9	32	50	10	*1
13	19.5	22	10	32	56	10	*2
14	20.8	22	10	32	56	10	*2
15	22	22	11	32	56	10	*2
16	23.3	22	11	32	57	10	*2
17	24.5	22	12	32	60	10	*2
18	25.8	22	12	32	62	10	*2
19	27	22	12	32	67	10	*2
22	30.8	22	13	32	72	10	*2

*1 C-Ring=1301C, Pin/O-Ring=1301A/B → P250-251
*2 C-Ring=1302C, Pin/O-Ring=1302A/B

13465M

Pathfinder Sockets
Pathfinder Steckschlüssel
Douilles Pathfinder

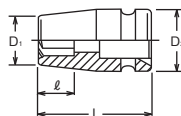

PATHFINDER®

The beveled flats of the 6-points opening of the PATHFINDER socket engage the nut almost immediately. PATHFINDER sockets are ideal for using with power tools in automatic assembly processes, as the power tool does not have to be totally stopped for the socket to engage the nut.

Da die Maschine nicht nach jedem Schraubvorgang angehalten werden muss, ergibt sich eine erhöhte Produktivität, die sich bei vollautomatischen Maschinen (Mehrschraubmaschinen) ganz besonders auswirkt.

Les parois en biais des douilles en 6-pans Pathfinder assurent l'engagement quasi immédiat de l'écrou. Le fait de ne pas devoir arrêter la machine après chaque serrage, engendre une productivité supérieure dans les chaînes de montage automatiques.

13425

TORX® Sockets
TORX® Steckschlüssel
Douilles TORX®

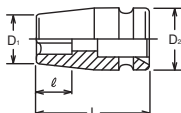

13425 (E)	D ₁ (mm)	D ₂ (mm)	ℓ (mm)	L (mm)	(g)	(pcs.)	
E 4	9.7	19	4.6	32	44	10	*1
E 5	10.2	19	5.2	32	43	10	*1
E 6	10.7	19	5.4	32	44	10	*1
E 7	11.2	19	6.6	32	44	10	*1
E 8	11.7	19	7	32	44	10	*1
E10	12.2	19	8.2	32	42	10	*1
E12	14.2	19	9.3	32	43	10	*1
E14	17.2	19	10.6	32	44	10	*1
E16	18.2	19	11.8	32	42	10	*1

*1 C-Ring=1301C, Pin/O-Ring=1301A/B → P250-251



3/8"

Impact Sockets Impact Steckschlüssel Douilles Impact

Z-SERIES
HAND
TITANIUM
ACCESSORIES
SCREWDRIVERS
IMPACT
SLEEVE-DRIVE
PROTECTOR
INDUSTRIAL
AUTOMOTIVE
MOTORCYCLE
CONSTRUCTION
SPARE PART

13425 (EPL)	D ₁ (mm)	D ₂ (mm)	ℓ (mm)	L (mm)	(g)	(pcs.)	⚡
8EPL	12	19	5.2	32	44	10	*1
10EPL	13.3	19	6.2	32	44	10	*1
12EPL	15.8	19	7.2	32	44	10	*1
14EPL	18.3	19	8.1	32	46	10	*1
16EPL	19.5	19	9.2	32	41	10	*1

*1 C-Ring=1301C, Pin/O-Ring=1301A/B → P250-251

13460M (mm)	D ₁ (mm)	D ₂ (mm)	ℓ (mm)	L (mm)	(g)	(pcs.)	⚡
6	11.4	19	5	32	43	10	*1
7	12.8	19	5	32	44	10	*1
8	14.1	19	6	32	44	10	*1
10	16.6	19	7	32	45	10	*1
12	19	19.2	9	32	48	10	*2
13	20.3	22	10	32	60	10	*2

13460A (inch)	D ₁ (mm)	D ₂ (mm)	ℓ (mm)	L (mm)	(g)	(pcs.)	⚡
1/4	11.4	19	5	32	43	10	*1
3/8	16.6	19	7	32	45	10	*1
1/2	20.3	22	10	32	60	10	*2

*1 C-Ring=1301C, Pin/O-Ring=1301A/B
*2 C-Ring=1302C, Pin/O-Ring=1302A/B → P250-251

13460MG (mm)	D ₁ (mm)	D ₂ (mm)	ℓ (mm)	L (mm)	(g)	(pcs.)	⚡
6	11.4	19	2.4	32	44	10	*1
7	12.8	19	2.8	32	46	10	*1
8	14.1	19	3.5	32	48	10	*1
10	16.6	19	4.2	33	54	10	*1
13	20.3	22	6	34	81	10	*2

13460AG (inch)	D ₁ (mm)	D ₂ (mm)	ℓ (mm)	L (mm)	(g)	(pcs.)	⚡
1/4	11.4	19	2.4	32	44	10	*1
5/16	14.1	19	3.5	32	48	10	*1
3/8	16.6	19	4.2	33	54	10	*1
1/2	20.3	22	6	34	81	10	*2

*1 C-Ring=1301C, Pin/O-Ring=1301A/B
*2 C-Ring=1302C, Pin/O-Ring=1302A/B → P250-251

13401LH (LH-S)	D ₁ (mm)	D ₂ (mm)	ℓ (mm)	L (mm)	(g)	(pcs.)	⚡
5S	11	19	5	32	32	10	*1
6S	12.3	19	5.6	32	34	10	*1
8S	16	19	6.8	32	36	10	*1
10S	18.5	22	8	32	50	10	*2
12S	22.3	22	9.2	32	58	10	*2
14S	24.8	22	10.4	32	63	10	*2
16S	28.5	22	11.6	32	77	10	*2

*1 C-Ring=1301C, Pin/O-Ring=1301A/B
*2 C-Ring=1302C, Pin/O-Ring=1302A/B → P250-251

LHSTIX®

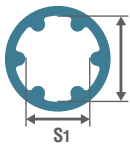

LH-S		LH-5S	LH-6S	LH-8S	LH-10S	LH-12S	LH-14S	LH-16S
S ₁	(ref. mm)	5.6	6.8	9.0	11.3	13.6	15.8	18.1
S ₂	(ref. mm)	7.5	9.0	12.0	15.0	18.0	21.0	24.0

13400-WN	D ₁ (mm)	D ₂ (mm)	ℓ (mm)	L (mm)	(g)	(pcs.)	⚡
6WN	15.8	19	6	32	48	10	*1
8WN	18.3	19	8	32	48	10	*1
9WN	19.5	22	9	32	47	10	*2
10WN	20.8	22	10	32	65	10	*2
12WN	24.5	22	12	32	73	10	*2
14WN	27	22	14	32	79	10	*2
17WN	32	22	17	35	110	10	*2

*1 C-Ring=1301C, Pin/O-Ring=1301A/B
*2 C-Ring=1302C, Pin/O-Ring=1302A/B → P250-251

13425-EPL

TORXPLUS® Sockets
TORXPLUS® Steckschlüssel
Douilles TORXPLUS®

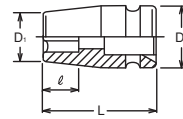

13460M / 13460A

For Self-Tapping Screws
Für selbstschneidende Schrauben
Pour vis auto-taraudeuses

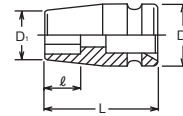

13460MG 13460AG

Sockets with magnets for Self-Tapping Screws
Steckschlüssel mit Magnet für selbstschneidende Schrauben
Douilles avec aimant pour vis auto-taraudeuses

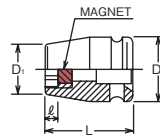

13401LH

LHS Sockets
Steckschlüssel mit LHS Profil
Douilles au profil LHS

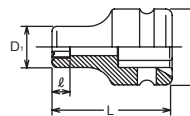

13400-WN

Weld Nut Sockets
Steckschlüssel für Schweissmuttern
Douilles pour écrou à souder

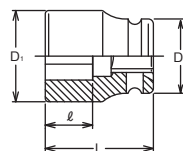

TORXPLUS is a registered trademark of Acument Intellectual Properties, LLC.
TORXPLUS ist ein registriertes Markenzeichen der Firma Acument Intellectual Properties, LLC.
TORXPLUS est une marque déposée de Acument Intellectual Properties, LLC.

LHSTIX is a registered trademark of OSG CORPORATION System Engineering Department.
LHSTIX ist ein registriertes Markenzeichen der Firma OSG CORPORATION System Engineering Department.
LHSTIX est une marque déposée de OSG CORPORATION System Engineering Department.

Impact Sockets

Impact Steckschlüssel

Douilles Impact

3/8"

Z-SERIES
HAND
TITANIUM
SCREWDRIVERS
ACCESSORIES
IMPACT
SLEEVE-DRIVE
PROTECTOR
INDUSTRIAL
AUTOMOTIVE
MOTORCYCLE
CONSTRUCTION
SPARE PART

13301X

6-point Semi-Deep Socket, Thin Walled
6-kant Steckschlüssel mittel lang, dünnwandig
Douilles à paroi mince semi-longues, 6-pans

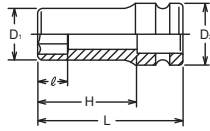

13301X (mm)	D ₁ (mm)	D ₂ (mm)	ℓ (mm)	H (mm)	L (mm)	(g)	(pcs.)	
7	11	18.5	7	36.5	50	40	10	*1
8	12.3	18.5	8	36.5	50	40	10	*1
10	14.8	18.5	10	36.5	50	46	10	*1
11	16	18.5	11	36.5	50	49	10	*1
12	17.3	18.5	12	36.5	50	53	10	*1
13	18.5	21.5	13	36.5	50	67	10	*2
14	19.8	21.5	14	36.5	50	70	10	*2
15	21	21.5	15	35.5	50	75	10	*2
16	22.3	21.5	16	35.5	50	78	10	*2
17	23.5	21.5	17	35.5	50	82	10	*2
18	24.8	21.5	18	34.5	50	86	10	*2
19	26	21.5	19	34.5	50	93	10	*2
21	28.5	21.5	21	34.5	50	104	10	*2
22	29.8	21.5	22	33.5	50	110	10	*2
23	31	21.5	23	33.5	50	115	10	*2
24	32.3	21.5	24	32.5	50	120	10	*2

*1 C-Ring=1301C, Pin/O-Ring=1301A/B
*2 C-Ring=1302C, Pin/O-Ring=1302A/B
→ P250-251

RS13301X/9

Socket Set on Rail
Steckschlüsselsatz auf Schiene
Jeu de douilles sur rail



RS13301X/9	9 Pieces Set/Rail 250mm	(g)
8, 10, 12, 13, 14, 17, 19, 21, 22		710

13300XG

Impact semi-deep socket with Sliding Magnet
Impact Steckschlüssel mittel lang mit versenkbarem Magnet
Douilles semi-longues avec aimant, glissant pour écrous

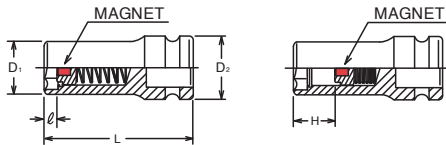

13300XG (mm)	D ₁ (mm)	D ₂ (mm)	ℓ (mm)	H (mm)	L (mm)	(g)	(pcs.)	
7	12	19	3.5	19	50	52	10	*1
8	13.3	19	4	20.5	50	40	10	*1
10	15.8	19	4.5	20	50	46	10	*1
11	17	19	5	20	50	50	10	*1
12	18.3	19	6	20	50	55	10	*1
13	19.5	22	6.5	19	50	70	10	*2
14	20.8	22	7	18	50	75	10	*2

*1 C-Ring=1301C, Pin/O-Ring=1301A/B
*2 C-Ring=1302C, Pin/O-Ring=1302A/B
→ P250-251

13300M / 13300A

6-point Sockets, deep
6-kant Steckschlüssel, lang
Douilles longues, 6-pans

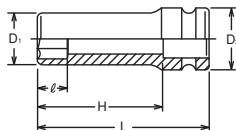

13300M (mm)	D ₁ (mm)	D ₂ (mm)	ℓ (mm)	H (mm)	L (mm)	(g)	(pcs.)	
6	10.8	19	6	66.5	80	77	10	*1
7	12	19	7	66.5	80	82	10	*1
8	13.3	19	8	66.5	80	82	10	*1
9	14.5	19	9	66.5	80	88	10	*1
10	15.8	19	10	66.5	80	94	10	*1
11	17	19	11	66.5	80	110	10	*1
12	18.3	19	12	66.5	80	111	10	*1
13	19.5	22	13	66.5	80	138	10	*2
14	20.8	22	14	66.5	80	148	10	*2
15	22	22	15	65.5	80	157	10	*2
16	23.3	22	16	65.5	80	156	10	*2
17	24.5	22	17	65.5	80	168	10	*2
18	25.8	22	18	64.5	80	190	10	*2
19	27	22	19	64.5	80	192	10	*2
20	28.3	22	20	64.5	80	224	10	*2
21	29.5	22	21	64.5	80	226	10	*2
22	30.8	22	22	63.5	80	231	10	*2
24	33.2	22	24	63.5	80	242	10	*2

13300A (inch)	D ₁ (mm)	D ₂ (mm)	ℓ (mm)	H (mm)	L (mm)	(g)	(pcs.)	
1/4	10.8	19	6	66.5	80	77	10	*1
5/16	13.3	19	8	66.5	80	82	10	*1
3/8	15.8	19	10	66.5	80	94	10	*1
7/16	17	19	11	66.5	80	110	10	*1
1/2	19.5	22	13	66.5	80	138	10	*2
9/16	20.8	22	14	66.5	80	148	10	*2
5/8	23.3	22	16	65.5	80	156	10	*2
11/16	24.5	22	17	65.5	80	168	10	*2
3/4	27	22	19	64.5	80	192	10	*2
13/16	29.5	22	21	64.5	80	226	10	*2
7/8	30.8	22	22	63.5	80	231	10	*2

*1 C-Ring=1301C, Pin/O-Ring=1301A/B
*2 C-Ring=1302C, Pin/O-Ring=1302A/B
→ P250-251

3/8"

Impact Sockets
Impact Steckschlüssel
Douilles Impact

Z-SERIES
HAND
TITANIUM
ACCESSORIES
SCREWDRIVERS
IMPACT
SLEEVE-DRIVE
PROTECTOR
INDUSTRIAL
AUTOMOTIVE
MOTORCYCLE
CONSTRUCTION
SPARE PART

13301M (mm)	D ₁ (mm)	D ₂ (mm)	ℓ (mm)	H (mm)	L (mm)	(g)	(pcs.)	Ⓢ
6	10	18.5	6	66.5	80	65	10	*1
7	11	18.5	7	66.5	80	66	10	*1
8	12.3	18.5	8	66.5	80	68	10	*1
9	13.5	18.5	9	66.5	80	70	10	*1
10	14.8	18.5	10	66.5	80	72	10	*1
11	16	18.5	11	66.5	80	80	10	*1
12	17.3	18.5	12	66.5	80	85	10	*1
13	18.5	21.5	13	66.5	80	100	10	*2
14	19.8	21.5	14	66.5	80	110	10	*2
15	21	21.5	15	65.5	80	120	10	*2
16	22.3	21.5	16	65.5	80	130	10	*2
17	23.5	21.5	17	65.5	80	136	10	*2
18	24.8	21.5	18	64.5	80	145	10	*2
19	26	21.5	19	64.5	80	155	10	*2
20	27.3	21.5	20	64.5	80	170	10	*2
21	28.5	21.5	21	64.5	80	181	10	*2
22	29.8	21.5	22	63.5	80	190	10	*2
New 24	32.3	21.5	24	63.5	80	216	10	*2

13301M Ⓢ 6-point Deep Socket, Thin Walled
13301A Ⓢ 6-kant Steckschlüssel, dünnwandig
Douilles à paroi mince longues, 6-pans

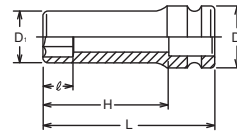

13301A (inch)	D ₁ (mm)	D ₂ (mm)	ℓ (mm)	H (mm)	L (mm)	(g)	(pcs.)	Ⓢ
1/4	10	18.5	6	66.5	80	65	10	*1
5/16	12.3	18.5	8	66.5	80	68	10	*1
3/8	14.8	18.5	10	66.5	80	72	10	*1
7/16	16	18.5	11	66.5	80	80	10	*1
1/2	18.5	21.5	13	66.5	80	100	10	*2
9/16	19.8	21.5	14	66.5	80	110	10	*2
5/8	22.3	21.5	16	65.5	80	130	10	*2
11/16	23.5	21.5	17	65.5	80	136	10	*2
3/4	26	21.5	19	64.5	80	155	10	*2
13/16	28.5	21.5	21	64.5	80	181	10	*2
7/8	29.8	21.5	22	63.5	80	190	10	*2

*1 C-Ring=1301C, Pin/O-Ring=1301A/B
*2 C-Ring=1302C, Pin/O-Ring=1302A/B

→ P250-251

13305M (mm)	D ₁ (mm)	D ₂ (mm)	ℓ (mm)	H (mm)	L (mm)	(g)	(pcs.)	Ⓢ
8	13.3	19	8	66.5	80	82	10	*1
10	15.8	19	10	66.5	80	94	10	*1
New 11	17	19	11	66.5	80	110	10	*1
12	18.3	19	12	66.5	80	111	10	*1
13	19.5	22	13	66.5	80	138	10	*2
14	20.8	22	14	66.5	80	148	10	*2
17	24.5	22	17	65.5	80	168	10	*2

*1 C-Ring=1301C, Pin/O-Ring=1301A/B
*2 C-Ring=1302C, Pin/O-Ring=1302A/B

→ P250-251

13305M Ⓢ 12-point Sockets, deep
12-kant Steckschlüssel, lang
Douilles longues, 12-pans

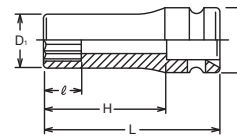

13306M (mm)	D ₁ (mm)	D ₂ (mm)	ℓ (mm)	H (mm)	L (mm)	(g)	(pcs.)	Ⓢ
New 8	12.3	18.5	8	66.5	80	68	10	*1
New 10	14.8	18.5	10	66.5	80	72	10	*1
New 11	16	18.5	11	66.5	80	80	10	*1
New 12	17.3	18.5	12	66.5	80	85	10	*1
New 13	18.5	21.5	13	66.5	80	100	10	*2
New 14	19.8	21.5	14	66.5	80	110	10	*2
New 17	23.5	21.5	17	66.5	80	136	10	*2

*1 C-Ring=1301C, Pin/O-Ring=1301A/B
*2 C-Ring=1302C, Pin/O-Ring=1302A/B

→ P250-251

13306M Ⓢ 12-point Deep Sockets, Thin Walled
12-kant Steckschlüssel, dünnwandig
Douilles à paroi mince longues, 12-pans

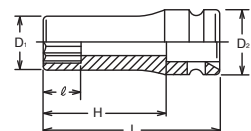

Impact Sockets

Impact Steckschlüssel

Douilles Impact

3/8"

Z-SERIES
HAND
TITANIUM
SCREWDRIVERS ACCESSORIES
IMPACT
SLEEVE-DRIVE
PROTECTOR
INDUSTRIAL
AUTOMOTIVE
MOTORCYCLE
CONSTRUCTION
SPARE PART

13300G

Impact Socket with Sliding Magnet
Impact Steckschlüssel mit versenkbarem Magnet
Douilles Impact avec aimant, glissant pour écrous

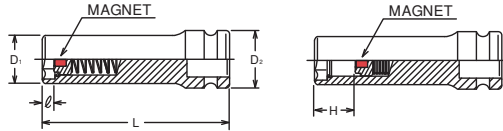

13300G (mm)	D ₁ (mm)	D ₂ (mm)	ℓ (mm)	H (mm)	L (mm)	(g)	(pcs.)	
8	13.3	19	4	26.5	80	82	10	*1
10	15.8	19	4.5	26	80	105	10	*1
12	18.3	19	6	26	80	136	10	*1
13	19.5	22	6.5	25	80	165	10	*2
14	20.8	22	7	24	80	186	10	*2
15	22	22	7	24	80	195	10	*2
New 16	23.3	22	8	27	80	210	10	*2
17	24.5	22	8	27	80	220	10	*2
19	27	22	9	28	80	230	10	*2

*1 C-Ring=1301C, Pin/O-Ring=1301A/B
*2 C-Ring=1302C, Pin/O-Ring=1302A/B
➔ P250-251

13310M

Surface Drive Sockets, deep
Surface Drive Steckschlüssel, lang
Douilles longues, Surface Drive

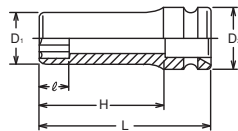

13310M (mm)	D ₁ (mm)	D ₂ (mm)	ℓ (mm)	H (mm)	L (mm)	(g)	(pcs.)	
7	12	19	7	66.5	80	77	10	*1
8	13.3	19	8	66.5	80	90	10	*1
9	14.5	19	9	66.5	80	90	10	*1
10	15.8	19	10	66.5	80	97	10	*1
11	17	19	11	66.5	80	110	10	*1
12	18.3	19	12	66.5	80	105	10	*1
13	19.5	22	13	66.5	80	135	10	*2
14	20.8	22	14	66.5	80	145	10	*2
15	22	22	15	65.5	80	160	10	*2
16	23.3	22	16	65.5	80	156	10	*2
17	24.5	22	17	65.5	80	168	10	*2
New 18	25.8	22	18	64.5	80	190	10	*2
19	27	22	19	64.5	80	190	10	*2

*1 C-Ring=1301C, Pin/O-Ring=1301A/B
*2 C-Ring=1302C, Pin/O-Ring=1302A/B
➔ P250-251

13365M

Pathfinder Sockets, deep
Pathfinder Steckschlüssel, lang
Douilles longues, Pathfinder

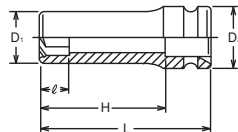

13365M (mm)	D ₁ (mm)	D ₂ (mm)	ℓ (mm)	H (mm)	L (mm)	(g)	(pcs.)	
New 8	13.3	19	7	66.5	80	90	10	*1
10	15.8	19	8	66.5	80	99	10	*1
11	17	19	8	66.5	80	108	10	*1
12	18.3	19	9	66.5	80	110	10	*1
13	19.5	22	9	66.5	80	142	10	*2
14	20.8	22	11	66.5	80	144	10	*2
15	22	22	11	65.5	80	150	10	*2
16	23.3	22	11	65.5	80	159	10	*2
17	24.5	22	12	65.5	80	170	10	*2
18	25.8	22	13	64.5	80	201	10	*2
19	27	22	13	64.5	80	203	10	*2

*1 C-Ring=1301C, Pin/O-Ring=1301A/B
*2 C-Ring=1302C, Pin/O-Ring=1302A/B
➔ P250-251

13325

TORX® Deep Sockets
TORX® Steckschlüssel, lang
Douilles longues TORX®

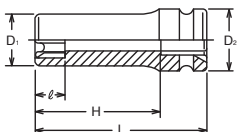

13325 (E)	D ₁ (mm)	D ₂ (mm)	ℓ (mm)	H (mm)	L (mm)	(g)	(pcs.)	
New E 7	11.2	19	6.6	66.5	80	75	10	*1
E 8	11.7	19	7	66.5	80	80	10	*1
E10	12.2	19	8.2	66.5	80	85	10	*1
E12	14.2	19	9.3	66.5	80	90	10	*1
E14	17.2	19	10.6	66.5	80	110	10	*1
E16	18.2	19	11.8	66.5	80	110	10	*1

*1 C-Ring=1301C, Pin/O-Ring=1301A/B
➔ P250-251

3/8"

Impact Sockets
Impact Steckschlüssel
Douilles Impact

Z-SERIES
HAND
TITANIUM
ACCESSORIES
SCREWDRIVERS
IMPACT
SLEEVE-DRIVE
PROTECTOR
INDUSTRIAL
AUTOMOTIVE
MOTORCYCLE
CONSTRUCTION
SPARE PART

13440M (mm)	D (mm)	ℓ (mm)	L (mm)	(g)	(pcs.)	⚡
10	15.8	5	57	115	10	*1
11	17	6	57	115	10	*1
12	18.3	6	57	115	10	*1
13	19.5	6	57	115	10	*1
14	20.8	7	59	120	10	*1
15	22	7	59	120	10	*1
16	23.3	8	59	120	10	*1
17	24.5	8	59	120	10	*1
18	25.8	9	61	126	10	*1
19	27	10	61	130	10	*1
20	29.5	10	61	135	10	*1
21	30.7	14	66	175	10	*1
22	32	13	66	185	10	*1
24	34.5	13	68	190	10	*1

13440A (inch)	D (mm)	ℓ (mm)	L (mm)	(g)	(pcs.)	⚡
3/8	15.8	5	57	115	10	*1
7/16	17	6	57	115	10	*1
1/2	19.5	6	57	115	10	*1
9/16	20.8	7	59	120	10	*1
5/8	23.3	8	59	120	10	*1
11/16	24.5	8	59	120	10	*1
3/4	27	10	61	130	10	*1

*1 C-Ring=1302C, Pin/O-Ring=1302A/B → P250-251

13440T (E)	D (mm)	ℓ (mm)	L (mm)	(g)	(pcs.)	⚡
E10	13.3	8.2	58	115	10	*1
E12	15.8	9.3	58	115	10	*1
E14	17	10.6	58	115	10	*1

*1 C-Ring=1302C, Pin/O-Ring=1302A/B → P250-251

13430M (mm)	D (mm)	ℓ (mm)	L (mm)	(g)	(pcs.)	⚡
5	24	15	74	120	10	*1
6	24	15	74	131	10	*1
8	24	20	74	136	10	*1
10	24	20	74	141	10	*1
17	24	7	53	150	10	*1

*1 C-Ring=1302C, Pin/O-Ring=1302A/B → P250-251

13440M / 13440A

Universal Sockets
Gelenk-Einsätze
Douilles universelles

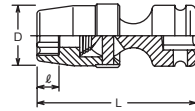

13440T

TORX® Universal Sockets
TORX® Gelenk-Einsätze
Douilles universelles TORX®

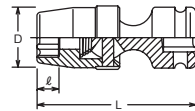

13430M

Universal Inhex Sockets
Gelenk-Einsätze für Schrauben mit Innensechskant
Douilles universelles 6-pans mâles

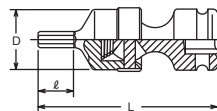

Impact Sockets Impact Steckschlüssel Douilles Impact

3/8"

13145M-100/-150/-200/-250

Extra Long Sockets
Schaftsteckschlüssel
Douilles, série allongée

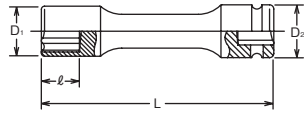

13145M-100 (mm)	D ₁ (mm)	D ₂ (mm)	ℓ (mm)	L (mm)	(g)	(pce.)	
8	13.3	19	8	100	90	1	*1
10	15.8	19	10	100	92	1	*1
12	18.3	19	12	100	100	1	*1
13	19.5	19	13	100	108	1	*1
14	20.8	19	14	100	112	1	*1
17	24.5	19	17	100	140	1	*1

13145M-150 (mm)	D ₁ (mm)	D ₂ (mm)	ℓ (mm)	L (mm)	(g)	(pce.)	
6	10.8	19	6	150	105	1	*1
8	13.3	19	8	150	110	1	*1
10	15.8	19	10	150	120	1	*1
12	18.3	19	12	150	128	1	*1
13	19.5	19	13	150	137	1	*1
14	20.8	19	14	150	146	1	*1
15	22	19	15	150	155	1	*1
17	24.5	19	17	150	163	1	*1

13145M-200 (mm)	D ₁ (mm)	D ₂ (mm)	ℓ (mm)	L (mm)	(g)	(pce.)	
6	10.8	19	6	200	136	1	*1
8	13.3	19	8	200	141	1	*1
10	15.8	19	10	200	151	1	*1
12	18.3	19	12	200	159	1	*1
13	19.5	19	13	200	168	1	*1
14	20.8	19	14	200	177	1	*1
15	22	19	15	200	186	1	*1
17	24.5	19	17	200	194	1	*1

13145M-250 (mm)	D ₁ (mm)	D ₂ (mm)	ℓ (mm)	L (mm)	(g)	(pce.)	
6	10.8	19	6	250	167	1	*1
8	13.3	19	8	250	172	1	*1
10	15.8	19	10	250	182	1	*1
12	18.3	19	12	250	190	1	*1
13	19.5	19	13	250	199	1	*1
14	20.8	19	14	250	208	1	*1
15	22	19	15	250	217	1	*1
17	24.5	19	17	250	225	1	*1

*1 C-Ring=1301C, Pin/O-Ring=1301A/B → P250-251

13145M-100 (12P)/-150 (12P)/-200 (12P)

Extra long 12-Point Sockets
Extra lange 12-kant Steckschlüssel
Douilles, série allongée 12 pans

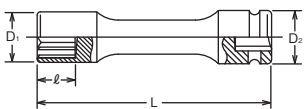

13145M-100 (12P) (mm)	D ₁ (mm)	D ₂ (mm)	ℓ (mm)	L (mm)	(g)	(pce.)	
10	15.8	19	10	100	91	1	*1
12	18.3	19	12	100	100	1	*1

13145M-150 (12P) (mm)	D ₁ (mm)	D ₂ (mm)	ℓ (mm)	L (mm)	(g)	(pce.)	
10	15.8	19	10	150	120	1	*1
12	18.3	19	12	150	128	1	*1

13145M-200 (12P) (mm)	D ₁ (mm)	D ₂ (mm)	ℓ (mm)	L (mm)	(g)	(pce.)	
10	15.8	19	10	200	151	1	*1
12	18.3	19	12	200	159	1	*1

*1 C-Ring=1301C, Pin/O-Ring=1301A/B → P250-251

13145MG-100/-150/-200

Extra Long Socket with Magnet
Schaftsteckschlüssel mit Magnet
Douilles, série allongée, avec aimant

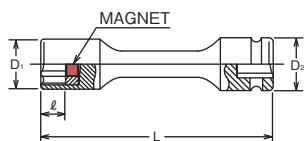

13145MG-100 (mm)	D ₁ (mm)	D ₂ (mm)	ℓ (mm)	L (mm)	(g)	(pce.)	
8	13.3	19	3.5	100	90	1	*1
10	15.8	19	4.2	100	93	1	*1
12	18.3	19	5.6	100	105	1	*1
13	19.5	19	6	100	115	1	*1
14	20.8	19	6.4	100	120	1	*1

13145MG-150 (mm)	D ₁ (mm)	D ₂ (mm)	ℓ (mm)	L (mm)	(g)	(pce.)	
10	15.8	19	4.2	150	125	1	*1
12	18.3	19	5.6	150	136	1	*1
13	19.5	19	6	150	145	1	*1
14	20.8	19	6.4	150	150	1	*1

13145MG-200 (mm)	D ₁ (mm)	D ₂ (mm)	ℓ (mm)	L (mm)	(g)	(pce.)	
10	15.8	19	4.2	200	182	1	*1
12	18.3	19	5.6	200	190	1	*1
13	19.5	19	6	200	208	1	*1
14	20.8	19	6.4	200	225	1	*1

*1 C-Ring=1301C, Pin/O-Ring=1301A/B → P250-251

Z-SERIES
HAND
TITANIUM
ACCESSORIES
SCREWDRIVERS
IMPACT
SLEEVE-DRIVE
PROTECTOR
INDUSTRIAL
AUTOMOTIVE
MOTORCYCLE
CONSTRUCTION
SPARE PART

13146M-150 (mm)	D ₁ (mm)	D ₂ (mm)	ℓ (mm)	L (mm)	(g)	(pce.)	⚡
8	12	19	6	150	128	1	*1
10	14.3	19	7	150	131	1	*1
12	18	19	8	150	133	1	*1
13	19.3	19	8.5	150	132	1	*1
14	20	19	9	150	132	1	*1

13146M-200 (mm)	D ₁ (mm)	D ₂ (mm)	ℓ (mm)	L (mm)	(g)	(pce.)	⚡
8	12	19	6	200	159	1	*1
10	14.3	19	7	200	162	1	*1
12	18	19	8	200	164	1	*1
13	19.3	19	8.5	200	163	1	*1
14	20	19	9	200	163	1	*1

13146M-250 (mm)	D ₁ (mm)	D ₂ (mm)	ℓ (mm)	L (mm)	(g)	(pce.)	⚡
8	12	19	6	250	190	1	*1
10	14.3	19	7	250	193	1	*1
12	18	19	8	250	195	1	*1
13	19.3	19	8.5	250	194	1	*1
14	20	19	9	250	194	1	*1

*1 C-Ring=1301C, Pin/O-Ring=1301A/B → P250-251

13146M-150/-200/-250

○ Extra Long Universal Sockets
Schäftsteckschlüssel mit Gelenk
Douilles, articulées, série allongée

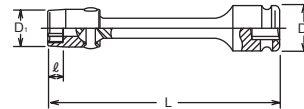

13147M-150 (mm)	D ₁ (mm)	D ₂ (mm)	ℓ (mm)	L (mm)	(g)	(pce.)	⚡
4	21	19	15	150	125	1	*1
5	21	19	15	150	128	1	*1
6	21	19	15	150	132	1	*1
8	21	19	15	150	136	1	*1
10	21	19	15	150	140	1	*1

13147M-200 (mm)	D ₁ (mm)	D ₂ (mm)	ℓ (mm)	L (mm)	(g)	(pce.)	⚡
4	21	19	15	200	156	1	*1
5	21	19	15	200	159	1	*1
6	21	19	15	200	163	1	*1
8	21	19	15	200	167	1	*1
10	21	19	15	200	171	1	*1

*1 C-Ring=1301C, Pin/O-Ring=1301A/B → P250-251

13147M-150/-200

● Extra Long Universal Inhex Sockets
Schäftsteckschlüssel mit Aussensechskant Gelenk
Douilles, articulées, à 6-pans mâle, série allongée

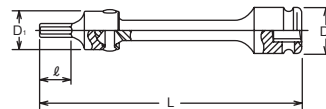

Impact Sockets Impact Steckschlüssel Douilles Impact

3/8"

Z-SERIES
HAND
TITANIUM
ACCESSORIES
SCREWDRIVERS
IMPACT
SLEEVE-DRIVE
PROTECTOR
INDUSTRIAL
AUTOMOTIVE
MOTORCYCLE
CONSTRUCTION
SPARE PART

13103M

Impact Stud Bolt Setters
Impact Stehbolzensetzer
Monte-goujons Impact

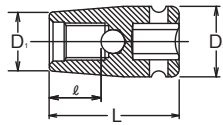

13103M (mm)	D ₁ (mm)	D ₂ (mm)	ℓ (mm)	L (mm)	(g)	(pcs.)	⚡
5(0.8)	9.5	19	8	32	39	10	*1
6(1.0)	10.8	19	9	32	41	10	*1
7(1.0)	12.5	19	10	32	44	10	*1
8(1.25)	13.5	19	10.5	35	49	10	*1
10(1.25)	15.8	19	13	35	49	10	*1
10(1.5)	15.8	19	13	35	49	10	*1

*1 C-Ring=1301C, Pin/O-Ring=1301A/B → P250-251

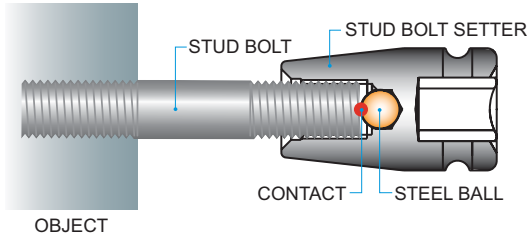

A special socket for installing a stud bolt.

Inside steel ball prevent the stud bolt stuck onto the socket. After installing a stud bolt, turn to anti-clockwise to removing the socket.

Spezialwerkzeug zum Setzen von Stehbolzen. Der Bolzen trifft im Werkzeug nur auf den Stahlbolzen, was die Kontaktfläche verringert. Nach dem Setzen des Stehbolzens kann das Werkzeug im Linkslauf vom Stehbolzen abgezogen werden.

Douilles spéciales pour monter les goujons.

Le goujon est en contact avec une bille d'acier pour l'empêcher d'adhérer à la douille. Après avoir posé le goujon, tourner dans le sens antihorlogique pour le retirer

13012M-52

Inhex Sockets
Steckschlüssel für Innensechskant-Schrauben
Douilles tournevis pour vis 6-pans creux

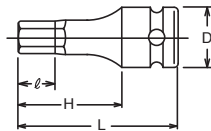

13012M-52 (mm)	D (mm)	ℓ (mm)	H (mm)	L (mm)	(g)	(pcs.)	⚡
3	18	10	34	52	33	10	*1
4	18	15.5	34	52	35	10	*1
5	18	15.5	34	52	35	10	*1
6	18	15.5	34	52	39	10	*1
7	18	15.5	34	52	44	10	*1
8	21	15.5	34	52	60	10	*2
10	21	15.5	34	52	70	10	*2
12	21	15.5	34	52	79	10	*2
14	21	15.5	34	52	92	10	*2

*1 C-Ring=1301C, Pin/O-Ring=1301A/B

*2 C-Ring=1302C, Pin/O-Ring=1302A/B → P250-251

RS13012M/8-L52

Socket Set on Rail
Steckschlüsselsatz auf Schiene
Jeu de douilles sur rail



RS13012M/8-L52	8 Pieces Set/Rail 200mm	(g)
4, 5, 6, 7, 8, 10, 12, 14		492

13025-50/-90

TORX® Bit Sockets
TORX® Bit-Steckschlüssel
Douilles tournevis, TORX®

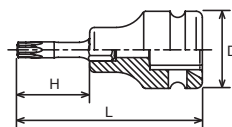

13025-50 (T)	D (mm)	H (mm)	L (mm)	(g)	(pcs.)	⚡
T20	19	23.5	50	35	10	*1
T25	19	23.5	50	35	10	*1
T27	19	23.5	50	35	10	*1
T30	19	23.5	50	35	10	*1
T40	19	23.5	50	39	10	*1
T45	19	23.5	50	60	10	*1
T50	19	23.5	50	70	10	*1
T55	22	23.5	50	79	10	*2

13025-90 (T)	D (mm)	H (mm)	L (mm)	(g)	(pcs.)	⚡
T20	19	63.5	90	43	10	*1
T25	19	63.5	90	45	10	*1
T27	19	63.5	90	47	10	*1
T30	19	63.5	90	50	10	*1
T40	19	63.5	90	58	10	*1
T45	19	63.5	90	66	10	*1
T50	19	63.5	90	80	10	*1
T55	22	63.5	90	120	10	*2

*1 C-Ring=1301C, Pin/O-Ring=1301A/B

*2 C-Ring=1302C, Pin/O-Ring=1302A/B → P250-251

RS13025/8-L50

Socket Set on Rail
Steckschlüsselsatz auf Schiene
Jeu de douilles sur rail



RS13025/8-L50	8 Pieces Set/Rail 200mm	(g)
T20, T25, T27, T30, T40, T45, T50, T55		380

	D (mm)	L (mm)	(g)	(pcs.)	
13134	22	32	70	10	*1

*1 C-Ring=1302C, Pin/O-Ring=1302A/B → P250-251

For DIN3126 E11.2 Bits
Für DIN3126 E11.2 Bits
Pour DIN3126 E11.2 Embouts

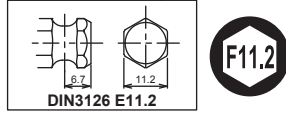

13134-SC



Replacement Screw : M8x5, ● 4mm
Ersatzschraube : M8x5, ● 4mm
Vis de remplacement : M8x5, ● 4mm

	D ₁ (mm)	D ₂ (mm)	L (mm)	(g)	(pcs.)	
13142-F11.2	18.9	22	46	116	10	*1

*1 C-Ring=1302C, Pin/O-Ring=1302A/B → P250-251

For DIN3126 E11.2 Bits
Für DIN3126 E11.2 Bits
Pour DIN3126 E11.2 Embouts

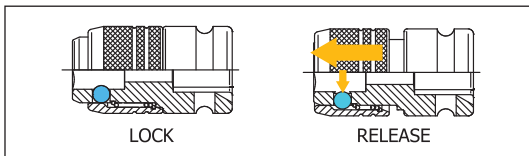
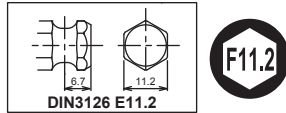

13134 ○ Impact Bit Holder Impact Klingenhalter Porte embouts Impact

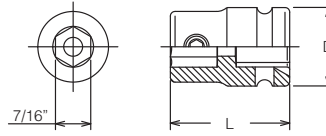

13142-F11.2 ○ Impact Bit Holder (Quick Release) Impact Klingenhalter (Quick Release) Porte embouts Impact (Quick Release)

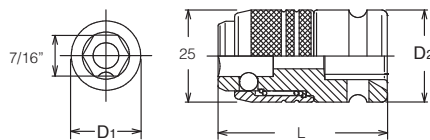

183H-35/-75/-150 ● Hex Bits Sechskant Bits Embouts, 6 pans creux

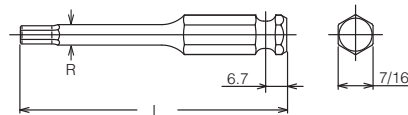

	183H-35 (inch)	L (mm)	(g)	(pcs.)
New	3/16	35	15	10
New	7/32	35	16	10
New	1/4	35	18	10
New	5/16	35	20	10
New	3/8	35	26	10
New	7/16	35	28	10
New	1/2	35	38	10

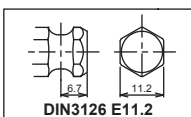

	183H-35 (mm)	L (mm)	(g)	(pcs.)
	3	35	15	10
	4	35	15	10
	5	35	15	10
	6	35	18	10
New	7	35	19	10
	8	35	20	10
	10	35	26	10
New	11	35	28	10
	12	35	30	10
	14	35	35	10
New	16	35	47	10
New	17	35	50	10
New	18	35	53	10
New	19	35	56	10

	183H-75 (mm)	L (mm)	R (mm)	(g)	(pcs.)
	3	75	6.0	34	10
	4	75	6.0	35	10
	5	75	6.5	36	10
	6	75	7.5	39	10
New	7	75	8.5	44	10
	8	75	9.5	47	10
	10	75	-	57	10
New	11	75	-	60	10
	12	75	-	65	10
	14	75	-	79	10

	183H-150 (mm)	L (mm)	R (mm)	(g)	(pcs.)
	4	150	6.0	51	10
	5	150	6.5	55	10
	6	150	7.5	65	10
	8	150	9.5	87	10
	10	150	-	118	10
	12	150	-	136	10

Impact Sockets
Impact Steckschlüssel
Douilles Impact

3/8"

Z-SERIES
HAND
TITANIUM
SCREWDRIVERS ACCESSORIES
IMPACT
SLEEVE-DRIVE
PROTECTOR
INDUSTRIAL
AUTOMOTIVE
MOTORCYCLE
CONSTRUCTION
SPARE PART

183T-35/-75/-150 (T)

 TORX® Bits
TORX® Bits
Embouts, TORX®

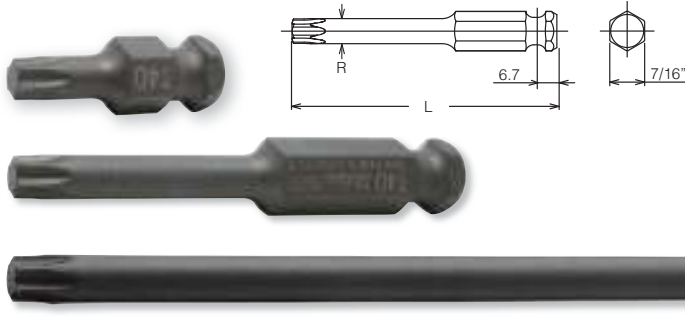

183T-35 (T)	L (mm)	(g)	(pcs.)
T25	35	18	10
T30	35	18	10
T40	35	20	10
T45	35	22	10
T50	35	26	10
T55	35	30	10
T60	35	38	10

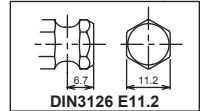

183T-150 (T)	L (mm)	R (mm)	(g)	(pcs.)
T30	150	6.0	50	10
T40	150	6.9	58	10
T45	150	8.0	70	10
T50	150	9.0	82	10
T55	150	11.4	113	10

183T-75 (T)	L (mm)	R (mm)	(g)	(pcs.)
T30	75	6.0	35	10
T40	75	6.9	37	10
T45	75	8.0	41	10
T50	75	9.0	45	10
T55	75	11.4	55	10
T60	75	13.5	67	10

183T-35/-75 (IP)

 TORXPLUS® Bits
TORXPLUS® Bits
Embouts TORXPLUS®

TORXplus

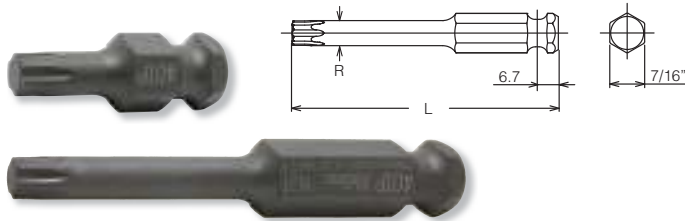

183T-35 (IP)	L (mm)	(g)	(pcs.)
30IP	35	18	10
40IP	35	20	10
45IP	35	22	10
50IP	35	26	10
55IP	35	30	10
60IP	35	38	10

183T-75 (IP)	L (mm)	R (mm)	(g)	(pcs.)
30IP	75	6.0	35	10
40IP	75	6.8	37	10
45IP	75	8.0	41	10
50IP	75	9.0	45	10
55IP	75	11.4	56	10
60IP	75	13.5	67	10

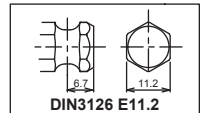

183X-35/-75/-150 (XZN)

 XZN Bits
XZN Bits
Embouts, XZN

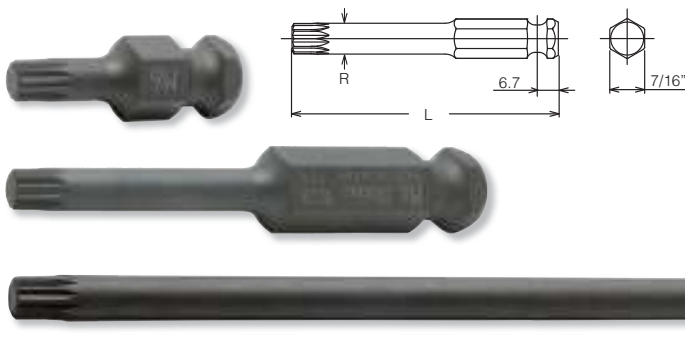

183X-35 (XZN)	L (mm)	(g)	(pcs.)
M 4	35	18	10
M 5	35	18	10
M 6	35	20	10
M 8	35	22	10
M10	35	26	10
M12	35	30	10
M14	35	38	10

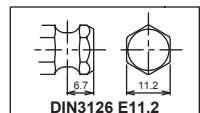

183X-75 (XZN)	L (mm)	R (mm)	(g)	(pcs.)
M 4	75	6.0	34	10
M 5	75	6.0	34	10
M 6	75	6.2	36	10
M 8	75	7.4	39	10
M10	75	9.8	54	10
M12	75	11.7	57	10
M14	75	13.5	67	10

183X-150 (XZN)	L (mm)	R (mm)	(g)	(pcs.)
M 5	150	6.0	50	10
M 6	150	6.2	53	10
M 8	150	7.4	64	10
M10	150	9.8	93	10
M12	150	11.7	121	10

13134M-52/-92 (mm)	D (mm)	H (mm)	L (mm)	L (mm)	R (mm)	L=52 (g)	L=92 (g)	L=52/92 (pcs.)	⊕
New 3	22	20.6	52	92	6.0	85	104	10	*1
New 4	22	20.6	52	92	6.0	85	105	10	*1
New 5	22	20.6	52	92	6.5	85	106	10	*1
New 6	22	20.6	52	92	7.5	88	109	10	*1
New 8	22	20.6	52	92	9.5	90	117	10	*1
New 10	22	20.6	52	92	-	96	127	10	*1
New 12	22	20.6	52	92	-	100	135	10	*1
New 14	22	20.6	52	92	-	105	149	10	*1

*1 C-Ring=1302C, Pin/O-Ring=1302A/B → P250-251

13134T-52/-92 (T)	D (mm)	H (mm)	L (mm)	L (mm)	R (mm)	L=52 (g)	L=92 (g)	L=52/92 (pcs.)	⊕
New T30	22	20.6	52	92	6.0	88	105	10	*1
New T40	22	20.6	52	92	6.9	90	107	10	*1
New T45	22	20.6	52	92	8.0	92	111	10	*1
New T50	22	20.6	52	92	9.0	96	115	10	*1
New T55	22	20.6	52	92	11.4	100	125	10	*1
New T60	22	20.6	52	92	13.5	108	137	10	*1

*1 C-Ring=1302C, Pin/O-Ring=1302A/B → P250-251

13134T-52/-92 (IP)	D (mm)	H (mm)	L (mm)	L (mm)	R (mm)	L=52 (g)	L=92 (g)	L=52/92 (pcs.)	⊕
New 30IP	22	20.6	52	92	6.0	88	105	10	*1
New 40IP	22	20.6	52	92	6.8	90	107	10	*1
New 45IP	22	20.6	52	92	8.0	92	111	10	*1
New 50IP	22	20.6	52	92	9.0	96	115	10	*1
New 55IP	22	20.6	52	92	11.4	100	126	10	*1
New 60IP	22	20.6	52	92	13.5	108	139	10	*1

*1 C-Ring=1302C, Pin/O-Ring=1302A/B → P250-251

13134X-52/-92 (XZN)	D (mm)	H (mm)	L (mm)	L (mm)	R (mm)	L=52 (g)	L=92 (g)	L=52/92 (pcs.)	⊕
New M 5	22	20.6	52	92	6.0	88	104	10	*1
New M 6	22	20.6	52	92	6.2	90	106	10	*1
New M 8	22	20.6	52	92	7.4	92	109	10	*1
New M10	22	20.6	52	92	9.8	96	124	10	*1
New M12	22	20.6	52	92	11.7	100	129	10	*1
New M14	22	20.6	52	92	13.5	108	139	10	*1

*1 C-Ring=1302C, Pin/O-Ring=1302A/B → P250-251

13134M-52/-92

Bit Holder complete with Bit, Inhex
Klingenhalter komplett mit Klinge, Innensechskant
Porte embouts avec bit 6-pans creux

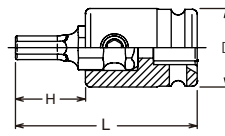

13134T-52/-92 (T)

Bit Holder complete with TORX® Bit
Klingenhalter, komplett mit TORX® Klinge
Porte embouts avec bit TORX®

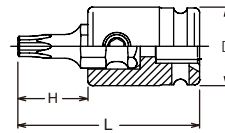

13134T-52/-92 (IP)

Bit Holder complete with TORXPLUS® Bit
Klingenhalter, komplett mit TORXPLUS® Klinge
Porte embouts avec bit TORXPLUS®

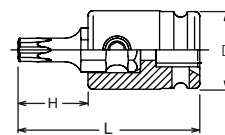

13134X-52/-92 (XZN)

Bit Holder complete with XZN Bit
Klingenhalter, komplett mit XZN Klinge
Porte embouts avec bit XZN

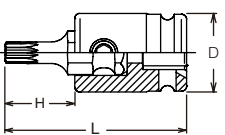

Impact Sockets Impact Steckschlüssel Douilles Impact

3/8"

Z-SERIES
HAND
TITANIUM
SCREWDRIVERS ACCESSORIES
IMPACT
SLEEVE-DRIVE
PROTECTOR
INDUSTRIAL
AUTOMOTIVE
MOTORCYCLE
CONSTRUCTION
SPARE PART

13139 ○ Bit Holder Klingenhalter Porte-embout

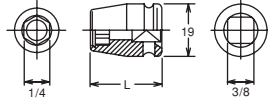

	D ₁ (mm)	D ₂ (mm)	L (mm)	(g)	(pcs.)	⚡
13139-1/4	11	19	30	32	10	*1

*1 C-Ring=1301C, Pin/O-Ring=1301A/B → P250-251

For DIN3126 C6.3 Bits
Für DIN3126 C6.3 Bits
Pour DIN3126 C6.3 Embouts

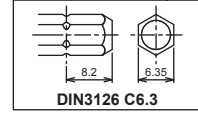

13140 ○ Bit Holder Klingenhalter Porte-embout

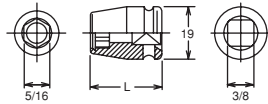

	D ₁ (mm)	D ₂ (mm)	L (mm)	(g)	(pcs.)	⚡
13140-5/16	14	19	30	32	10	*1

*1 C-Ring=1301C, Pin/O-Ring=1301A/B → P250-251

For DIN3126 C8 Bits
Für DIN3126 C8 Bits
Pour DIN3126 C8 Embouts

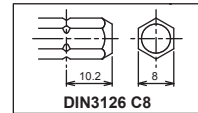

13142-D6.3 ○ Impact Bit Holder (Quick Release) Impact Kingenhalter (Schnellwechselfutter) Porte embout Impact (mandrin autoserrant)

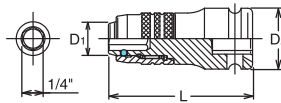

	D ₁ (mm)	D ₂ (mm)	L (mm)	(g)	(pcs.)	⚡
13142-D6.3	16	19	45	60	10	*1

*1 C-Ring=1301C, Pin/O-Ring=1301A/B → P250-251

For DIN3126 C6.3 Bits
Für DIN3126 C6.3 Bits
Pour DIN3126 C6.3 Embouts

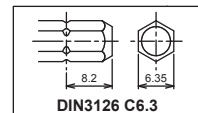

13142-F6.3 ○ Impact Bit Holder (Quick Release) Impact Kingenhalter (Schnellwechselfutter) Porte embout Impact (mandrin autoserrant)

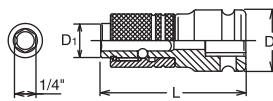

	D ₁ (mm)	D ₂ (mm)	L (mm)	(g)	(pcs.)	⚡
13142-F6.3	16.5	19	45	60	10	*1

*1 C-Ring=1301C, Pin/O-Ring=1301A/B → P250-251

For DIN3126 E6.3 Bits
Für DIN3126 E6.3 Bits
Pour DIN3126 E6.3 Embouts

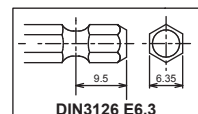

Lock & Quick Release

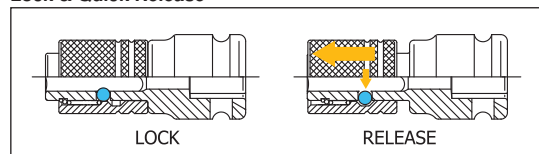

	TYPE	D (mm)	L (mm)	(g)	(pcs.)		
	13760-50P	Pin	22	50	70	10	*1
New	13760-50	Hole	22	50	70	10	*1
	13760-75P	Pin	22	75	95	10	*1
New	13760-75	Hole	22	75	95	10	*1
	13760-100P	Pin	22	100	115	10	*1
New	13760-100	Hole	22	100	115	10	*1
	13760-125P	Pin	22	125	140	10	*1
New	13760-125	Hole	22	125	140	10	*1
	13760-150P	Pin	22	150	165	10	*1
New	13760-150	Hole	22	150	165	10	*1
	13760-200P	Pin	22	200	215	10	*1
New	13760-200	Hole	22	200	215	10	*1
	13760-250P	Pin	22	250	260	10	*1
New	13760-250	Hole	22	250	260	10	*1

*1 C-Ring=1302C, Pin/O-Ring=1302A/B → P250-251

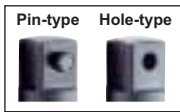

13760-P 13760

Extension Bars
Verlängerungen
Rallonges

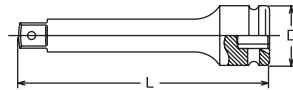

	L (mm)	(g)	(pcs.)	
13333AL	45	62	10	*1

*1 C-Ring=1301C, Pin/O-Ring=1301A/B → P250-251

Lock & Quick Release

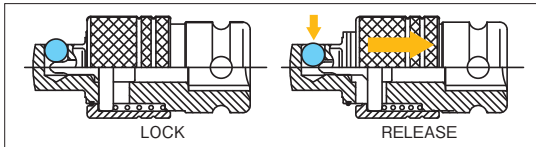

13333AL

Adaptor (Quick Release)
Verbindungsstück (Quick Release)
Adaptateur (Quick Release)

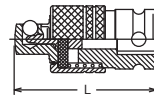

Impact Sockets Impact Steckschlüssel Douilles Impact

3/8"

Z-SERIES
HAND
TITANIUM
SCREWDRIVERS ACCESSORIES
IMPACT
SLEEVE-DRIVE
PROTECTOR
INDUSTRIAL
AUTOMOTIVE
CONSTRUCTION MOTORCYCLE
SPARE PART

13770-P 13770

Universal Joint
Gelenk-Einsatz
Joint articlé

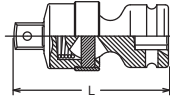

13771-P 13771

Universal Joint
Gelenk-Einsatz
Joint articlé

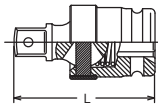

13772-P

Universal Double Joint
Doppelgelenk-Einsatz
Joint articlé double



13322A-P 13322A

Adaptor
Verbindungsstück
Réducteur

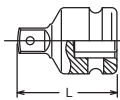

13344A-P 13344A

Adaptor
Verbindungsstück
Augmentateur

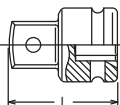

13241M

Socket Set
Steckschlüssel Satz
Jeu de clés à douilles



13242M

Socket Set
Steckschlüssel Satz
Jeu de clés à douilles



	TYPE	L (mm)	(g)	(pcs.)	(V)
	13770-P Pin	56	110	10	*1
New	13770 Hole	56	110	10	*1
	13771-P Pin	48	92	10	*1
New	13771 Hole	48	92	10	*1

*1 C-Ring=1302C, Pin/O-Ring=1302A/B → P250-251

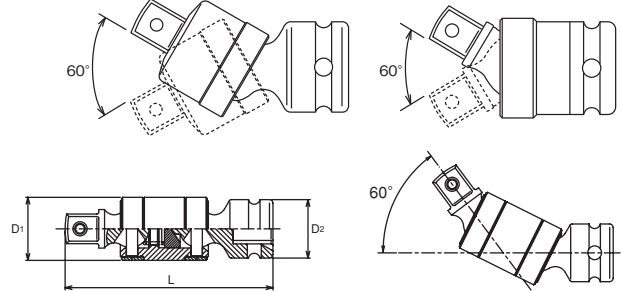
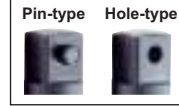

	D1 (mm)	D2 (mm)	L (mm)	(g)	(pcs.)	(V)
	13772-P 22	19	75	120	5	*1

*1 C-Ring=1301C, Pin/O-Ring=1301A/B → P250-251

Make sure sockets hold bolts or nuts before operation.

Vergewissern Sie sich vor dem Gebrauch, dass der Steckschlüssel die Schraube sicher umfasst hat.

Avant la manipulation, il est nécessaire de s'assurer que la douille renferme parfaitement la vis.



	TYPE	(sq.)	(sq.)	L (mm)	(g)	(pcs.)	(V)
	13322A-P Pin	3/8"	1/4"	27	25	10	*1
New	13322A Hole	3/8"	1/4"	27	25	10	*1

*1 C-Ring=1301C, Pin/O-Ring=1301A/B → P250-251

Adapting down from bigger square drive to smaller square drive may lead to excessive torque load and possibly cause breakage. Always stay within safe torque of the smaller square drive.

Die mit gekennzeichneten Artikel können bei Überbelastung zu Bruch gehen. Aus Gründen Ihrer eigenen Sicherheit sollten die betreffenden Werkzeuge nie ruckartig, sondern nach und nach belastet werden, um Bruch und damit verbundene mögliche Verletzungen zu vermeiden.

Il est possible d'appliquer aux articles marqués des couples de serrage susceptibles d'occasionner leur rupture. Pour votre propre sécurité, veuillez toujours appliquer la charge d'une manière uniforme et progressive. Ceci pour éviter ruptures et accidents.

	TYPE	(sq.)	(sq.)	L (mm)	(g)	(pcs.)	(V)
	13344A-P Pin	3/8"	1/2"	32.5	53	10	*1
New	13344A Hole	3/8"	1/2"	32.5	53	10	*1

*1 C-Ring=1302C, Pin/O-Ring=1302A/B → P250-251

13241M 11 Pieces Set/△=850g
METAL CASE:W240xH30xT35mm

Sockets
 13400M 6-pt. Sockets
9, 10, 11, 12, 13, 14, 15, 16, 17, 18, 19

13242M 11 Pieces Set/△=1,140g
METAL CASE:W310xH90xT48mm

Sockets
 13400M 6-pt. Sockets
9, 10, 11, 12, 13, 14, 15, 16, 17, 18, 19

14401MS (mm)	D ₁ (mm)	D ₂ (mm)	ℓ (mm)	L (mm)	(g)	(pcs.)	(V)
14	20.5	24	10	29	50	10	*1
17	24.2	29	10	29	85	10	*2
19	26.7	29	10	29	85	10	*2
22	30.5	29	10	29	90	10	*2
24	33	29	10	29	90	10	*2

*1 C-Ring=1401C, Pin/O-Ring=1401A/B
*2 C-Ring=1402C, Pin/O-Ring=1402A/B
➔ P250-251

RS14401MS/5	5 Pieces Set/Rail 150mm	(g)
14, 17, 19, 22, 24		420

14400MG (mm)	D ₁ (mm)	D ₂ (mm)	ℓ (mm)	L (mm)	(g)	(pcs.)	(V)
8	14.5	25	3.5	38	95	10	*1
10	17	25	4.2	38	95	10	*1
12	19.5	25	5.6	38	100	10	*1
13	20.7	25	6	38	100	10	*1
14	22	25	6.4	38	105	10	*1
15	23.2	30	6.8	38	140	10	*2
16	24.5	30	7	38	145	10	*2
17	25.7	30	7.5	38	145	10	*2
18	27	30	7.8	38	147	10	*2
19	28.2	30	8	38	147	10	*2
21	30.7	30	8	38	165	10	*2

*1 C-Ring=1401C, Pin/O-Ring=1401A/B
*2 C-Ring=1402C, Pin/O-Ring=1402A/B
➔ P250-251

14401LH (LH-S)	D ₁ (mm)	D ₂ (mm)	ℓ (mm)	L (mm)	(g)	(pcs.)	(V)
6S	13	25	5.6	38	65	10	*1
8S	16.7	25	6.8	38	69	10	*1
10S	19.2	25	8	38	75	10	*1
12S	23	30	9.2	38	115	10	*2
14S	25.5	30	10.4	38	121	10	*2
16S	29.2	30	11.6	38	128	10	*2

*1 C-Ring=1401C, Pin/O-Ring=1401A/B
*2 C-Ring=1402C, Pin/O-Ring=1402A/B
➔ P250-251

14410M (mm)	D ₁ (mm)	D ₂ (mm)	ℓ (mm)	L (mm)	(g)	(pcs.)	(V)
10	17	25	7	38	100	10	*1
11	18.2	25	8	38	103	10	*1
12	19.5	25	9	38	110	10	*1
13	20.7	25	10	38	113	10	*1
14	22	25	10	38	115	10	*1
15	23.2	30	11	38	120	10	*2
16	24.5	30	11	38	120	10	*2
17	25.7	30	12	38	126	10	*2
18	27	30	13	38	121	10	*2
19	28.2	30	13	38	124	10	*2
20	29.5	30	13	38	123	10	*2
21	30.7	30	14	38	120	10	*2
22	32	30	14	38	130	10	*2
24	34.5	30	14	38	134	10	*2
25	35.7	30	14	38	135	10	*2
26	37	30	14	38	160	10	*2
27	38.2	30	16	40	160	10	*2
28	39.5	30	16	40	170	10	*2
29	40.7	30	17	42	190	10	*2
30	42	30	17	42	190	10	*2
31	43.2	30	17	42	213	10	*2
32	44.5	30	18	42	216	10	*2
34	47	30	19	46	263	5	*2
36	49.5	30	20	46	285	5	*2

*1 C-Ring=1401C, Pin/O-Ring=1401A/B
*2 C-Ring=1402C, Pin/O-Ring=1402A/B
➔ P250-251

14401MS 6-point short sockets, Thin Walled 6-kant Steckschlüssel kurz, dünnwandig Douilles 6-pans courtes, à paroi mince

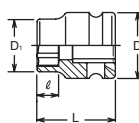

RS14401MS/5 Socket Set on Rail Steckschlüsselsatz auf Schiene Jeu de douilles sur rail



14400MG 6-point Sockets with Magnet 6-kant Steckschlüssel mit Magnet Douilles 6-pans avec aimant

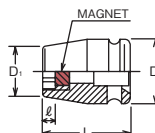

14401LH LHS Sockets Steckschlüssel mit LHS Profil Douilles au profil LHS

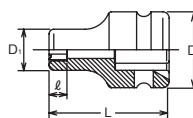

14410M Surface Drive Sockets Surface Drive Steckschlüssel Douilles, Surface Drive

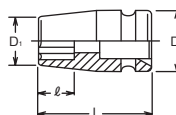

SURFACE DRIVE

Surface drive sockets are designed to retain contact with the flat sides of the nut in order to transmit higher torque and reduce nut wear. These sockets are ideal for using on polished nuts, aluminum nuts and nuts with worn out points.

Das Profil unserer Surface-Drive Steckschlüssel greift die Schraube an deren Flächen. Dies sichert eine höhere Kraftübertragung und verhindert ein Durchrutschen des Steckschlüssels. Diese Steckschlüssel eignen sich besonders für polierte Schrauben, Aluminium Schrauben und Schrauben bei denen die Ecken bereits abgerundet sind.

Notre profil Surface Drive assure le contact entre la douille et les plats de l'écrou. Ceci réduit l'usure et permet la transmission d'un couple plus élevé. C'est une solution idéale pour les écrous polies, celles en aluminium ou arrondies.

Impact Sockets Impact Steckschlüssel Douilles Impact

1/2"

Z-SERIES
HAND
TITANIUM
SCREWDRIVERS ACCESSORIES
IMPACT
SLEEVE-DRIVE
PROTECTOR
INDUSTRIAL
AUTOMOTIVE
MOTORCYCLE
CONSTRUCTION
SPARE PART

14465M Pathfinder Sockets Pathfinder Steckschlüssel Douilles Pathfinder

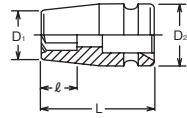

PATHFINDER®

The beveled flats of the 6-points opening of the PATHFINDER socket engage the nut almost immediately. PATHFINDER sockets are ideal for using with power tools in automatic assembly processes, as the power tool does not have to be totally stopped for the socket to engage the nut.

Da die Maschine nicht nach jedem Schraubvorgang angehalten werden muss, ergibt sich eine erhöhte Produktivität, die sich bei vollautomatischen Maschinen (Mehrspindelschrauber) ganz besonders auswirkt.

Les parois en biais des douilles en 6-pans Pathfinder assurent l'engagement quasi immédiat de l'écrou. Le fait de ne pas devoir arrêter la machine après chaque serrage, engendre une productivité supérieure dans les chaînes de montage automatiques.

14415M Double 4-point Socket Doppelvierkant Steckschlüssel Douilles 4-pans, doubles

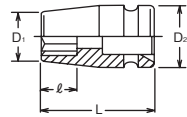

14425 TORX® Sockets TORX® Steckschlüssel Douilles TORX®

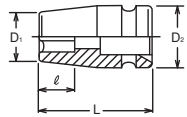

14425-EPL TORXPLUS® Sockets TORXPLUS® Steckschlüssel Douilles TORXPLUS®

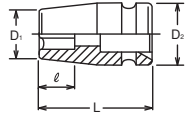

14400-WN Weld Nut Sockets Steckschlüssel für Schweißmutter Douille pour écrou à souder

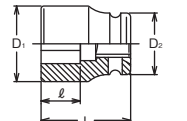

14465M (mm)	D ₁ (mm)	D ₂ (mm)	ℓ (mm)	L (mm)	(g)	(pcs.)	
10	17	25	8	38	89	10	*1
11	18.2	25	8	38	87	10	*1
12	19.5	25	9	38	87	10	*1
13	20.7	25	9	38	86	10	*1
14	22	25	11	38	86	10	*1
15	23.2	30	11	38	131	10	*2
16	24.5	30	11	38	131	10	*2
17	25.7	30	12	38	132	10	*2
18	27	30	13	38	128	10	*2
19	28.2	30	13	38	128	10	*2
20	29.5	30	14	38	125	10	*2
21	30.7	30	14	38	128	10	*2
22	32	30	15	38	130	10	*2
23	33.2	30	15	38	135	10	*2
24	34.5	30	15	38	135	10	*2
26	37	30	15	38	152	10	*2
27	38.2	30	16	40	169	10	*2

*1 C-Ring=1401C, Pin/O-Ring=1401A/B
*2 C-Ring=1402C, Pin/O-Ring=1402A/B

14415M (mm)	D ₁ (mm)	D ₂ (mm)	ℓ (mm)	L (mm)	(g)	(pcs.)	
14	25.7	30	10	38	138	10	*1
15	27	30	11	38	145	10	*1
16	29.5	30	11	38	150	10	*1
17	30.7	30	12	38	155	10	*1
18	32	30	13	38	165	10	*1
19	33.2	30	14	38	170	10	*1
22	38.2	30	14	40	185	10	*1
24	42	30	14	42	215	10	*1
27	45.7	30	16	46	278	5	*1
28	47	30	16	46	285	5	*1
29	49.5	30	17	46	326	5	*2

*1 C-Ring=1402C, Pin/O-Ring=1402A/B

14425 (E)	D ₁ (mm)	D ₂ (mm)	ℓ (mm)	L (mm)	(g)	(pcs.)	
E10	14.2	25	8.2	38	86	10	*1
E11	14.7	25	8.7	38	86	10	*1
E12	15.2	25	9.3	38	85	10	*1
E14	18.2	25	10.6	38	88	10	*1
E16	19.2	25	11.8	38	88	10	*1
E18	22.2	25	13	40	89	10	*1
E20	24.2	30	14.4	40	134	10	*2
E22	26.2	30	15.5	40	140	10	*2
E24	28.2	30	17	42	138	10	*2

*1 C-Ring=1401C, Pin/O-Ring=1401A/B
*2 C-Ring=1402C, Pin/O-Ring=1402A/B

14425 (EPL)	D ₁ (mm)	D ₂ (mm)	ℓ (mm)	L (mm)	(g)	(pcs.)	
10EPL	14.5	25	6.2	38	86	10	*1
12EPL	17	25	7.2	38	86	10	*1
14EPL	18.2	25	8.1	38	88	10	*1
16EPL	20.7	25	9.1	38	88	10	*1
18EPL	22	25	10.2	38	90	10	*1
20EPL	24.5	30	11.2	38	135	10	*2

*1 C-Ring=1401C, Pin/O-Ring=1401A/B
*2 C-Ring=1402C, Pin/O-Ring=1402A/B

14400-WN	D ₁ (mm)	D ₂ (mm)	ℓ (mm)	L (mm)	(g)	(pcs.)	
8WN	18.3	25	8	38	93	10	*1
9WN	19.5	25	9	38	93	10	*1
10WN	20.8	25	10	38	92	10	*1
12WN	24.5	30	12	38	139	10	*2
14WN	27	30	14	38	136	10	*2
17WN	32	30	17	40	150	10	*2

*1 C-Ring=1401C, Pin/O-Ring=1401A/B
*2 C-Ring=1402C, Pin/O-Ring=1402A/B

TORX® is a registered trademark of Acument Intellectual Properties, LLC.
TORX® ist ein registriertes Markenzeichen der Firma Acument Intellectual Properties, LLC.
TORX® est une marque déposée de Acument Intellectual Properties, LLC.

TORXplus® is a registered trademark of Acument Intellectual Properties, LLC.
TORXplus® ist ein registriertes Markenzeichen der Firma Acument Intellectual Properties, LLC.
TORXplus® est une marque déposée de Acument Intellectual Properties, LLC.

1/2"

Impact Sockets
Impact Steckschlüssel
Douilles Impact

14301X (mm)	D ₁ (mm)	D ₂ (mm)	ℓ (mm)	H (mm)	L (mm)	(g)	(pcs.)	⚡
8	13	24	8	42	60	72	10	*1
9	14.2	24	9	42	60	75	10	*1
10	15.5	24	10	42	60	79	10	*1
11	16.7	24	11	42	60	82	10	*1
12	18	24	12	42	60	88	10	*1
13	19.2	24	13	42	60	92	10	*1
14	20.5	24	14	42	60	97	10	*1
15	21.7	29	15	42	60	125	10	*2
16	23	29	16	42	60	135	10	*2
17	24.2	29	17	42	60	142	10	*2
18	25.5	29	18	42	60	148	10	*2
19	26.7	29	19	41	60	151	10	*2
21	29.2	29	21	41	60	170	10	*2
22	30.5	29	22	45	65	187	10	*2
23	31.7	29	23	45	65	192	10	*2
24	33	29	24	45	65	202	10	*2
25	34.2	29	25	44	65	210	10	*2
26	35.5	29	26	44	65	218	10	*2
27	36.7	29	27	44	65	231	10	*2
30	40.5	29	30	44	65	268	10	*2
32	43	29	32	44	65	296	10	*2
33	44.2	29	33	44	65	318	2	*2
34	45.5	29	34	44	65	330	2	*2
36	48	29	36	44	65	350	2	*2

*1 C-Ring=1401C, Pin/O-Ring=1401A/B
*2 C-Ring=1402C, Pin/O-Ring=1402A/B
→ P250-251

RS14301X/10	10 Pieces Set/Rail 300mm	(g)
10, 12, 13, 14, 17, 19, 21, 22, 24, 27		1,585

14300M (mm)	D ₁ (mm)	D ₂ (mm)	ℓ (mm)	H (mm)	L (mm)	(g)	(pcs.)	⚡
8	14.5	25	8	62	80	137	10	*1
9	15.7	25	9	62	80	138	10	*1
10	17	25	10	62	80	140	10	*1
11	18.2	25	11	62	80	156	10	*1
12	19.5	25	12	62	80	162	10	*1
13	20.7	25	13	62	80	162	10	*1
14	22	25	14	62	80	174	10	*1
15	23.2	30	15	62	80	220	10	*2
16	24.5	30	16	62	80	232	10	*2
17	25.7	30	17	62	80	232	10	*2
18	27	30	18	62	80	232	10	*2
19	28.2	30	19	61	80	259	10	*2
20	29.5	30	20	61	80	265	10	*2
21	30.7	30	21	61	80	265	10	*2
22	32	30	22	65	85	290	10	*2
23	33.2	30	23	65	85	300	10	*2
24	34.5	30	24	65	85	329	10	*2
25	35.7	30	25	65	85	345	10	*2
26	37	30	26	64	85	350	10	*2
27	38.2	30	27	64	85	385	10	*2
28	39.5	30	28	64	85	390	10	*2
29	40.7	30	29	63	85	416	10	*2
30	42	30	30	63	85	457	10	*2
31	43.2	30	31	63	85	505	10	*2
32	44.5	30	32	63	85	542	10	*2
33	45.7	30	33	62	85	562	2	*2
34	47	30	33	62	85	570	2	*2
35	48.2	30	35	62	85	600	2	*2
36	49.5	30	36	61	85	640	2	*2
38	52	30	38	60	85	655	2	*2
41	55.7	30	38	60	85	690	2	*2

*1 C-Ring=1401C, Pin/O-Ring=1401A/B
*2 C-Ring=1402C, Pin/O-Ring=1402A/B
→ P250-251

14301X ○ 6-point Semi-Deep Socket, Thin Walled
6-kant Steckschlüssel mittel lang, dünnwandig
Douilles à paroi mince semi-longues, 6-pans

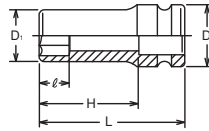

RS14301X/10 ○ Socket Set on Rail
Steckschlüsselsatz auf Schiene
Jeu de douilles sur rail



14300M / 14300A ○ 6-point Deep Sockets
6-kant-Steckschlüssel lang
Douilles longues 6-pans

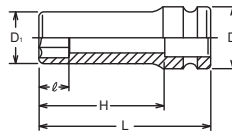

14300A (inch)	D ₁ (mm)	D ₂ (mm)	ℓ (mm)	H (mm)	L (mm)	(g)	(pcs.)	⚡
5/16	14.5	25	8	62	80	137	10	*1
3/8	17	25	10	62	80	140	10	*1
7/16	18.2	25	11	62	80	156	10	*1
1/2	20.7	25	13	62	80	162	10	*1
9/16	22	25	14	62	80	174	10	*1
5/8	24.5	30	16	62	80	232	10	*2
11/16	25.7	30	17	62	80	232	10	*2
3/4	28.2	30	19	61	80	259	10	*2
13/16	30.7	30	21	61	80	265	10	*2
7/8	32	30	22	65	85	290	10	*2
15/16	34.5	30	24	65	85	329	10	*2
1	35.7	30	25	65	85	345	10	*2
1. 1/16	38.2	30	27	64	85	385	10	*2
1. 1/8	40.7	30	29	63	85	416	10	*2
1. 3/16	42	30	30	63	85	457	10	*2
1. 1/4	44.5	30	32	63	85	542	10	*2
1. 7/16	50.7	30	37	61	85	580	2	*2
1. 1/2	52	30	38	61	85	600	2	*2

*1 C-Ring=1401C, Pin/O-Ring=1401A/B
*2 C-Ring=1402C, Pin/O-Ring=1402A/B
→ P250-251

Z-SERIES
HAND
TITANIUM
ACCESSORIES
SCREWDRIVERS
IMPACT
SLEEVE-DRIVE
PROTECTOR
INDUSTRIAL
AUTOMOTIVE
MOTORCYCLE CONSTRUCTION
SPARE PART

14310M (mm)	D ₁ (mm)	D ₂ (mm)	ℓ (mm)	H (mm)	L (mm)	(g)	(pcs.)	Ⓢ
10	17	25	10	62	80	136	10	*1
11	18.2	25	11	62	80	148	10	*1
12	19.5	25	12	62	80	156	10	*1
13	20.7	25	13	62	80	158	10	*1
14	22	25	14	62	80	170	10	*1
15	23.2	30	15	62	80	225	10	*2
16	24.5	30	16	62	80	228	10	*2
17	25.7	30	17	62	80	232	10	*2
18	27	30	18	62	80	232	10	*2
19	28.2	30	19	61	80	252	10	*2
20	29.5	30	20	61	80	260	10	*2
21	30.7	30	21	61	80	260	10	*2
22	32	30	22	65	85	290	10	*2
23	33.2	30	23	65	85	300	10	*2
24	34.5	30	24	65	85	322	10	*2
25	35.7	30	25	65	85	338	10	*2
26	37	30	26	64	85	350	10	*2
27	38.2	30	27	64	85	380	10	*2
28	39.5	30	28	64	85	390	10	*2
29	40.7	30	29	63	85	416	10	*2
30	42	30	30	63	85	450	10	*2
31	43.2	30	31	63	85	505	10	*2
32	44.5	30	32	63	85	535	10	*2
34	47	30	34	62	85	563	2	*2
36	49.5	30	36	61	85	630	2	*2

*1 C-Ring=1401C, Pin/O-Ring=1401A/B
*2 C-Ring=1402C, Pin/O-Ring=1402A/B

14300G (mm)	D ₁ (mm)	D ₂ (mm)	ℓ (mm)	H (mm)	L (mm)	(g)	(pcs.)	Ⓢ
10	17	25	4.5	26	80	139	10	*1
12	19.5	25	6	26	80	165	10	*1
13	20.7	25	6.5	25	80	185	10	*1
14	22	25	7	24	80	189	10	*1
15	23.2	30	7	24	80	240	10	*2
16	24.5	30	7.5	26.5	80	270	10	*2
17	25.7	30	8	26.5	80	272	10	*2
18	27	30	8.5	26.5	80	290	10	*2
19	28.2	30	9	27.5	80	308	10	*2

*1 C-Ring=1401C, Pin/O-Ring=1401A/B
*2 C-Ring=1402C, Pin/O-Ring=1402A/B

14365M (mm)	D ₁ (mm)	D ₂ (mm)	ℓ (mm)	H (mm)	L (mm)	(g)	(pcs.)	Ⓢ
10	17	25	8	62	80	138	10	*1
11	18.2	25	8	62	80	144	10	*1
12	19.5	25	9	62	80	165	10	*1
13	20.7	25	9	62	80	170	10	*1
14	22	25	11	62	80	178	10	*1
15	23.2	30	11	62	80	237	10	*2
16	24.5	30	11	62	80	245	10	*2
17	25.7	30	12	62	80	263	10	*2
18	27	30	13	62	80	268	10	*2
19	28.2	30	13	61	80	270	10	*2
20	29.5	30	14	61	80	274	10	*2
21	30.7	30	14	61	80	287	10	*2
22	32	30	15	65	85	314	10	*2
23	33.2	30	15	65	85	320	10	*2
24	34.5	30	15	65	85	335	10	*2
26	37	30	15	64	85	388	10	*2
27	38.2	30	16	64	85	407	10	*2

*1 C-Ring=1401C, Pin/O-Ring=1401A/B
*2 C-Ring=1402C, Pin/O-Ring=1402A/B

14325 (E)	D ₁ (mm)	D ₂ (mm)	ℓ (mm)	H (mm)	L (mm)	(g)	(pcs.)	Ⓢ
E10	14.2	25	8.2	62	80	136	10	*1
E12	15.2	25	9.3	62	80	141	10	*1
E14	18.2	25	10.6	62	80	147	10	*1
E16	19.2	25	11.8	62	80	151	10	*1
E18	22.2	25	13	62	80	218	10	*1
E20	24.2	30	14.4	62	80	225	10	*2

*1 C-Ring=1401C, Pin/O-Ring=1401A/B
*2 C-Ring=1402C, Pin/O-Ring=1402A/B

14310M



Surface Drive Sockets, deep
Surface Drive Steckschlüssel, lang
Douilles longues, Surface Drive

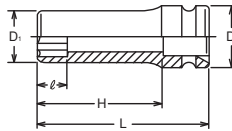

14300G



Impact Socket with Sliding Magnet
Impact Steckschlüssel mit versenkbarem Magnet
Douilles Impact avec aimant, glissant pour écrous

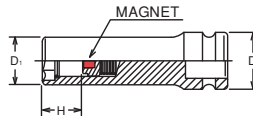
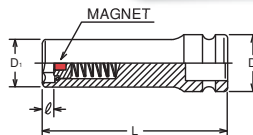

14365M



Pathfinder Sockets, deep
Pathfinder Steckschlüssel, lang
Douilles longues, Pathfinder

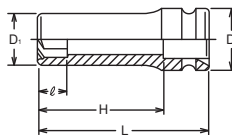

14325



TORX® Deep Sockets
TORX® Steckschlüssel, lang
Douilles longues TORX®

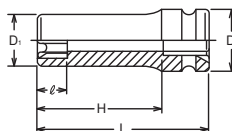

Impact Sockets Impact Steckschlüssel Douilles Impact

1/2"

Z-SERIES
HAND
TITANIUM
SCREWDRIVERS ACCESSORIES
IMPACT
SLEEVE-DRIVE
PROTECTOR
INDUSTRIAL
AUTOMOTIVE
MOTORCYCLE
CONSTRUCTION
SPARE PART

14440M / 14440A

Universal Sockets
Gelenk-Einsätze
Douilles universelles

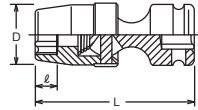

14100M / 14100A

Impact Screw and Stud Pullers
Impact Stehbolzenendreher
Extracteurs de goujons Impact

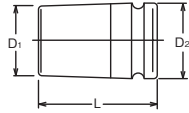

Hexagon body design can lessen the excessive load on cages and rollers inside the pullers.

Der neue Körper mit sechs Walzenmulden verteilt den Druck auf den Käfig und die Walzen weitaus vorteilhafter.

La forme hexagonale du corps améliore les tolérances.

Elle répartit l'effort de façon plus uniforme sur la cage et les rouleaux.

14103M

Impact Stud Bolt Setters
Impact Stehbolzensetzer
Monte-goujons Impact

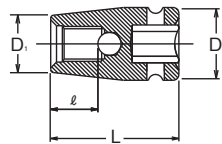

A special socket for installing a stud bolt. Inside steel ball prevent the stud bolt stuck onto the socket. After installing a stud bolt, turn to anti-clockwise to removing the socket.

Spezialwerkzeug zum Setzen von Stehbolzen. Der Bolzen trifft im Werkzeug nur auf den Stahlbolzen, was die Kontaktfläche verringert. Nach dem Setzen des Stehbolzens kann das Werkzeug im Linkslauf vom Stehbolzen abgezogen werden.

Douilles spéciales pour monter les goujons. Le goujon est en contact avec une bille d'acier pour l'empêcher d'adhérer à la douille. Après avoir posé le goujon, tourner dans le sens antihorlogique pour le retirer

14440M (mm)	D (mm)	ℓ (mm)	L (mm)	(g)	(pcs.)	
13	20.7	6	67.5	210	10	*1
14	22	7	69.5	210	10	*1
15	23.2	7	69.5	210	10	*1
16	24.5	8	69.5	206	10	*1
17	25.7	8	69.5	220	10	*1
18	27	9	69.5	218	10	*1
19	28.2	10	73.5	260	10	*1
20	29.5	10	73.5	270	10	*1
21	30.7	11	73.5	280	10	*1
22	32	13	73.5	290	10	*1
24	34.5	14	73.5	300	10	*1

14440A (inch)	D (mm)	ℓ (mm)	L (mm)	(g)	(pcs.)	
1/2	20.7	6	67.5	210	10	*1
9/16	22	7	69.5	210	10	*1
5/8	24.5	8	69.5	206	10	*1
11/16	25.7	8	69.5	220	10	*1
3/4	28.2	10	73.5	260	10	*1

*1 C-Ring=1402C, Pin/O-Ring=1402A/B → P250-251

14100M (mm)	D1 (mm)	D2 (mm)	L (mm)	(g)	(pcs.)	
6	24	25	48	126	10	*1
7	24	25	48	126	10	*1
8	24	25	48	122	10	*1
9	28	30	48	181	10	*2
10	28	30	48	181	10	*2
12	28	30	48	175	10	*2

14100A (inch)	D1 (mm)	D2 (mm)	L (mm)	(g)	(pcs.)	
1/4	24	25	48	126	10	*1
5/16	24	25	48	122	10	*1
3/8	28	30	48	181	10	*2
7/16	28	30	48	181	10	*2
1/2	28	30	48	180	10	*2

*1 C-Ring=1401C, Pin/O-Ring=1401A/B
*2 C-Ring=1402C, Pin/O-Ring=1402A/B → P250-251

Tolerance

	14100M (mm)		14100A (inch)
6	5.6- 6	1/4	6 - 6.4
7	6.6- 7	5/16	7.6- 8
8	7.6- 8	3/8	9 - 9.6
9	8.4- 9	7/16	10.5-11.1
10	9.4-10	1/2	12.1-12.7
12	11.4-12		

14103M (mm)	D1 (mm)	D2 (mm)	ℓ (mm)	L (mm)	(g)	(pcs.)	
6(1.0)	12	25	10	42	75	10	*1
7(1.0)	13.2	25	11.4	42	78	10	*1
8(1.25)	14.5	25	11.5	42	81	10	*1
10(1.25)	17	25	13.5	49	106	10	*1
10(1.5)	17	25	13.5	49	106	10	*1
12(1.25)	19.5	25	15.5	49	107	10	*1
12(1.75)	19.5	25	15.5	49	107	10	*1
14(1.5)	22	25	18.2	55	128	10	*1
14(2.0)	22	25	18.2	55	128	10	*1

*1 C-Ring=1401C, Pin/O-Ring=1401A/B → P250-251

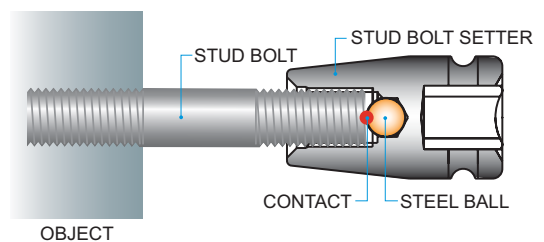

14145M-100 (mm)	D ₁ (mm)	D ₂ (mm)	ℓ (mm)	L (mm)	(g)	(pce.)	⚡
10	17	25	10	100	155	1	*1
12	19.5	25	12	100	165	1	*1
14	22	25	14	100	180	1	*1
17	25.7	25	17	100	210	1	*1
19	28.2	25	19	100	230	1	*1

14145M-150 (mm)	D ₁ (mm)	D ₂ (mm)	ℓ (mm)	L (mm)	(g)	(pce.)	⚡
10	17	25	10	150	190	1	*1
12	19.5	25	12	150	204	1	*1
13	20.7	25	13	150	216	1	*1
14	22	25	14	150	228	1	*1
15	23.2	25	15	150	240	1	*1
16	24.5	25	16	150	245	1	*1
17	25.7	25	17	150	253	1	*1
18	27	25	18	150	260	1	*1
19	28.2	25	19	150	267	1	*1

14145M-200 (mm)	D ₁ (mm)	D ₂ (mm)	ℓ (mm)	L (mm)	(g)	(pce.)	⚡
10	17	25	10	200	234	1	*1
12	19.5	25	12	200	248	1	*1
13	20.7	25	13	200	260	1	*1
14	22	25	14	200	272	1	*1
15	23.2	25	15	200	284	1	*1
16	24.5	25	16	200	290	1	*1
17	25.7	25	17	200	297	1	*1
18	27	25	18	200	305	1	*1
19	28.2	25	19	200	311	1	*1

*1 C-Ring=1401C, Pin/O-Ring=1401A/B → P250-251

14145M-250 (mm)	D ₁ (mm)	D ₂ (mm)	ℓ (mm)	L (mm)	(g)	(pce.)	⚡
10	17	25	10	250	278	1	*1
12	19.5	25	12	250	292	1	*1
13	20.7	25	13	250	304	1	*1
14	22	25	14	250	316	1	*1
15	23.2	25	15	250	328	1	*1
16	24.5	25	16	250	335	1	*1
17	25.7	25	17	250	341	1	*1
18	27	25	18	250	350	1	*1
19	28.2	25	19	250	355	1	*1

*1 C-Ring=1401C, Pin/O-Ring=1401A/B → P250-251

14145M-100/-150/-200/-250

○ Extra Long Sockets
Schäftsteckschlüssel
Douilles, série allongée

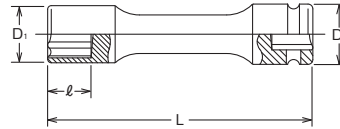

Impact Sockets Impact Steckschlüssel Douilles Impact

1/2"

Z-SERIES
HAND
TITANIUM
SCREWDRIVERS ACCESSORIES
IMPACT
SLEEVE-DRIVE
PROTECTOR
INDUSTRIAL
AUTOMOTIVE
CONSTRUCTION MOTORCYCLE
SPARE PART

14146M-150/-200/-250



Extra Long Universal Sockets
Schaftsteckschlüssel mit Gelenk
Douilles, articulées, série allongée



14146M-150 (mm)	D ₁ (mm)	D ₂ (mm)	ℓ (mm)	L (mm)	(g)	(pce.)	Ⓢ
10	16	25	6.5	150	197	1	*1
12	19.3	25	7.5	150	200	1	*1
13	20	25	8	150	201	1	*1
14	21	25	8.5	150	203	1	*1
15	22	25	9	150	201	1	*1
16	23	25	9.5	150	200	1	*1
17	25	25	9.5	150	200	1	*1
18	26	25	11	150	210	1	*1
19	28	25	11.5	150	210	1	*1

14146M-200 (mm)	D ₁ (mm)	D ₂ (mm)	ℓ (mm)	L (mm)	(g)	(pce.)	Ⓢ
10	16	25	6.5	200	241	1	*1
12	19.3	25	7.5	200	244	1	*1
13	20	25	8	200	245	1	*1
14	21	25	8.5	200	247	1	*1
15	22	25	9	200	245	1	*1
16	23	25	9.5	200	244	1	*1
17	25	25	9.5	200	244	1	*1
18	26	25	11	200	250	1	*1
19	28	25	11.5	200	254	1	*1

*1 C-Ring=1401C, Pin/O-Ring=1401A/B → P250-251

14146M-250 (mm)	D ₁ (mm)	D ₂ (mm)	ℓ (mm)	L (mm)	(g)	(pce.)	Ⓢ
10	16	25	6.5	250	285	1	*1
12	19.3	25	7.5	250	288	1	*1
13	20	25	8	250	289	1	*1
14	21	25	8.5	250	291	1	*1
15	22	25	9	250	289	1	*1
16	23	25	9.5	250	288	1	*1
17	25	25	9.5	250	288	1	*1
18	26	25	11	250	290	1	*1
19	28	25	11.5	250	299	1	*1

*1 C-Ring=1401C, Pin/O-Ring=1401A/B → P250-251

14147M-150/-200



Extra Long Universal Inhex Sockets
Schaftsteckschlüssel mit Aussensechskant Gelenk
Douilles, articulées, à 6-pans mâle, série allongée

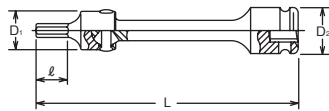

14147M-150 (mm)	D ₁ (mm)	D ₂ (mm)	ℓ (mm)	L (mm)	(g)	(pce.)	Ⓢ
6	25	25	15	150	200	1	*1
8	25	25	15	150	205	1	*1
10	25	25	15	150	210	1	*1
12	25	25	15	150	217	1	*1

14147M-200 (mm)	D ₁ (mm)	D ₂ (mm)	ℓ (mm)	L (mm)	(g)	(pce.)	Ⓢ
6	25	25	15	200	244	1	*1
8	25	25	15	200	249	1	*1
10	25	25	15	200	254	1	*1
12	25	25	15	200	261	1	*1

*1 C-Ring=1401C, Pin/O-Ring=1401A/B → P250-251

14012M-60 (mm)	D (mm)	ℓ (mm)	H (mm)	L (mm)	(g)	(pcs.)	⚡
4	25	15.5	38	60	68	10	*1
5	25	15.5	38	60	71	10	*1
6	25	15.5	38	60	74	10	*1
7	25	15.5	38	60	80	10	*1
8	25	15.5	38	60	84	10	*1
10	30	15.5	38	60	140	10	*2
12	30	15.5	38	60	150	10	*2
14	30	15.5	38	60	170	10	*2
New 16	30	15.5	38	60	180	10	*2
17	30	15.5	38	60	190	10	*2
19	30	15.5	38	60	210	10	*2

*1 C-Ring=1401C, Pin/O-Ring=1401A/B
*2 C-Ring=1402C, Pin/O-Ring=1402A/B **→ P250-251**

RS14012M/10-L60	10 Pieces Set/Rail 300mm	(g)
4, 5, 6, 7, 8, 10, 12, 14, 17, 19		1,300

14012M-60

Inhex Sockets
Steckschlüssel für Innensechskant-Schrauben
Douilles tournevis pour vis 6-pans creux

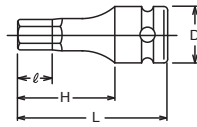

RS14012M/10-L60

Socket Set on Rail
Steckschlüsselsatz auf Schiene
Jeu de douilles sur rail



14025-60 (T)	D (mm)	H (mm)	L (mm)	(g)	(pcs.)	⚡
T20	25	23.5	60	75	10	*1
T25	25	23.5	60	75	10	*1
T27	25	23.5	60	75	10	*1
T30	25	23.5	60	80	10	*1
T40	25	23.5	60	85	10	*1
T45	25	23.5	60	85	10	*1
T50	25	23.5	60	95	10	*1
T55	25	23.5	60	110	10	*1
T60	30	23.5	60	160	10	*2

14025-100 (T)	D (mm)	H (mm)	L (mm)	(g)	(pcs.)	⚡
T30	25	73.5	100	85	10	*1
T40	25	73.5	100	95	10	*1
T45	25	73.5	100	102	10	*1
T50	25	73.5	100	120	10	*1
T55	25	73.5	100	155	10	*1
T60	30	73.5	100	220	10	*2

*1 C-Ring=1401C, Pin/O-Ring=1401A/B
*2 C-Ring=1402C, Pin/O-Ring=1402A/B **→ P250-251**

14025-60/-100

TORX® Bit Sockets
TORX® Bit-Steckschlüssel
Douilles tournevis, TORX®

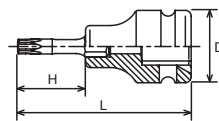

RS14025/6-L60	6 Pieces Set/Rail 200mm	(g)
T30, T40, T45, T50, T55, T60		650

RS14025/6-L60

Socket Set on Rail
Steckschlüsselsatz auf Schiene
Jeu de douilles sur rail



Impact Sockets Impact Steckschlüssel Douilles Impact

1/2"

Z-SERIES

HAND

TITANIUM

SCREWDRIVERS

ACCESSORIES

IMPACT

SLEEVE-DRIVE

PROTECTOR

INDUSTRIAL

AUTOMOTIVE

MOTORCYCLE

CONSTRUCTION

SPARE PART

14134 ○ Impact Bit Holder Impact Klingenhalter Porte embouts Impact

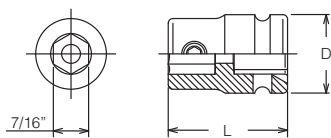

	D (mm)	L (mm)	(g)	(pcs.)	⚡
14134	25	38	90	10	*1

*1 C-Ring=1401C, Pin/O-Ring=1401A/B → P250-251

For DIN3126 E11.2 Bits
Für DIN3126 E11.2 Bits
Pour DIN3126 E11.2 Embouts

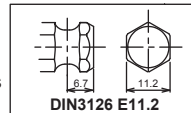

DIN3126 E11.2

13134-SC



Replacement Screw : M8x5, ● 4mm
Ersatzschraube : M8x5, ● 4mm
Vis de remplacement : M8x5, ● 4mm

14142-F11.2 ○ Impact Bit Holder (Quick Release) Impact Klingenhalter (Quick Release) Porte embouts Impact (Quick Release)

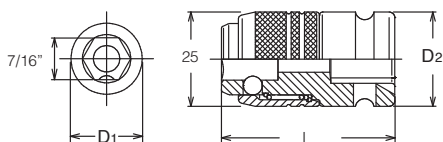

	D1 (mm)	D2 (mm)	L (mm)	(g)	(pcs.)	⚡
14142-F11.2	18.9	25	46	207	10	*1

*1 C-Ring=1401C, Pin/O-Ring=1401A/B → P250-251

For DIN3126 E11.2 Bits
Für DIN3126 E11.2 Bits
Pour DIN3126 E11.2 Embouts

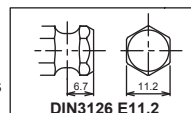

DIN3126 E11.2

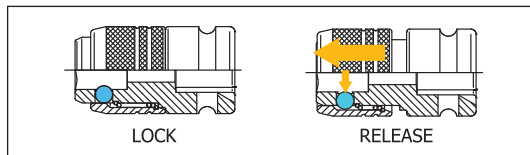

183H-35/-75/-150 ○ Hex Bits Sechskant Bits Embouts, 6 pans creus

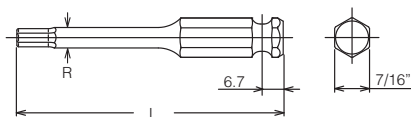

	183H-35 (inch)	L (mm)	(g)	(pcs.)
New	3/16	35	15	10
New	7/32	35	16	10
New	1/4	35	18	10
New	5/16	35	20	10
New	3/8	35	26	10
New	7/16	35	28	10
New	1/2	35	38	10

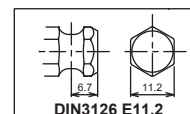

DIN3126 E11.2

	183H-35 (mm)	L (mm)	(g)	(pcs.)
	3	35	15	10
	4	35	15	10
	5	35	15	10
	6	35	18	10
New	7	35	19	10
	8	35	20	10
	10	35	26	10
New	11	35	28	10
	12	35	30	10
	14	35	35	10
New	16	35	47	10
New	17	35	50	10
New	18	35	53	10
New	19	35	56	10

	183H-75 (mm)	L (mm)	R (mm)	(g)	(pcs.)
	3	75	6.0	34	10
	4	75	6.0	35	10
	5	75	6.5	36	10
	6	75	7.5	39	10
New	7	75	8.5	44	10
	8	75	9.5	47	10
	10	75	-	57	10
New	11	75	-	60	10
	12	75	-	65	10
	14	75	-	79	10

	183H-150 (mm)	L (mm)	R (mm)	(g)	(pcs.)
	4	150	6.0	51	10
	5	150	6.5	55	10
	6	150	7.5	65	10
	8	150	9.5	87	10
	10	150	-	118	10
	12	150	-	136	10

1/2"

Impact Sockets
Impact Steckschlüssel
Douilles Impact

183T-35/-75/-150 (T)

TORX® Bits
TORX® Bits
Embouts, TORX®

183T-35 (T)	L (mm)	(g)	(pcs.)
T25	35	18	10
T30	35	18	10
T40	35	20	10
T45	35	22	10
T50	35	26	10
T55	35	30	10
T60	35	38	10

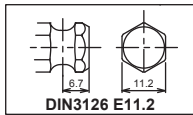
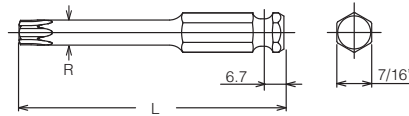

183T-75 (T)	L (mm)	R (mm)	(g)	(pcs.)
T30	75	6.0	35	10
T40	75	6.9	37	10
T45	75	8.0	41	10
T50	75	9.0	45	10
T55	75	11.4	55	10
T60	75	13.5	67	10

183T-150 (T)	L (mm)	R (mm)	(g)	(pcs.)
T30	150	6.0	50	10
T40	150	6.9	58	10
T45	150	8.0	70	10
T50	150	9.0	82	10
T55	150	11.4	113	10

183T-35/-75 (IP)

TORXPLUS® Bits
TORXPLUS® Bits
Embouts TORXPLUS®

TORXplus

183T-35 (IP)	L (mm)	(g)	(pcs.)
30IP	35	18	10
40IP	35	20	10
45IP	35	22	10
50IP	35	26	10
55IP	35	30	10
60IP	35	38	10

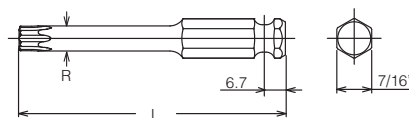

183T-75 (IP)	L (mm)	R (mm)	(g)	(pcs.)
30IP	75	6.0	35	10
40IP	75	6.8	37	10
45IP	75	8.0	41	10
50IP	75	9.0	45	10
55IP	75	11.4	56	10
60IP	75	13.5	67	10

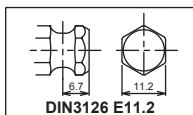

183X-35/-75/-150 (XZN)

XZN Bits
XZN Bits
Embouts, XZN

183X-35 (XZN)	L (mm)	(g)	(pcs.)
M 4	35	18	10
M 5	35	18	10
M 6	35	20	10
M 8	35	22	10
M10	35	26	10
M12	35	30	10
M14	35	38	10

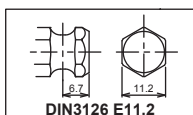
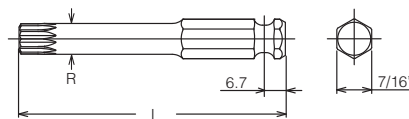

183X-75 (XZN)	L (mm)	R (mm)	(g)	(pcs.)
M 4	75	6.0	34	10
M 5	75	6.0	34	10
M 6	75	6.2	36	10
M 8	75	7.4	39	10
M10	75	9.8	54	10
M12	75	11.7	57	10
M14	75	13.5	67	10

183X-150 (XZN)	L (mm)	R (mm)	(g)	(pcs.)
M 5	150	6.0	50	10
M 6	150	6.2	53	10
M 8	150	7.4	64	10
M10	150	9.8	93	10
M12	150	11.7	121	10

Impact Sockets Impact Steckschlüssel Douilles Impact

1/2"

Z-SERIES
HAND
TITANIUM
SCREWDRIVERS
ACCESSORIES
IMPACT
SLEEVE-DRIVE
PROTECTOR
INDUSTRIAL
AUTOMOTIVE
CONSTRUCTION
MOTORCYCLE
SPARE PART

14134M-58/-98

Bit Holder complete with Bit, Inhex
Klingenhälter komplett mit Klinge, Innensechskant
Porte embouts avec bit 6-pans creux

14134M-58/-98 (mm)	D (mm)	H (mm)	L (mm)	L (mm)	R (mm)	L=58 (g)	L=98 (g)	L=58 (pcs.)	L=98 (pcs.)	Ⓢ
New 3	25	20.6	58	98	6.0	105	124	10	5	*1
New 4	25	20.6	58	98	6.0	105	125	10	5	*1
New 5	25	20.6	58	98	6.5	105	126	10	5	*1
New 6	25	20.6	58	98	7.5	108	129	10	5	*1
New 8	25	20.6	58	98	9.5	110	137	10	5	*1
New 10	25	20.6	58	98	-	116	147	10	5	*1
New 12	25	20.6	58	98	-	120	155	10	5	*1
New 14	25	20.6	58	98	-	125	169	10	5	*1



*1 C-Ring=1401C, Pin/O-Ring=1401A/B → P250-251

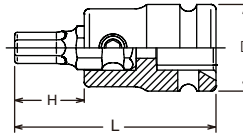

14134T-58/-98 (T)

Bit Holder complete with TORX® Bit
Klingenhälter, komplett mit TORX® Klinge
Porte embouts avec bit TORX®

14134T-58/-98 (T)	D (mm)	H (mm)	L (mm)	L (mm)	R (mm)	L=58 (g)	L=98 (g)	L=58 (pcs.)	L=98 (pcs.)	Ⓢ
New T30	25	20.6	58	98	6.0	108	125	10	5	*1
New T40	25	20.6	58	98	6.9	110	127	10	5	*1
New T45	25	20.6	58	98	8.0	112	131	10	5	*1
New T50	25	20.6	58	98	9.0	116	135	10	5	*1
New T55	25	20.6	58	98	11.4	120	145	10	5	*1
New T60	25	20.6	58	98	13.5	128	157	10	5	*1



*1 C-Ring=1401C, Pin/O-Ring=1401A/B → P250-251

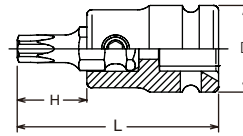

14134T-58/-98 (IP)

Bit Holder complete with TORXPLUS® Bit
Klingenhälter, komplett mit TORXPLUS® Klinge
Porte embouts avec bit TORXPLUS®

14134T-58/-98 (IP)	D (mm)	H (mm)	L (mm)	L (mm)	R (mm)	L=58 (g)	L=98 (g)	L=58 (pcs.)	L=98 (pcs.)	Ⓢ
New 30IP	25	20.6	58	98	6.0	108	125	10	5	*1
New 40IP	25	20.6	58	98	6.8	110	127	10	5	*1
New 45IP	25	20.6	58	98	8.0	112	131	10	5	*1
New 50IP	25	20.6	58	98	9.0	116	135	10	5	*1
New 55IP	25	20.6	58	98	11.4	120	146	10	5	*1
New 60IP	25	20.6	58	98	13.5	128	159	10	5	*1



*1 C-Ring=1401C, Pin/O-Ring=1401A/B → P250-251

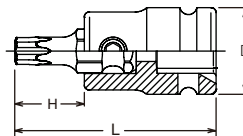

14134X-58/-98 (XZN)

Bit Holder complete with XZN Bit
Klingenhälter, komplett mit XZN Klinge
Porte embouts avec bit XZN

14134X-58/-98 (XZN)	D (mm)	H (mm)	L (mm)	L (mm)	R (mm)	L=58 (g)	L=98 (g)	L=58 (pcs.)	L=98 (pcs.)	Ⓢ
New M 5	25	20.6	58	98	6.0	108	124	10	5	*1
New M 6	25	20.6	58	98	6.2	110	126	10	5	*1
New M 8	25	20.6	58	98	7.4	112	129	10	5	*1
New M10	25	20.6	58	98	9.8	116	144	10	5	*1
New M12	25	20.6	58	98	11.7	120	149	10	5	*1
New M14	25	20.6	58	98	13.5	128	159	10	5	*1



*1 C-Ring=1401C, Pin/O-Ring=1401A/B → P250-251

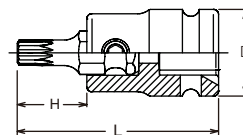

	D ₁ (mm)	D ₂ (mm)	L (mm)	(g)	(pcs.)	
14106	28	30	43	160	10	*1

*1 C-Ring=1402C, Pin/O-Ring=1402A/B → P250-251

14106-SC

 Replacement Screw : M6x8, ●3mm

107-16 (mm)	L (mm)	(g)	(pcs.)
10	40	46	10
12	40	52	10
13	40	56	10
14	40	60	10
16	40	69	10
17	40	73	10
18	40	78	10
19	40	80	10
22	40	97	10

107-16 (inch)	L (mm)	(g)	(pcs.)
New 3/8	40	45	10
1/2	40	56	10
9/16	40	60	10
5/8	40	69	10
3/4	40	80	10

107-16(L100) (mm)	L (mm)	R (mm)	(g)	(pcs.)
New 10	100	13	122	10
New 12	100	15	146	10
New 14	100	-	166	10
New 17	100	-	193	10
New 19	100	-	232	10
New 22	100	-	254	10

107-16 (T)	L (mm)	(g)	(pcs.)
T55	50	57	10
T60	50	64	10
T70	50	73	10

107-16(L100) (T)	L (mm)	R (mm)	(g)	(pcs.)
New T55	100	11.4	108	10
New T60	100	13.4	130	10
New T70	100	15.7	159	10

107-16 (IP)	L (mm)	(g)	(pcs.)
55IP	50	57	10
60IP	50	64	10
70IP	50	73	10

107-16 (XZN)	L (mm)	(g)	(pcs.)
M14	60	83	10
M16	60	93	10
M18	60	103	10

107-16(L100) (XZN)	L (mm)	R (mm)	(g)	(pcs.)
New M14	100	13.4	131	10
New M16	100	15.8	161	10
New M18	100	17.1	177	10

14106 Bit Holder Klingenhalter Porte-embout

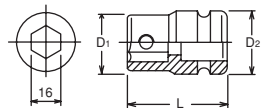

107-16 Bits for Inhex Screws Klingen für Innensechskant-Schrauben Embouts pour vis 6-pans males creux

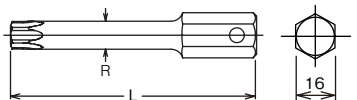
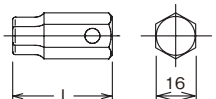

107-16 (T) TORX® Bits TORX® Klingen Embouts, TORX®

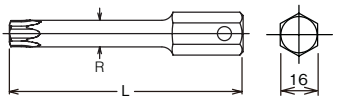
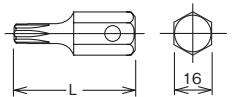

107-16 (IP) TORXPLUS® Bits TORXPLUS® Klingen Embouts TORXPLUS®

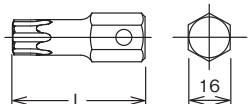

107-16 (XZN) Bits XZN Klingen XZN Embouts de vissage, XZN

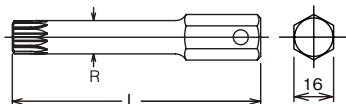
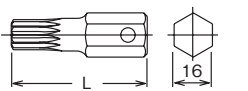

TORX is a registered trademark of Acument Intellectual Properties, LLC.
TORX ist ein registriertes Markenzeichen der Firma Acument Intellectual Properties, LLC.
TORX est une marque déposée de Acument Intellectual Properties, LLC.

TORXplus is a registered trademark of Acument Intellectual Properties, LLC.
TORXplus ist ein registriertes Markenzeichen der Firma Acument Intellectual Properties, LLC.
TORXplus est une marque déposée de Acument Intellectual Properties, LLC.

Impact Sockets Impact Steckschlüssel Douilles Impact

1/2"

Z-SERIES

HAND

TITANIUM

SCREWDRIVERS ACCESSORIES

IMPACT

SLEEVE-DRIVE

PROTECTOR

INDUSTRIAL

AUTOMOTIVE

MOTORCYCLE

CONSTRUCTION

SPARE PART

14139 ○ Bit Holder Klingenhalter Porte-embouts

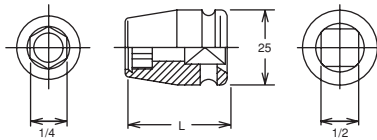

	D ₁ (mm)	D ₂ (mm)	L (mm)	(g)	(pcs.)	⊕
14139-1/4	11	25	35	62	10	*1

*1 C-Ring=1401C, Pin/O-Ring=1401A/B

→ P250-251

For DIN3126 C6.3 Bits
Für DIN3126 C6.3 Bits
Pour DIN3126 C6.3 Embouts

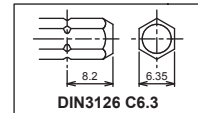

DIN3126 C6.3



14140 ○ Bit Holder Klingenhalter Porte-embouts

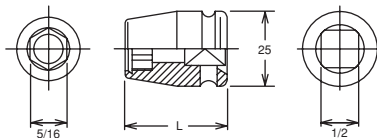

	D ₁ (mm)	D ₂ (mm)	L (mm)	(g)	(pcs.)	⊕
14140-5/16	14	25	35	62	10	*1

*1 C-Ring=1401C, Pin/O-Ring=1401A/B

→ P250-251

For DIN3126 C8 Bits
Für DIN3126 C8 Bits
Pour DIN3126 C8 Embouts

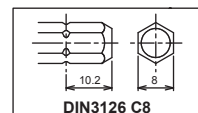

DIN3126 C8



14142-D6.3 ○ Bit Holder (Quick Release) Kingenhalter (Schnellwechselfutter) Porte embouts (mandrin autoserrant)

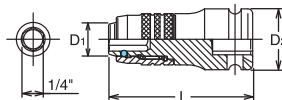

	D ₁ (mm)	D ₂ (mm)	L (mm)	(g)	(pcs.)	⊕
14142-D6.3	16	25	55	97	10	*1

*1 C-Ring=1401C, Pin/O-Ring=1401A/B

→ P250-251

For DIN3126 C6.3 Bits
Für DIN3126 C6.3 Bits
Pour DIN3126 C6.3 Embouts

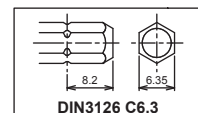

DIN3126 C6.3



14142-F6.3 ○ Bit Holder (Quick Release) Kingenhalter (Schnellwechselfutter) Porte embouts (mandrin autoserrant)

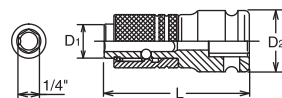

	D ₁ (mm)	D ₂ (mm)	L (mm)	(g)	(pcs.)	⊕
14142-F6.3	16.5	25	55	100	10	*1

*1 C-Ring=1401C, Pin/O-Ring=1401A/B

→ P250-251

For DIN3126 E6.3 Bits
Für DIN3126 E6.3 Bits
Pour DIN3126 E6.3 Embouts

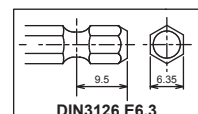

DIN3126 E6.3



Lock & Quick Release

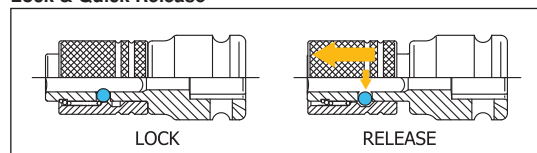

14760-P 14760

Extension Bars
Verlängerungen
Rallonges

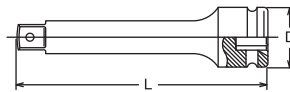

	TYPE	D (mm)	L (mm)	(g)	(pcs.)	⚡	
	14760-50P	Pin	30	50	150	10	*1
New	14760-50	Hole	30	50	150	10	*1
	14760-75P	Pin	30	75	188	10	*1
New	14760-75	Hole	30	75	188	10	*1
	14760-100P	Pin	30	100	240	10	*1
New	14760-100	Hole	30	100	240	10	*1
	14760-125P	Pin	30	125	275	5	*1
New	14760-125	Hole	30	125	275	5	*1
	14760-150P	Pin	30	150	300	5	*1
New	14760-150	Hole	30	150	300	5	*1
	14760-175P	Pin	30	175	358	5	*1
New	14760-175	Hole	30	175	358	5	*1
	14760-200P	Pin	30	200	405	5	*1
New	14760-200	Hole	30	200	405	5	*1
	14760-250P	Pin	30	250	480	1	*1
New	14760-250	Hole	30	250	480	1	*1

*1 C-Ring=1402C, Pin/O-Ring=1402A/B → P250-251

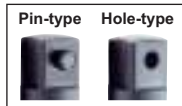

	L (mm)	(g)	(pcs.)	⚡
14444AL	60	128	5	*1

*1 C-Ring=1401C, Pin/O-Ring=1401A/B → P250-251

Lock & Quick Release

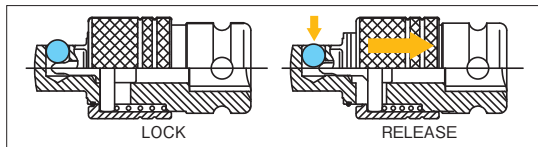

14444AL

Adaptor (Quick Release)
Verbindungsstück (Quick Release)
Adaptateur (Quick Release)

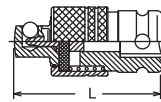

Impact Sockets Impact Steckschlüssel Douilles Impact

1/2"

Z-SERIES
HAND
TITANIUM
SCREWDRIVERS ACCESSORIES
IMPACT
SLEEVE-DRIVE
PROTECTOR
INDUSTRIAL
AUTOMOTIVE
MOTORCYCLE
CONSTRUCTION
SPARE PART

14770-P Universal Joint Gelenk-Einsatz Joint articlé

14770

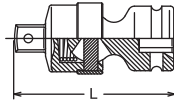

14771-P Universal Joint Gelenk-Einsatz Joint articlé

14771

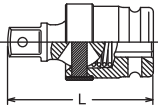

14772-P Universal Double Joint Doppelgelenk-Einsatz Joint articlé double

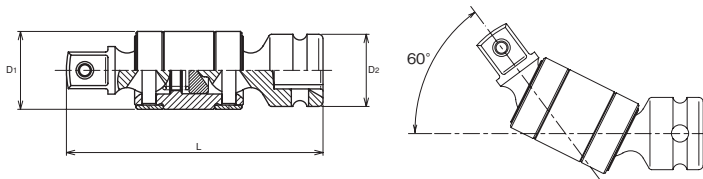

14433A-P Adaptor Verbindungsstück Réducteur

14433A

No Warranty
Keine Garantie
Sans Garantie

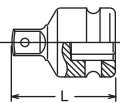

14455A Adaptor Verbindungsstück Augmentateur

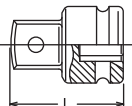

14466A Adaptor Verbindungsstück Augmentateur

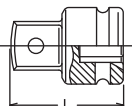

	TYPE	L (mm)	(g)	(pcs.)	
14770-P	Pin	74	210	5	*1
New 14770	Hole	74	210	5	*1
14771-P	Pin	65	198	5	*1
New 14771	Hole	65	198	5	*1

*1 C-Ring=1402C, Pin/O-Ring=1402A/B → P250-251

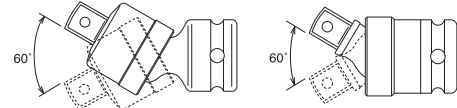
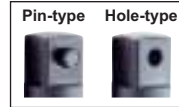

	D1 (mm)	D2 (mm)	L (mm)	(g)	(pcs.)	
14772-P	27	25	90	230	5	*1

*1 C-Ring=1401C, Pin/O-Ring=1401A/B → P250-251



Make sure sockets hold bolts or nuts before operation.

Vergewissern Sie sich vor dem Gebrauch, dass der Steckschlüssel die Schraube sicher umfasst hat.

Avant la manipulation, il est nécessaire de s'assurer que la douille renferme parfaitement la vis.



	TYPE	(sq.)	(sq.)	L (mm)	(g)	(pcs.)	
14433A-P	Pin	1/2"	3/8"	37.5	68	10	*1
New 14433A	Hole	1/2"	3/8"	37.5	68	10	*1

*1 C-Ring=1401C, Pin/O-Ring=1401A/B → P250-251

⚠ Adapting down from bigger square drive to smaller square drive may lead to excessive torque load and possibly cause breakage. Always stay within safe torque of the smaller square drive.

Die mit ⚠ gekennzeichneten Artikel können bei Überbelastung zu Bruch gehen. Aus Gründen Ihrer eigenen Sicherheit sollten die betreffenden Werkzeuge nie ruckartig, sondern nach und nach belastet werden, um Bruch und damit verbundene mögliche Verletzungen zu vermeiden.

Il est possible d'appliquer aux articles marqués ⚠ des couples de serrage susceptibles d'occasionner leur rupture. Pour votre propre sécurité, veuillez toujours appliquer la charge d'une manière uniforme et progressive. Ceci pour éviter ruptures et accidents.

	(sq.)	(sq.)	L (mm)	(g)	(pcs.)	
14455A	1/2"	5/8"	42	135	10	*1





*1 C-Ring=1402C, Pin/O-Ring=1402A/B → P250-251

	(sq.)	(sq.)	L (mm)	(g)	(pcs.)	
14466A	1/2"	3/4"	44	146	10	*1

*1 C-Ring=1402C, Pin/O-Ring=1402A/B → P250-251

New 14209M 10 Pieces Set/⚖️=830g

METAL CASE:W190xH59xT45mm

Bits	Bit Holder
 183H.35 Hex Bits 5, 6, 8, 10	 14134 Bit Holder
 107.16 Hex Bits 12, 14, 17, 19	 14106 Bit Holder







E11.2 × **F11.2** DIN3126

14209M  Socket Sets
Steckschlüssel Sätze
Jeu de clés à douilles



New 14210M 18 Pieces Set/⚖️=1,250g

METAL CASE:W310xH90xT48mm

Bits	Bit Holder
 183H.35 Hex Bits 4, 5, 6, 7, 8, 10, 12, 14	 14134 Bit Holder
 183H.75 Hex Bits 4, 5, 6, 7, 8, 10, 12, 14	 168H-4 (40) Screwdriver







E11.2 × **F11.2** DIN3126

14210M  Socket Sets
Steckschlüssel Sätze
Jeu de clés à douilles



New 14210T 14 Pieces Set/⚖️=1,080g

METAL CASE:W310xH90xT48mm

Bits	Bit Holder
 183T.35 TORX® Bits T30, T40, T45, T50, T55, T60	 14134 Bit Holder
 183T.75 TORX® Bits T30, T40, T45, T50, T55, T60	 168H-4 (40) Screwdriver



E11.2 × **F11.2** DIN3126

14210T  Socket Sets
Steckschlüssel Sätze
Jeu de clés à douilles



New 14210X 14 Pieces Set/⚖️=1,040g

METAL CASE:W310xH90xT48mm

Bits	Bit Holder
 183X.35 XZN Bits M4, M5, M6, M8, M10, M12	 14134 Bit Holder
 183X.75 XZN Bits M4, M5, M6, M8, M10, M12	 168H-4 (40) Screwdriver



E11.2 × **F11.2** DIN3126

14210X  Socket Sets
Steckschlüssel Sätze
Jeu de clés à douilles



Impact Sockets
Impact Steckschlüssel
Douilles Impact **1/2"**

Z-SERIES

HAND

TITANIUM

ACCESSORIES

SCREWDRIVERS

IMPACT

SLEEVE-DRIVE

PROTECTOR

INDUSTRIAL

AUTOMOTIVE

MOTORCYCLE

CONSTRUCTION

SPARE PART

14207M  Socket Set
Steckschlüssel Satz
Jeu de clés à douilles



14207M 10 Pieces Set/⚖️=2,700g

METAL CASE:W310xH90xT48mm

Sockets

 **14300M** 6-pt Deep Sockets
10, 12, 13, 14, 17, 19, 21, 22, 24, 27

14208M  Socket Set
Steckschlüssel Satz
Jeu de clés à douilles



14208M 13 Pieces Set/⚖️=3,500g

METAL CASE:W395xH90xT50mm

Sockets

 **14300M** 6-pt Deep Sockets
10, 12, 13, 14, 15, 16, 17, 18, 19, 21, 22, 24, 27

14241M-00  Socket Set
Steckschlüssel Satz
Jeu de clés à douilles



14241M-00 13 Pieces Set/⚖️=2,000g

METAL CASE:W196xH100xT45mm

Sockets

 **14400M** 6-pt. Sockets
10, 11, 12, 13, 14, 15, 16, 17, 19, 21, 22, 24, 27

14241M-05  Socket Set

14241M-05 13 Pieces Set/⚖️=2,000g

METAL CASE:W196xH100xT45mm

Sockets

 **14405M** 12-pt. Sockets
10, 11, 12, 13, 14, 15, 16, 17, 19, 21, 22, 24, 27

14242M  Socket Set
Steckschlüssel Satz
Jeu de clés à douilles



14242M 12 Pieces Set/⚖️=1,890g

METAL CASE:W310xH90xT48mm

Sockets

 **14400M** 6-pt. Sockets
10, 11, 12, 13, 14, 15, 16, 17, 19, 21, 22, 27

14245M-00  Socket Set
Steckschlüssel Satz
Jeu de clés à douilles







14245M-00 18 Pieces Set/⚖️=2,250g

METAL CASE:W310xH90xT48mm

Sockets

 **14400M** 6-pt. Sockets
10, 12, 13, 14, 16, 17, 18,
19, 21, 22, 24, 27

Accessories

 **14760-125P**
 **14770-P**
 **1401A, 1402A**
 **1401B, 1402B**





14245M-05 18 Pieces Set/⚖️=2,250g

METAL CASE:W310xH90xT48mm

Sockets

 **14405M** 12-pt. Sockets
10, 12, 13, 14, 16, 17, 18,
19, 21, 22, 24, 27

Accessories

 **14760-125P**
 **14770-P**
 **1401A, 1402A**
 **1401B, 1402B**

15400M (mm)	D ₁ (mm)	D ₂ (mm)	ℓ (mm)	L (mm)	(g)	(pcs.)	⚡
14	24	35	10	47.5	220	5	*1
17	27.8	35	12	47.5	225	5	*1
19	30.3	35	13	47.5	225	5	*1
21	32.8	35	15	47.5	225	5	*1
22	34	35	15	47.5	225	5	*1
23	35.4	35	16	47.5	225	5	*1
24	36.5	35	16	50.5	245	5	*1
26	39	35	16	50.5	260	1	*1

*1 Pin/O-Ring=1500A/B → P251

15400M

6-point Sockets
6-kant Steckschlüssel
Douilles 6-pans

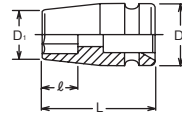

15410M (mm)	D ₁ (mm)	D ₂ (mm)	ℓ (mm)	L (mm)	(g)	(pcs.)	⚡
14	24	35	10	47.5	220	5	*1
17	27.8	35	12	47.5	225	5	*1
19	30.3	35	13	47.5	225	5	*1
21	32.8	35	15	47.5	225	5	*1
22	34	35	15	47.5	225	5	*1
23	35.4	35	16	47.5	225	5	*1
24	36.5	35	16	50.5	245	5	*1
26	39	35	16	50.5	260	5	*1

*1 Pin/O-Ring=1500A/B → P251

15410M

Surface Drive Sockets
Surface Drive Steckschlüssel
Douilles, Surface Drive

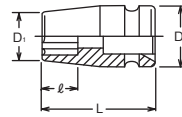

15300M (mm)	D ₁ (mm)	D ₂ (mm)	ℓ (mm)	H (mm)	L (mm)	(g)	(pcs.)	⚡
14	24	35	14	71	90	295	2	*1
17	27.8	35	17	71	90	325	2	*1
19	30.3	35	19	71	90	350	2	*1
21	32.8	35	21	71	90	380	2	*1
22	34	35	22	71	90	390	2	*1

*1 Pin/O-Ring=1500A/B → P251

15300M

6-point Deep Sockets
6-kant-Steckschlüssel, lang
Douilles longues 6-pans

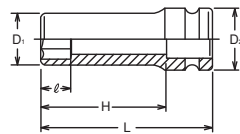

15310M (mm)	D ₁ (mm)	D ₂ (mm)	ℓ (mm)	H (mm)	L (mm)	(g)	(pcs.)	⚡
14	24	35	14	71	90	295	2	*1
17	27.8	35	17	71	90	325	2	*1
19	30.3	35	19	71	90	350	2	*1
21	32.8	35	21	71	90	380	2	*1
22	34	35	22	71	90	390	2	*1

*1 Pin/O-Ring=1500A/B → P251

15310M

Surface Drive Sockets, deep
Surface Drive Steckschlüssel, lang
Douilles longues, Surface Drive

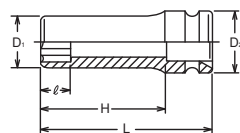

Impact Sockets Impact Steckschlüssel Douilles Impact

5/8"

Z-SERIES
HAND
TITANIUM
SCREWDRIVERS ACCESSORIES
IMPACT
SLEEVE-DRIVE
PROTECTOR
INDUSTRIAL
AUTOMOTIVE
MOTORCYCLE
CONSTRUCTION
SPARE PART

15555AL Adaptor (Quick Release)
Schnellwechsel-Verbindungsstück (Quick Release)
Adaptateur (Quick Release)

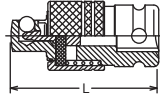

	L (mm)	(g)	(pce.)	
15555AL	70	310	1	*1

*1 Pin/O-Ring=1500A/B → P251

Lock & Quick Release

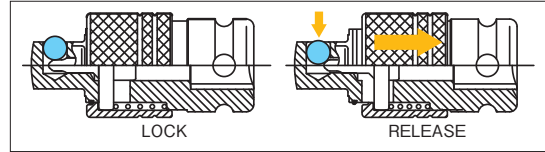

15770 Universal Joint
Gelenk-Einsatz
Joint articlé

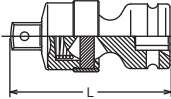

	L (mm)	(g)	(pce.)	
15770	88	420	1	*1

*1 Pin/O-Ring=1500A/B → P251

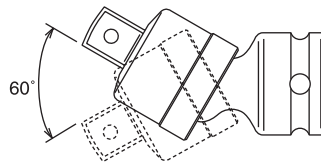

15544A-P Adaptor
Verbindungsstück
Réducteur

No Warranty
Keine Garantie
Sans Garantie

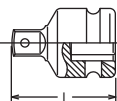

	(sq.)	(sq.)	L (mm)	(g)	(pce.)	
15544A-P	5/8"	1/2"	46	165	1	*1

*1 Pin/O-Ring=1500A/B → P251

⚠ Adapting down from bigger square drive to smaller square drive may lead to excessive torque load and possibly cause breakage. Always stay within safe torque of the smaller square drive.

Die mit **⚠** gekennzeichneten Artikel können bei Überbelastung zu Bruch gehen. Aus Gründen Ihrer eigenen Sicherheit sollten die betreffenden Werkzeuge nie ruckartig, sondern nach und nach belastet werden, um Bruch und damit verbundene mögliche Verletzungen zu vermeiden.

Il est possible d'appliquer aux articles marqués **⚠** des couples de serrage susceptibles d'occasionner leur rupture. Pour votre propre sécurité, veuillez toujours appliquer la charge d'une manière uniforme et progressive. Ceci pour éviter ruptures et accidents.

15566A Adaptor
Verbindungsstück
Augmentateur

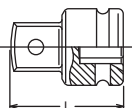

	(sq.)	(sq.)	L (mm)	(g)	(pce.)	
15566A	5/8"	3/4"	48	200	1	*1

*1 Pin/O-Ring=1500A/B → P251

Impact Sockets Impact Steckschlüssel Douilles Impact

3/4"

Z-SERIES
HAND
TITANIUM
ACCESSORIES
SCREWDRIVERS
IMPACT
SLEEVE-DRIVE
PROTECTOR
INDUSTRIAL
AUTOMOTIVE
MOTORCYCLE
CONSTRUCTION
SPARE PART

16401M
16401A



6-point Sockets, Thin Walled
6-kant Steckschlüssel, dünnwandig
Douilles à paroi mince, 6-pans

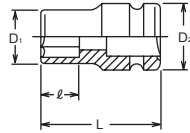

16401A (inch)	D ₁ (mm)	D ₂ (mm)	ℓ (mm)	L (mm)	(g)	(pcs.)	⚡
11/16	28	43	12	50	300	5	*1
3/4	30.5	43	13	50	300	5	*1
13/16	33	43	15	50	305	5	*1
7/8	34.3	43	15	50	310	5	*1
15/16	36.8	43	16	50	325	5	*1
1	38	43	16	50	326	5	*1
1. 1/16	40.5	43	16	50	340	5	*1
1. 1/8	43	43	18	53	355	5	*1
1. 3/16	44.3	43	18	53	365	5	*1
1. 1/4	46.8	43	19	53	385	5	*1
1. 5/16	49.3	30	20	55	437	5	*1
1. 3/8	50.5	43	20	55	430	5	*1
1. 7/16	53	43	20	55	460	2	*1
1. 1/2	54.3	43	20	57	472	2	*1
1. 9/16	56.8	43	20	57	525	2	*1
1. 5/8	58	43	22	57	555	2	*1
1.13/16	64.3	43	23	62	710	2	*1
New 1. 7/8	66.8	53	23	62	868	2	*2

*1 C-Ring=1600C, Pin/O-Ring=1601A/B → P250-251

16401M (mm)	D ₁ (mm)	D ₂ (mm)	ℓ (mm)	L (mm)	(g)	(pcs.)	⚡
17	28	43	12	50	300	5	*1
18	29.3	43	13	50	300	5	*1
19	30.5	43	13	50	300	5	*1
20	31.8	43	14	50	302	5	*1
21	33	43	15	50	305	5	*1
22	34.3	43	15	50	310	5	*1
23	35.5	43	16	50	315	5	*1
24	36.8	43	16	50	325	5	*1
25	38	43	16	50	326	5	*1
26	39.3	43	16	50	330	5	*1
27	40.5	43	16	50	340	5	*1
28	41.8	43	16	50	345	5	*1
29	43	43	18	53	355	5	*1
30	44.3	43	18	53	365	5	*1
31	45.5	43	18	53	375	5	*1
32	46.8	43	19	53	385	5	*1
33	48	43	20	55	395	5	*1
34	49.3	43	20	55	420	5	*1
35	50.5	43	20	55	430	5	*1
36	51.8	43	20	55	440	5	*1
37	53	43	20	55	460	2	*1
38	54.3	43	20	57	472	2	*1
40	56.8	43	20	57	525	2	*1
41	58	43	22	57	555	2	*1
42	59.3	43	22	57	565	2	*1
New 43	60.5	43	23	62	662	2	*1
New 44	61.8	43	23	62	670	2	*1
New 45	63	43	23	62	700	2	*1
46	64.3	43	23	62	710	2	*1

*1 C-Ring=1600C, Pin/O-Ring=1601A/B → P250-251

16410M



Surface Drive Sockets
Surface Drive Steckschlüssel
Douilles, Surface Drive

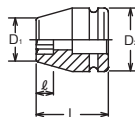

16410M (mm)	D ₁ (mm)	D ₂ (mm)	ℓ (mm)	L (mm)	(g)	(pcs.)	⚡
New 16	28.8	44	11	50	367	5	*1
New 17	30	44	12	50	355	5	*1
New 18	31.3	44	13	50	372	5	*1
New 19	32.5	44	13	50	360	5	*1
New 21	35	44	15	50	374	5	*1
New 22	36.3	44	15	50	373	5	*1
New 24	38.8	44	16	50	370	5	*1
New 27	42.5	44	16	50	375	5	*1
New 30	46.3	44	18	53	410	5	*1
New 32	48.8	44	19	53	428	5	*1
New 33	50	44	20	55	470	5	*1
New 36	53.8	44	20	55	498	5	*1

*1 C-Ring=1600C, Pin/O-Ring=1601A/B → P250-251

3/4"

Impact Sockets
Impact Steckschlüssel
Douilles Impact

Z-SERIES
HAND
TITANIUM
ACCESSORIES
SCREWDRIVERS
IMPACT
SLEEVE-DRIVE
PROTECTOR
INDUSTRIAL
AUTOMOTIVE
MOTORCYCLE
CONSTRUCTION
SPARE PART

16425 (E)	D ₁ (mm)	D ₂ (mm)	ℓ (mm)	L (mm)	(g)	(pcs.)	⚡
E18	26.3	44	13	50	355	5	*1
E20	28.8	44	14.4	50	370	5	*1
E22	31.3	44	15.5	50	390	5	*1
E24	32.5	44	17	50	390	5	*1
E26	35	44	18.8	60	460	5	*1
E28	36.3	44	25.2	60	465	5	*1
E30	38.8	44	25.2	60	480	5	*1
E32	41.3	44	25.2	60	480	5	*1

*1 C-Ring=1600C, Pin/O-Ring=1601A/B → P250-251

16425 TORX® Sockets
TORX® Steckschlüssel
Douilles TORX®

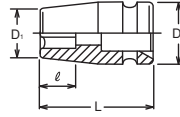

TORX® (E)

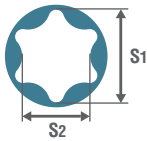

E	E4	E5	E6	E7	E8	E10	E11	E12	E14	E16	E18	E20	E22	E24	E26	E28
S ₁ (ref. mm)	3.7	4.6	5.6	6.1	7.4	9.3	9.9	11.0	12.8	14.6	16.5	18.3	20.1	22.0	23.7	25.5
S ₂ (ref. mm)	2.7	3.3	4.0	4.3	5.3	6.8	7.1	7.9	9.2	10.5	11.9	13.2	14.8	15.7	17.5	18.3

16425 (EPL)	D ₁ (mm)	D ₂ (mm)	ℓ (mm)	L (mm)	(g)	(pcs.)	⚡
24EPL	32.5	44	12.2	55	427	5	*1
32EPL	40	44	16.1	62	488	2	*1

*1 C-Ring=1600C, Pin/O-Ring=1601A/B → P250-251

16425-EPL TORXPLUS® Sockets
TORXPLUS® Steckschlüssel
Douilles TORXPLUS®

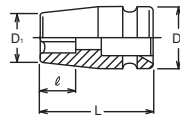

TORXplus®

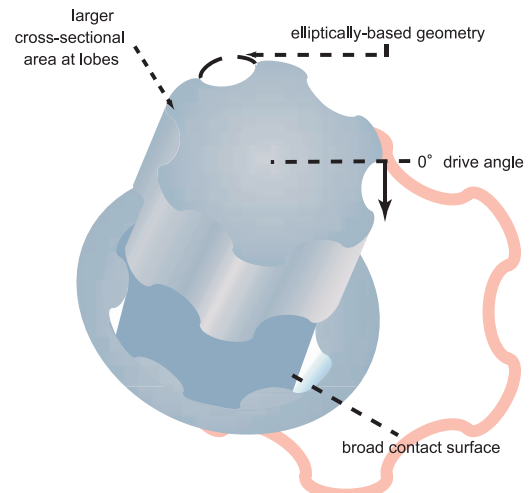
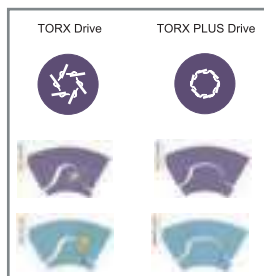
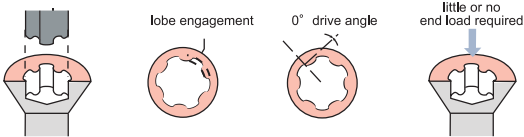

TORX® is a registered trademark of Acument Intellectual Properties, LLC.
 TORX® ist ein registriertes Markenzeichen der Firma Acument Intellectual Properties, LLC.
 TORX® est une marque déposée de Acument Intellectual Properties, LLC.
 TORXplus® is a registered trademark of Acument Intellectual Properties, LLC.
 TORXplus® ist ein registriertes Markenzeichen der Firma Acument Intellectual Properties, LLC.
 TORXplus® est une marque déposée de Acument Intellectual Properties, LLC.

Impact Sockets

Impact Steckschlüssel 3/4"

Douilles Impact

Z-SERIES
HAND
TITANIUM
SCREWDRIVERS ACCESSORIES
IMPACT
SLEEVE-DRIVE
PROTECTOR
INDUSTRIAL
AUTOMOTIVE
MOTORCYCLE
CONSTRUCTION
SPARE PART

16301X  6-point Semi-Deep Sockets, Thin Walled
6-kant Steckschlüssel mittel lang, dünnwandig
Douilles à paroi mince semi-longues, 6-pans

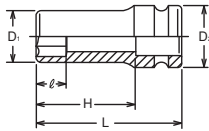

16301X (mm)	D ₁ (mm)	D ₂ (mm)	ℓ (mm)	H (mm)	L (mm)	⚖️ (g)	📦 (pcs.)	⚡
17	28	43	17	49	75	370	2	*1
18	29.3	43	18	49	75	380	2	*1
19	30.5	43	19	49	75	393	2	*1
20	31.8	43	20	49	75	400	2	*1
21	33	43	21	49	75	408	2	*1
22	34.3	43	22	49	75	418	2	*1
23	35.5	43	23	49	75	425	2	*1
24	36.8	43	24	49	75	435	2	*1
25	38	43	25	49	75	449	2	*1
26	39.3	43	26	49	75	455	2	*1
27	40.5	43	27	48	75	464	2	*1
28	41.8	43	28	48	75	479	2	*1
29	43	43	29	48	75	489	2	*1
30	44.3	43	30	48	75	506	2	*1
31	45.5	43	31	47	75	518	2	*1
32	46.8	43	32	47	75	535	2	*1
33	48	43	33	47	75	550	2	*1
35	50.5	43	35	46	75	585	2	*1
36	51.8	43	36	46	75	603	2	*1
37	53	43	37	46	75	645	2	*1
38	54.3	43	38	50	80	691	2	*1
40	56.8	43	38	50	80	725	2	*1
41	58	43	38	49	80	755	2	*1
46	64.3	43	38	48	80	808	2	*1

*1 C-Ring=1600C, Pin/O-Ring=1601A/B → P250-251

16300M / 16300A  6-point Sockets, deep
6-kant Steckschlüssel, lang
Douilles longues, 6-pans

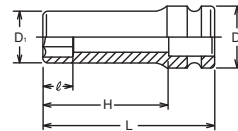

16300M (mm)	D ₁ (mm)	D ₂ (mm)	ℓ (mm)	H (mm)	L (mm)	⚖️ (g)	📦 (pcs.)	⚡
New 14	26.3	44	14	74	100	497	2	*1
New 16	28.8	44	16	74	100	524	2	*1
17	30	44	17	74	100	544	2	*1
18	31.3	44	18	74	100	642	2	*1
19	32.5	44	19	74	100	655	2	*1
20	33.8	44	20	74	100	680	2	*1
21	35	44	21	74	100	700	2	*1
22	36.3	44	22	74	100	700	2	*1
23	37.5	44	23	74	100	720	2	*1
24	38.8	44	24	74	100	705	2	*1
25	40	44	25	74	100	715	2	*1
26	41.3	44	26	74	100	710	2	*1
27	42.5	44	27	73	100	710	2	*1
28	43.8	44	28	73	100	800	2	*1
29	45	44	29	73	100	835	2	*1
30	46.3	44	30	73	100	840	2	*1
31	47.5	44	31	72	100	815	2	*1
32	48.8	44	32	72	100	875	2	*1
33	50	44	33	72	100	920	2	*1
34	51.3	44	34	72	100	950	2	*1
35	52.5	44	35	71	100	980	2	*1
36	53.8	44	36	71	100	960	2	*1
37	55	44	37	71	100	970	2	*1
38	56.3	44	38	70	100	990	2	*1
40	58.8	44	38	70	100	1060	2	*1
41	60	44	38	69	100	1120	2	*1
42	61.3	44	38	69	100	1153	2	*1
43	62.5	44	38	69	100	1200	2	*1
46	66.3	44	38	68	100	1305	2	*1
New 48	68.8	54	38	68	100	1480	2	*2
50	71.3	54	61	—	100	1469	2	*2
55	77.5	54	59	—	100	1620	2	*2
New 60	83.8	54	56	—	100	1835	2	*2



*1 C-Ring=1600C, Pin/O-Ring=1601A/B
*2 C-Ring=1801C, Pin/O-Ring=1602A/B → P250-251

16300A (inch)	D ₁ (mm)	D ₂ (mm)	ℓ (mm)	H (mm)	L (mm)	⚖️ (g)	📦 (pcs.)	⚡
3/4	32.5	44	19	74	100	655	2	*1
13/16	35	44	21	74	100	700	2	*1
7/8	36.3	44	22	74	100	700	2	*1
15/16	38.8	44	24	74	100	705	2	*1
1	40	44	25	74	100	715	2	*1
1. 1/16	42.5	44	27	73	100	765	2	*1
1. 1/8	45	44	29	73	100	835	2	*1
1. 3/16	46.3	44	30	73	100	840	2	*1
1. 1/4	48.8	44	32	72	100	875	2	*1
1. 5/16	51.3	44	34	72	100	950	2	*1
1. 3/8	52.5	44	35	71	100	980	2	*1
1. 7/16	55	44	37	71	100	970	2	*1
1. 1/2	56.3	44	38	70	100	990	2	*1
1. 9/16	58.8	44	38	70	100	1060	2	*1
1. 5/8	60	44	38	69	100	1120	2	*1
1.11/16	62.5	44	38	69	100	1200	2	*1
1. 3/4	65	44	38	68	100	1284	2	*1
1.13/16	66.3	44	38	68	100	1305	2	*1
1. 7/8	68.8	54	38	67	100	1561	2	*2
2	72.5	54	60	—	100	1516	2	*2

*1 C-Ring=1600C, Pin/O-Ring=1601A/B
*2 C-Ring=1801C, Pin/O-Ring=1602A/B → P250-251

3/4"

Impact Sockets
Impact Steckschlüssel
Douilles Impact

16301M  6-point Deep Sockets, Thin Walled
16301A  6-kant Steckschlüssel, dünnwandig
Douilles à paroi mince longues, 6-pans

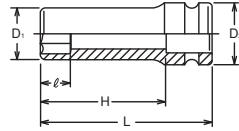

16301M (mm)	D ₁ (mm)	D ₂ (mm)	ℓ (mm)	H (mm)	L (mm)	(g)	(pcs.)	⚡
New 16	26.8	43	16	74	100	435	2	*1
17	28	43	17	74	100	470	2	*1
18	29.3	43	18	74	100	475	2	*1
19	30.5	43	19	74	100	480	2	*1
20	31.8	43	20	74	100	491	2	*1
21	33	43	21	74	100	505	2	*1
22	34.3	43	22	74	100	528	2	*1
23	35.5	43	23	74	100	542	2	*1
24	36.8	43	24	74	100	560	2	*1
25	38	43	25	74	100	581	2	*1
26	39.3	43	26	74	100	600	2	*1
27	40.5	43	27	73	100	610	2	*1
28	41.8	43	28	73	100	639	2	*1
29	43	43	29	73	100	650	2	*1
30	44.3	43	30	73	100	670	2	*1
31	45.5	43	31	72	100	690	2	*1
32	46.8	43	32	72	100	715	2	*1
33	48	43	33	72	100	750	2	*1
34	49.3	43	34	72	100	772	2	*1
35	50.5	43	35	71	100	785	2	*1
36	51.8	43	36	71	100	830	2	*1
37	53	43	37	71	100	850	2	*1
38	54.3	43	38	70	100	885	2	*1
40	56.8	43	38	70	100	925	2	*1
41	58	43	38	69	100	970	2	*1
42	59.3	43	38	69	100	990	2	*1
46	64.3	43	38	68	100	1150	2	*1
New 50	69.2	53	62	-	100	1328	2	*1

*1 C-Ring=1600C, Pin/O-Ring=1601A/B → P250-251

16301A (inch)	D ₁ (mm)	D ₂ (mm)	ℓ (mm)	H (mm)	L (mm)	(g)	(pcs.)	⚡
11/16	28	43	17	74	100	470	2	*1
3/4	30.5	43	19	74	100	480	2	*1
13/16	33	43	21	74	100	505	2	*1
7/8	34.3	43	22	74	100	528	2	*1
15/16	36.8	43	24	74	100	560	2	*1
1	38	43	25	74	100	581	2	*1
1. 1/16	40.5	43	27	73	100	610	2	*1
1. 1/8	43	43	29	73	100	650	2	*1
1. 3/16	44.3	43	30	73	100	670	2	*1
1. 1/4	46.8	43	32	72	100	715	2	*1
New 1. 5/16	49.3	43	34	72	100	790	2	*1
1. 3/8	50.5	43	35	71	100	785	2	*1
1. 7/16	53	43	37	71	100	850	2	*1
1. 1/2	54.3	43	38	70	100	885	2	*1
1. 9/16	56.8	43	38	70	100	925	2	*1
1. 5/8	58	43	38	69	100	970	2	*1
1.13/16	64.3	43	38	68	100	1150	2	*1

*1 C-Ring=1600C, Pin/O-Ring=1601A/B → P250-251

16305M (mm)	D ₁ (mm)	D ₂ (mm)	ℓ (mm)	H (mm)	L (mm)	(g)	(pcs.)	⚡
14	26.3	44	14	74	100	500	2	*1
New 16	28.8	44	16	74	100	522	2	*1
17	30	44	17	74	100	544	2	*1
18	31.3	44	18	74	100	600	2	*1
19	32.5	44	19	74	100	655	2	*1
21	35	44	21	74	100	700	2	*1
22	36.3	44	22	74	100	700	2	*1
23	37.5	44	23	74	100	720	2	*1
24	38.8	44	24	74	100	715	2	*1
26	41.3	44	26	74	100	760	2	*1
27	42.5	44	27	73	100	765	2	*1
28	43.8	44	28	73	100	800	2	*1
29	45	44	29	73	100	835	2	*1
30	46.3	44	30	73	100	840	2	*1
32	48.8	44	32	72	100	875	2	*1
New 33	50	44	33	72	100	920	2	*1
New 34	51.3	44	34	72	100	950	2	*1
35	52.5	44	35	71	100	980	2	*1
36	53.8	44	36	71	100	960	2	*1
38	56.3	44	38	70	100	990	2	*1
41	60	44	38	69	100	1120	2	*1
46	66.3	44	38	68	100	1305	2	*1
New 50	71.3	54	61	-	100	1469	2	*2

*1 C-Ring=1600C, Pin/O-Ring=1601A/B → P250-251

16305M  12-point Sockets, deep
12-kant Steckschlüssel, lang
Douilles longues, 12-pans

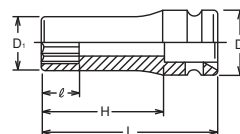



Z-SERIES
HAND
TITANIUM
ACCESSORIES
SCREWDRIVERS
IMPACT
SLEEVE-DRIVE
PROTECTOR
INDUSTRIAL
AUTOMOTIVE
MOTORCYCLE
CONSTRUCTION
SPARE PART

Impact Sockets Impact Steckschlüssel 3/4"

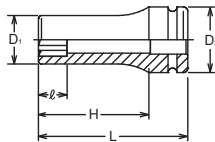
16310M Surface Drive Sockets, deep Surface Drive Steckschlüssel, lang Douilles longues, Surface Drive



16310M	D ₁	D ₂	ℓ	H	L			
(mm)	(mm)	(mm)	(mm)	(mm)	(mm)	(g)	(pcs.)	
New 16	28.8	44	16	74	100	524	2	*1
New 17	30	44	17	74	100	544	2	*1
New 18	31.3	44	18	74	100	642	2	*1
New 19	32.5	44	19	74	100	655	2	*1
New 21	35	44	21	74	100	700	2	*1
New 22	36.3	44	22	74	100	700	2	*1
New 24	38.8	44	24	74	100	705	2	*1
New 27	42.5	44	27	73	100	710	2	*1
New 30	46.3	44	30	73	100	840	2	*1
New 32	48.8	44	32	72	100	875	2	*1
New 33	50	44	33	72	100	920	2	*1
New 36	53.8	44	34	71	100	960	2	*1

*1 C-Ring=1600C, Pin/O-Ring=1601A/B → P250-251

SURFACE DRIVE







Surface drive sockets are designed to retain contact with the flat sides of the nut in order to transmit higher torque and reduce nut wear. These sockets are ideal for using on polished nuts, aluminum nuts and nuts with worn out points.

Das Profil unserer Surface-Drive Steckschlüssel greift die Schraube an deren Flächen. Dies sichert eine höhere Kraftübertragung und verhindert ein Durchrutschen des Steckschlüssels. Diese Steckschlüssel eignen sich besonders für polierte Schrauben, Aluminium Schrauben und Schrauben bei denen die Ecken bereits abgerundet sind.

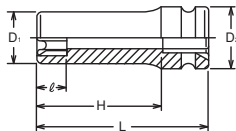
Notre profil Surface Drive assure le contact entre la douille et les plats de l'écrou. Ceci réduit l'usure et permet la transmission d'un couple plus élevé. C'est une solution idéale pour les écrous polies, celles en aluminium ou arrondies.

16325 TORX® Deep Sockets TORX® Steckschlüssel, lang Douilles longues TORX®



16325	D ₁	D ₂	ℓ	H	L			
(E)	(mm)	(mm)	(mm)	(mm)	(mm)	(g)	(pcs.)	
E18	26.3	44	13	74	100	520	2	*1
E20	28.8	44	14.4	74	100	560	2	*1
E22	31.3	44	15.5	74	100	600	2	*1
E24	32.5	44	17	74	100	630	2	*1
New E26	35.0	44	18.8	74	100	660	2	*1
New E28	36.3	44	25.2	74	100	670	2	*1
New E30	38.8	44	25.2	75	100	730	2	*1
New E32	41.3	44	25.2	75	100	777	2	*1

*1 C-Ring=1600C, Pin/O-Ring=1601A/B → P250-251

TORX® (E)

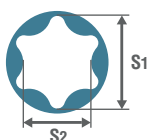

E	E4	E5	E6	E7	E8	E10	E11	E12	E14	E16	E18	E20	E22	E24	E26	E28
S ₁ (ref. mm)	3.7	4.6	5.6	6.1	7.4	9.3	9.9	11.0	12.8	14.6	16.5	18.3	20.1	22.0	23.7	25.5
S ₂ (ref. mm)	2.7	3.3	4.0	4.3	5.3	6.8	7.1	7.9	9.2	10.5	11.9	13.2	14.8	15.7	17.5	18.3

	D ₁ (mm)	D ₂ (mm)	ℓ (mm)	L (mm)	(g)	(pcs.)	⚡
16106	32	44	16	52	370	2	*1

*1 C-Ring=1600C, Pin/O-Ring=1601A/B → P250-251

16106-SC

Replacement Screw : M6x10, ⌀3mm

	107-16 (mm)	L (mm)	L (mm)	L=40 (g)	L=100 (g)	(pcs.)
New	10	40	100	46	122	10
	12	40	100	52	146	10
	13	40	-	56	-	10
New	14	40	100	60	166	10
	16	40	-	69	-	10
New	17	40	100	73	193	10
	18	40	-	78	-	10
New	19	40	100	80	232	10
New	22	40	100	97	254	10

	107-16 (inch)	L (mm)	(g)	(pcs.)
New	3/8	40	45	10
	1/2	40	56	10
	9/16	40	60	10
	5/8	40	69	10
	3/4	40	80	10

	107-16 (T)	L (mm)	L (mm)	L=50 (g)	L=100 (g)	(pcs.)
New	T55	50	100	57	108	10
New	T60	50	100	64	130	10
New	T70	50	100	73	159	10

	107-16 (IP)	L (mm)	(g)	(pcs.)
	55IP	50	57	10
	60IP	50	64	10
	70IP	50	73	10

	107-16 (XZN)	L (mm)	L (mm)	L=60 (g)	L=100 (g)	(pcs.)
New	M14	60	100	83	131	10
New	M16	60	100	93	161	10
New	M18	60	100	103	177	10

16106-16 (mm)	D (mm)	H (mm)	L (mm)	(g)	(pcs.)	⚡
10	44	24	76	416	2	*1
12	44	24	76	422	2	*1
13	44	24	76	426	2	*1
14	44	24	76	430	2	*1
16	44	24	76	439	2	*1
17	44	24	76	443	2	*1
18	44	24	76	448	2	*1
19	44	24	76	450	2	*1
22	44	24	76	473	2	*1

16106-16 (inch)	D (mm)	H (mm)	L (mm)	(g)	(pcs.)	⚡
1/2	44	24	76	426	2	*1
9/16	44	24	76	430	2	*1
5/8	44	24	76	439	2	*1
3/4	44	24	76	450	2	*1

*1 C-Ring=1600C, Pin/O-Ring=1601A/B → P250-251

TORX is a registered trademark of Acument Intellectual Properties, LLC.
TORX ist ein registriertes Markenzeichen der Firma Acument Intellectual Properties, LLC.
TORX est une marque déposée de Acument Intellectual Properties, LLC.

TORXplus is a registered trademark of Acument Intellectual Properties, LLC.
TORXplus ist ein registriertes Markenzeichen der Firma Acument Intellectual Properties, LLC.
TORXplus est une marque déposée de Acument Intellectual Properties, LLC.

16106 ○ Bit Holder Klingenhalter Porte-embout

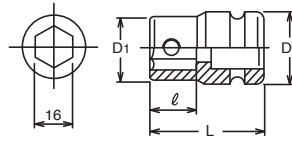

107-16 ● Bits for Inhex Screws Klingen für Innensechskant-Schrauben Embout pour vis 6-pans males creux

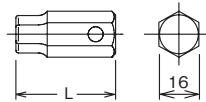

107-16 (T) ● TORX® Bits TORX® Klingen Embout, TORX®

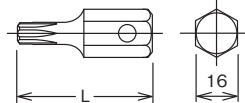

107-16 (IP) ● TORXPLUS® Bits TORXPLUS® Klingen Embout TORXPLUS®

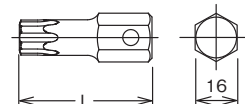

107-16 (XZN) ● Bits XZN Klingen XZN Embout de vissage, XZN

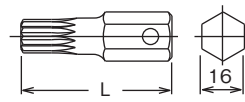

16106-16 ● Bit Holder complete with Bit, Inhex Klingenhalter komplett mit Klinge, Innensechskant Porte embouts avec bit 6-pans creux

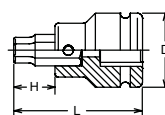

Impact Sockets Impact Steckschlüssel Douilles Impact

3/4"

Z-SERIES
HAND
TITANIUM
SCREWDRIVERS
ACCESSORIES
IMPACT
SLEEVE-DRIVE
PROTECTOR
INDUSTRIAL
AUTOMOTIVE
MOTORCYCLE
CONSTRUCTION
SPARE PART

16107-22

Bit Holder complete with Bit
Klingenhalter, komplett mit Klinge
Porte embouts avec bit

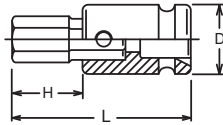

16107-22 (mm)	D (mm)	H (mm)	L (mm)	(g)	(pcs.)	
19	44	28	88	670	2	*1
22	44	28	88	692	2	*1
24	44	28	88	706	2	*1
27	44	28	88	730	2	*1
30	44	28	88	757	2	*1
32	44	28	93	783	2	*1

*1 C-Ring=1600C, Pin/O-Ring=1601A/B → P250-251

16107

Bit Holder
Klingenhalter
Porte embouts

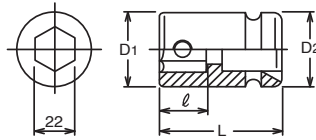

	D ₁ (mm)	D ₂ (mm)	l (mm)	L (mm)	(g)	(pcs.)	
16107	44	44	22	60	530	2	*1

*1 C-Ring=1600C, Pin/O-Ring=1601A/B → P250-251

16107-SC

Replacement Screw : M8x14, ●4mm

107-22

Bits for Inhex Screws
Klingen für Innensechskant-Schrauben
Embouts pour vis 6-pans males creux

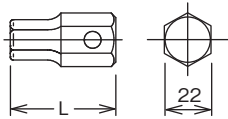

107-22 (mm)	L (mm)	(g)	(pcs.)
17	50	120	10
19	50	140	10
22	50	162	10
24	50	176	10
27	50	200	10
30	50	227	10
32	55	243	10

107-22 (inch)	L (mm)	(g)	(pcs.)
5/8	50	120	10
3/4	50	140	10
7/8	50	162	10
1	50	190	10
1. 1/4	55	243	10

107-22 (T)

TORX® Bits
TORX® Klingen
Embouts, TORX®

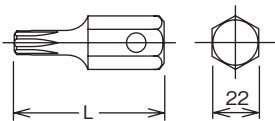

107-22 (T)	L (mm)	(g)	(pcs.)
New T 70	60	125	10
T 80	60	141	10
T 90	60	155	10
T100	60	170	10

16760-150/-175/-200/-250/-330

Extension Bars
Verlängerungen
Rallonges

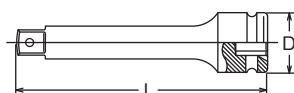

16760	D (mm)	L (mm)	(g)	(pce.)	
150	44	150	775	1	*1
175	44	175	870	1	*1
200	44	200	955	1	*1
250	44	250	1150	1	*1
330	44	330	1460	1	*1

*1 C-Ring=1600C, Pin/O-Ring=1601A/B → P250-251

	L (mm)	(g)	(pcs.)	⚡
16666AL	75	660	2	*1

*1 C-Ring=1600C, Pin/O-Ring=1601A/B → P250-251

Lock & Quick Release

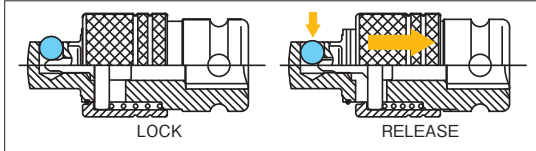

	L (mm)	(g)	(pce.)	⚡
16770	106	790	1	*1
16771	95	720	1	*1

*1 C-Ring=1600C, Pin/O-Ring=1601A/B → P250-251

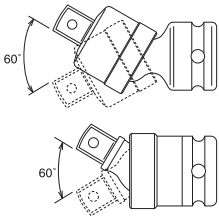

	TYPE	(sq.)	(sq.)	L (mm)	(g)	(pcs.)	⚡
16644A-P	Pin	3/4"	1/2"	54	310	5	*1
16644A	Hole	3/4"	1/2"	54	310	5	*1

	(sq.)	(sq.)	L (mm)	(g)	(pcs.)	⚡
16655A	3/4"	5/8"	55.5	336	5	*1

*1 C-Ring=1600C, Pin/O-Ring=1601A/B → P250-251

⚠ Adapting down from bigger square drive to smaller square drive may lead to excessive torque load and possibly cause breakage. Always stay within safe torque of the smaller square drive.

Die mit **⚠** gekennzeichneten Artikel können bei Überbelastung zu Bruch gehen. Aus Gründen Ihrer eigenen Sicherheit sollten die betreffenden Werkzeuge nie ruckartig, sondern nach und nach belastet werden, um Bruch und damit verbundene mögliche Verletzungen zu vermeiden.

Il est possible d'appliquer aux articles marqués **⚠** des couples de serrage susceptibles d'occasionner leur rupture. Pour votre propre sécurité, veuillez toujours appliquer la charge d'une manière uniforme et progressive. Ceci pour éviter ruptures et accidents.

	(sq.)	(sq.)	L (mm)	(g)	(pce.)	⚡
16688A	3/4"	1"	62	435	1	*1
16688A-250	3/4"	1"	250	1400	1	*1
16688A-330	3/4"	1"	330	1880	1	*1

*1 C-Ring=1600C, Pin/O-Ring=1601A/B → P250-251

16666AL

Adaptor (Quick Release)
Verbindungsstück (Quick Release)
Adaptateur (Quick Release)

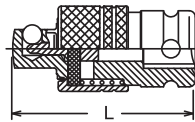

16770

Universal Joint
Gelenk-Einsatz
Joint articlé

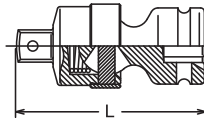

16771

Universal Joint
Gelenk-Einsatz
Joint articlé

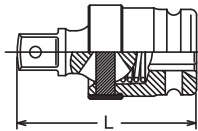

16644A-P 16644A 16655A

Adaptors
Verbindungsstücke
Réducteurs

No Warranty **⚠**
Keine Garantie
Sans Garantie

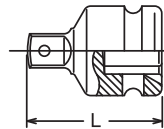

16688A

Adaptor
Verbindungsstück
Augmentateur

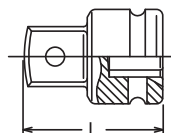

16688A-250/-330

Adaptors
Verbindungsstücke
Réducteurs



Impact Sockets
Impact Steckschlüssel
Douilles Impact

3/4"

Z-SERIES
HAND
TITANIUM
ACCESSORIES
SCREWDRIVERS
IMPACT
SLEEVE-DRIVE
PROTECTOR
INDUSTRIAL
AUTOMOTIVE
MOTORCYCLE
CONSTRUCTION
SPARE PART

16201M-00 / 16201A-00

Socket Sets
Steckschlüssel Sätze
Jeux de clés à douilles



16201A-00	11 Pieces Set/△=6,000g
METAL CASE:W320×H110×T70mm	
Sockets	
16400A 6-pt. Sockets	
3/4, 7/8, 15/16, 1, 1.1/16, 1.1/8, 1.1/4, 1.5/16, 1.3/8, 1.7/16, 1.1/2	

16201M-00	13 Pieces Set/△=6,800g
METAL CASE:W320×H110×T70mm	
Sockets	
16400M 6-pt. Sockets	
19, 21, 22, 23, 24, 26, 27, 30, 32, 33, 36, 38, 41	

16201M-01 / 16201A-01

Socket Sets
Steckschlüssel Sätze
Jeux de clés à douilles





16201A-01	11 Pieces Set/△=5,400g
METAL CASE:W320×H110×T70mm	
Sockets	
16401A 6-pt. Sockets, Thin-walled	
3/4, 7/8, 15/16, 1, 1.1/16, 1.1/8, 1.1/4, 1.5/16, 1.3/8, 1.7/16, 1.1/2	

16201M-01	13 Pieces Set/△=6,000g
METAL CASE:W320×H110×T70mm	
Sockets	
16401M 6-pt. Sockets, Thin-walled	
19, 21, 22, 23, 24, 26, 27, 30, 32, 33, 36, 38, 41	

16245M

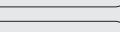

Socket Sets
Steckschlüssel Sätze
Jeux de clés à douilles



16245M	17 Pieces Set/△=12,000g
METAL CASE:W590×H127×T72mm	
Sockets	
16400M 6-pt. Sockets	
19, 21, 22, 24, 27, 29, 30, 32, 33, 35, 36, 38, 41, 46, 50	
Accessories	
	16760-175
	16760-330

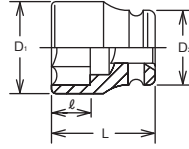

18400M / 18400A 6-point Sockets 6-kant Steckschlüssel Douilles 6-pans



18400A (inch)	D ₁ (mm)	D ₂ (mm)	ℓ (mm)	L (mm)			
	(mm)	(mm)	(mm)	(mm)	(g)	(pcs.)	
11/16	32.8	54	12	57	579	2	*1
3/4	35.3	54	13	57	590	2	*1
13/16	37.8	54	15	57	605	2	*1
7/8	39	54	15	57	620	2	*1
15/16	41.5	54	16	57	627	2	*1
1	42.8	54	16	57	620	2	*1
1. 1/16	45.3	54	16	57	627	2	*1
1. 1/8	47.8	54	18	57	657	2	*1
1. 3/16	49	54	21	62	657	2	*1
1. 1/4	51.5	54	21	62	685	2	*1
1. 5/16	54	54	21	62	690	2	*1
1. 3/8	55.3	54	21	62	710	2	*1
1. 7/16	57.8	54	21	62	735	2	*1
1. 1/2	59	54	25	66	720	2	*1
1. 9/16	61.5	54	25	66	850	2	*1
1. 5/8	62.8	54	25	66	850	2	*1
1.11/16	65.3	54	27	68	977	2	*1
1. 3/4	67.8	54	27	68	963	2	*1
1.13/16	69	54	29	70	1010	2	*1
1. 7/8	71.5	54	35	70	990	2	*1
1.15/16	72.8	54	35	70	1000	2	*1
2	75.3	54	35	70	1060	2	*1
2. 1/16	76.5	54	40	75	1185	2	*1
2. 1/8	79	54	40	75	1252	2	*1
2. 3/16	80.3	54	39	75	1260	2	*1
2. 1/4	82.8	54	39	75	1337	2	*1
2. 5/16	84	54	39	75	1340	2	*1
2. 3/8	86.5	54	39	75	1400	2	*1
2. 7/16	89	54	38	75	1410	2	*1
2. 1/2	91.5	54	38	75	1498	2	*1
2. 9/16	92.8	54	38	75	1630	2	*1
2. 5/8	95.3	54	38	75	1580	2	*1
2.11/16	96.5	54	37	75	1583	1	*1
2. 3/4	99	54	37	75	1625	1	*1
2.13/16	101.5	86	37	80	2705	1	*2
2. 7/8	102.8	86	38	80	2629	1	*2
2.15/16	105.3	86	37	80	2675	1	*2
3	106.5	86	37	80	2705	1	*2
3. 1/16	109	86	42	85	2967	1	*2
3. 1/8	111.5	86	41	85	2996	1	*2
3. 1/4	115.3	86	44	90	3328	1	*2
3. 3/8	119	86	36	90	3389	1	*2
3. 1/2	124	86	40	95	3871	1	*2
New 3. 3/4	130.3	86	43	100	4377	1	*2
New 3. 7/8	135.3	86	47	105	5000	1	*2
New 4	137.8	86	46	105	5152	1	*2

*1 C-Ring=1801C, Pin/O-Ring=1801A/B
*2 C-Ring=1802C, Pin/O-Ring=1802A/B

 P250-251

18400M (mm)	D ₁ (mm)	D ₂ (mm)	ℓ (mm)	L (mm)			
	(mm)	(mm)	(mm)	(mm)	(g)	(pcs.)	
17	32.8	54	12	57	579	2	*1
18	34	54	13	57	586	2	*1
19	35.3	54	13	57	590	2	*1
21	37.8	54	15	57	605	2	*1
22	39	54	15	57	620	2	*1
23	40.3	54	16	57	615	2	*1
24	41.5	54	16	57	627	2	*1
25	42.8	54	16	57	620	2	*1
26	44	54	16	57	640	2	*1
27	45.3	54	16	57	627	2	*1
28	46.5	54	16	57	640	2	*1
29	47.8	54	18	57	657	2	*1
30	49	54	21	62	657	2	*1
31	50.3	54	21	62	687	2	*1
32	51.5	54	21	62	685	2	*1
33	52.8	54	21	62	685	2	*1
34	54	54	21	62	690	2	*1
35	55.3	54	21	62	710	2	*1
36	56.5	54	21	62	712	2	*1
37	57.8	54	21	62	735	2	*1
38	59	54	25	66	720	2	*1
New 39	60.3	54	25	66	820	2	*1
40	61.5	54	25	66	850	2	*1
41	62.8	54	25	66	850	2	*1
42	64	54	25	66	905	2	*1
43	65.3	54	27	68	977	2	*1
44	66.5	54	27	68	970	2	*1
45	67.8	54	27	68	963	2	*1
46	69	54	29	70	1010	2	*1
47	70.3	54	36	70	997	2	*1
48	71.5	54	35	70	990	2	*1
50	74	54	35	70	1065	2	*1
52	76.5	54	40	75	1185	2	*1
54	79	54	40	75	1252	2	*1
55	80.3	54	39	75	1260	2	*1
56	81.5	54	39	75	1277	2	*1
58	84	54	39	75	1340	2	*1
60	86.5	54	39	75	1400	2	*1
62	89	54	38	75	1410	2	*1
63	90.3	54	38	75	1383	2	*1
65	92.8	54	38	75	1630	2	*1
67	95.3	54	38	75	1580	2	*1
68	96.5	54	37	75	1583	1	*1
70	99	54	37	75	1625	1	*1
75	105.3	86	37	80	2675	1	*2
New 77	107.8	86	37	80	2890	1	*2
80	111.5	86	41	85	2996	1	*2
85	117.8	86	37	90	3378	1	*2
90	124	86	40	95	3871	1	*2
95	130.3	86	43	100	4500	1	*2
100	136.5	86	47	105	5000	1	*2

*1 C-Ring=1801C, Pin/O-Ring=1801A/B
*2 C-Ring=1802C, Pin/O-Ring=1802A/B

 P250-251

Impact Sockets Impact Steckschlüssel Douilles Impact



Z-SERIES

HAND

TITANIUM

SCREWDRIVERS

ACCESSORIES

IMPACT

SLEEVE-DRIVE

PROTECTOR

INDUSTRIAL

AUTOMOTIVE

MOTORCYCLE

CONSTRUCTION

SPARE PART

18401M 18401A

6-point Sockets, Thin Walled
6-kant Steckschlüssel, dünnwandig
Douilles à paroi mince, 6-pans

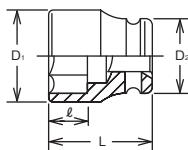

18401M (mm)	D ₁ (mm)	D ₂ (mm)	ℓ (mm)	L (mm)	(g)	(pcs.)	
17	29.8	53	12	57	481	2	*1
New 18	31	53	13	57	488	2	*1
19	32.3	53	13	57	492	2	*1
New 20	33.5	53	14	57	505	2	*1
21	34.8	53	15	57	512	2	*1
22	36	53	15	57	520	2	*1
24	38.5	53	16	57	520	2	*1
New 26	41	53	16	57	533	2	*1
27	42.3	53	16	57	540	2	*1
New 29	44.8	53	18	57	560	2	*1
30	46	53	21	62	572	2	*1
32	48.5	53	21	62	600	2	*1
33	49.8	53	21	62	613	2	*1
35	52.3	53	21	62	630	2	*1
36	53.5	53	21	62	635	2	*1
38	56	53	25	66	705	2	*1
41	59.8	53	25	66	740	2	*1
New 42	61	53	25	66	803	2	*1
46	66	53	29	70	900	2	*1
New 47	67.3	53	36	70	915	2	*1
50	71	53	35	70	940	2	*1

18401A (inch)	D ₁ (mm)	D ₂ (mm)	ℓ (mm)	L (mm)	(g)	(pcs.)	
11/16	29.8	53	12	57	481	2	*1
3/4	32.3	53	13	57	492	2	*1
13/16	34.8	53	15	57	512	2	*1
7/8	36	53	15	57	520	2	*1
15/16	38.5	53	16	57	520	2	*1
1. 1/16	42.3	53	16	57	540	2	*1
1. 3/16	46	53	21	62	572	2	*1
1. 1/4	48.5	53	21	62	600	2	*1
1. 3/8	52.3	53	21	62	630	2	*1
1. 1/2	56	53	25	66	705	2	*1
1. 5/8	59.8	53	25	66	740	2	*1
1.13/16	66	53	29	70	900	2	*1

*1 C-Ring=1801C, Pin/O-Ring=1801A/B → P250-251

18405M / 18405A

12-point Sockets
12-kant Steckschlüssel
Douilles 12-pans

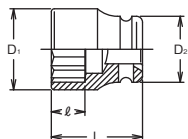

18405M (mm)	D ₁ (mm)	D ₂ (mm)	ℓ (mm)	L (mm)	(g)	(pcs.)	
New 24	41.5	54	16	57	627	2	*1
27	45.3	54	16	57	607	2	*1
30	49	54	21	62	657	2	*1
32	51.5	54	21	62	685	2	*1
33	52.8	54	21	62	690	2	*1
35	55.3	54	21	62	690	2	*1
36	56.5	54	21	62	692	2	*1
38	59	54	25	66	700	2	*1
40	61.5	54	25	66	830	2	*1
41	62.8	54	25	66	905	2	*1
46	69	54	29	70	990	2	*1
50	74	54	35	70	1021	2	*1
55	80.3	54	39	75	1234	2	*1
56	81.5	54	39	75	1250	2	*1
60	86.5	54	39	75	1400	2	*1
65	92.8	54	38	75	1600	2	*1
New 70	99	54	37	75	1625	1	*1
New 75	105.3	86	37	80	2675	1	*2
New 80	111.5	86	41	85	2996	1	*2

18405A (inch)	D ₁ (mm)	D ₂ (mm)	ℓ (mm)	L (mm)	(g)	(pcs.)	
3/4	35.3	54	13	57	590	2	*1
7/8	39	54	15	57	620	2	*1
1	42.8	54	16	57	620	2	*1
1. 1/8	47.8	54	18	57	660	2	*1
1. 3/16	49	54	21	62	660	2	*1
1. 1/4	51.5	54	21	62	690	2	*1
1. 3/8	55.3	54	21	62	710	2	*1
1. 7/16	57.8	54	21	62	735	2	*1
1. 1/2	59	54	25	66	720	2	*1
1. 3/4	67.8	54	27	68	970	2	*1
1.15/16	72.8	54	35	70	1000	2	*1

*1 C-Ring=1801C, Pin/O-Ring=1801A/B → P250-251

	18410M (mm)	D ₁ (mm)	D ₂ (mm)	ℓ (mm)	L (mm)	(g)	(pcs.)	⚠
New	24	41.5	54	16	57	627	2	*1
New	27	45.3	54	16	57	627	2	*1
New	30	49	54	21	62	657	2	*1
New	32	51.5	54	21	62	685	2	*1
New	33	52.8	54	21	62	685	2	*1
New	36	56.5	54	21	62	712	2	*1
New	41	62.8	54	25	66	850	2	*1

*1 C-Ring=1801C, Pin/O-Ring=1801A/B → P250-251

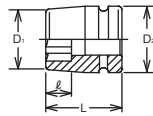

18410M

Surface Drive Sockets
Surface Drive Steckschlüssel
Douilles, Surface Drive



18405M (D)

Sockets for Cardan Shafts
Steckschlüssel für Gelenkwellen
Douilles pour arbres à cardan

No Warranty
Keine Garantie
Sans Garantie

	18405M (D) (mm)	D ₁ (mm)	D ₂ (mm)	ℓ (mm)	L (mm)	(g)	(pcs.)	⚠
	50(D68)	68	54	35	70	890	2	*1
	55(D76)	76	54	39	75	1130	2	*1
	65(D87)	87	54	38	75	1344	2	*1

*1 C-Ring=1801C, Pin/O-Ring=1801A/B → P250-251

Items in this catalogue marked ⚠ can be loaded to torque values which may cause breakage. In the interest of your own safety always apply load evenly and progressively to avoid breakage and possible injury.

Die mit ⚠ gekennzeichneten Artikel können bei Überbelastung zu Bruch gehen. Aus Gründen Ihrer eigenen Sicherheit sollten die betreffenden Werkzeuge nie ruckartig, sondern nach und nach belastet werden, um Bruch und damit verbundene mögliche Verletzungen zu vermeiden.

Il est possible d'appliquer aux articles marqués ⚠ des couples de serrage susceptibles d'occasionner leur rupture. Pour votre propre sécurité, veuillez toujours appliquer la charge d'une manière uniforme et progressive. Ceci pour éviter ruptures et accidents.

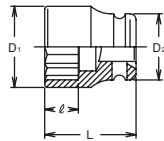

Impact Sockets

Impact Steckschlüssel

Douilles Impact



18301X



6-point Semi-Deep Sockets, Thin Walled
6-kant Steckschlüssel mittel lang, dünnwandig
Douilles à paroi mince semi-longues, 6-pans

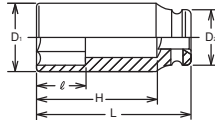

18301X (mm)	D ₁ (mm)	D ₂ (mm)	ℓ (mm)	H (mm)	L (mm)	⚖️ (g)	📦 (pcs.)	⚡
17	29.8	53	17	48	80	635	2	*1
19	32.3	53	19	48	80	655	2	*1
21	34.8	53	21	48	80	680	2	*1
22	36	53	22	48	80	686	2	*1
24	38.5	53	24	48	80	693	2	*1
27	42.3	53	27	48	80	745	2	*1
30	46	53	30	48	80	761	2	*1
32	48.5	53	32	53	85	770	2	*1
33	49.8	53	33	53	85	781	2	*1
35	52.3	53	35	53	85	800	2	*1
36	53.5	53	36	52	85	808	2	*1
38	56	53	38	52	85	865	2	*1
41	59.8	53	38	51	85	937	2	*1
46	66	53	38	50	85	1032	2	*1
50	71	53	55	-	85	1220	2	*1

*1 C-Ring=1801C, Pin/O-Ring=1801A/B → P250-251

18300M / 18300A



6-point Sockets, deep
6-kant Steckschlüssel, lang
Douilles 6-pans, longues

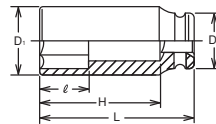

18300M (mm)	D ₁ (mm)	D ₂ (mm)	ℓ (mm)	H (mm)	L (mm)	⚖️ (g)	📦 (pcs.)	⚡
New 17	32.8	54	17	77	108	1000	2	*1
19	35.3	54	19	77	108	1010	2	*1
21	37.8	54	21	77	108	1010	2	*1
22	39	54	22	77	108	1010	2	*1
23	40.3	54	23	77	108	1063	2	*1
24	41.5	54	24	77	108	1060	2	*1
25	42.8	54	25	77	108	1085	2	*1
26	44	54	26	77	108	1133	2	*1
27	45.3	54	27	77	108	1125	2	*1
28	46.5	54	28	77	108	1140	2	*1
29	47.8	54	29	77	108	1120	2	*1
30	49	54	30	77	108	1179	2	*1
31	50.3	54	31	77	108	1125	2	*1
32	51.5	54	32	77	108	1200	2	*1
33	52.8	54	33	77	108	1200	2	*1
34	54	54	34	77	108	1280	2	*1
35	55.3	54	35	77	108	1300	2	*1
36	56.5	54	36	76	108	1280	2	*1
37	57.8	54	37	76	108	1320	2	*1
38	59	54	38	76	108	1423	2	*1
40	61.5	54	38	75	108	1415	2	*1
41	62.8	54	38	75	108	1450	2	*1
42	64	54	38	75	108	1550	2	*1
44	66.5	54	38	74	108	1636	2	*1
45	67.8	54	38	74	108	1660	2	*1
46	69	54	38	74	108	1680	2	*1
48	71.5	54	67	-	108	1500	2	*1
50	74	54	66	-	108	1650	2	*1
52	76.5	54	65	-	108	1770	2	*1
55	80.3	54	63	-	108	1855	2	*1
60	86.5	54	60	-	108	2047	2	*1
65	92.8	54	58	-	108	2310	2	*1
70	99	54	55	-	108	2440	1	*1
75	105.3	86	52	-	108	3646	1	*2
80	111.5	86	49	-	108	4039	1	*2
85	117.8	86	59	-	108	4000	1	*2
90	124	86	57	-	108	4200	1	*2
95	130.3	86	55	-	108	4400	1	*2

*1 C-Ring=1801C, Pin/O-Ring=1801A/B
*2 C-Ring=1802C, Pin/O-Ring=1802A/B

→ P250-251

18300A (inch)	D ₁ (mm)	D ₂ (mm)	ℓ (mm)	H (mm)	L (mm)	⚖️ (g)	📦 (pcs.)	⚡
11/16	32.8	54	17	77	108	978	2	*1
3/4	35.3	54	19	77	108	1010	2	*1
7/8	39	54	22	77	108	1010	2	*1
15/16	41.5	54	24	77	108	1060	2	*1
1	42.8	54	25	77	108	1085	2	*1
1. 1/16	45.3	54	27	77	108	1125	2	*1
1. 1/8	47.8	54	29	77	108	1120	2	*1
1. 3/16	49	54	30	77	108	1179	2	*1
1. 1/4	51.5	54	32	77	108	1200	2	*1
1. 5/16	54	54	34	77	108	1280	2	*1
1. 3/8	55.3	54	35	77	108	1300	2	*1
1. 7/16	57.8	54	37	76	108	1320	2	*1
1. 1/2	59	54	38	76	108	1423	2	*1
1. 9/16	61.5	54	38	75	108	1415	2	*1
1. 5/8	62.8	54	38	75	108	1450	2	*1
1.11/16	65.3	54	38	74	108	1577	2	*1
1. 3/4	67.8	54	38	74	108	1660	2	*1
1.13/16	69	54	38	74	108	1680	2	*1
1. 7/8	71.5	54	67	-	108	1500	2	*1
1.15/16	72.8	54	67	-	108	1570	2	*1
2	75.3	54	66	-	108	1605	2	*1
2. 1/16	76.5	54	65	-	108	1770	2	*1
2. 1/8	79	54	64	-	108	1812	2	*1
2. 3/16	80.3	54	63	-	108	1855	2	*1
2. 1/4	82.8	54	62	-	108	1916	2	*1
2. 5/16	84	54	61	-	108	1987	2	*1
2. 3/8	86.5	54	60	-	108	2047	2	*1
2. 7/16	89	54	59	-	108	2041	2	*1
2. 1/2	91.5	54	58	-	108	2250	2	*1
2. 9/16	92.8	54	58	-	108	2310	2	*1
2. 5/8	95.3	54	56	-	108	2370	1	*1
2. 3/4	99	54	55	-	108	2440	1	*1
2. 7/8	102.8	86	53	-	108	3600	1	*2
2.15/16	105.3	86	52	-	108	3646	1	*2
3	106.5	86	51	-	108	3677	1	*2
3. 1/16	109	86	50	-	108	3939	1	*2
3. 1/8	111.5	86	49	-	108	4039	1	*2
3. 3/16	112.8	86	48	-	108	4170	1	*2

*1 C-Ring=1801C, Pin/O-Ring=1801A/B
*2 C-Ring=1802C, Pin/O-Ring=1802A/B

→ P250-251

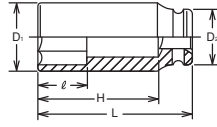

18301M 6-point Deep Sockets, Thin Walled 18301A 6-kant Steckschlüssel, dünnwandig Douilles à paroi mince longues, 6-pans



18301M (mm)	D ₁ (mm)	D ₂ (mm)	ℓ (mm)	H (mm)	L (mm)	(g)	(pcs.)	⚡
17	29.8	53	17	77	108	692	2	*1
18	31	53	18	77	108	710	2	*1
19	32.3	53	19	77	108	725	2	*1
20	33.5	53	20	77	108	740	2	*1
21	34.8	53	21	77	108	750	2	*1
22	36	53	22	77	108	770	2	*1
23	37.3	53	23	77	108	780	2	*1
24	38.5	53	24	77	108	800	2	*1
26	41	53	26	77	108	830	2	*1
27	42.3	53	27	77	108	860	2	*1
29	44.8	53	29	77	108	880	2	*1
30	46	53	30	77	108	910	2	*1
32	48.5	53	32	77	108	970	2	*1
33	49.8	53	33	77	108	980	2	*1
34	51	53	34	77	108	980	2	*1
35	52.3	53	35	77	108	986	2	*1
36	53.5	53	36	76	108	992	2	*1
38	56	53	38	76	108	1025	2	*1
39	57.3	53	38	76	108	1130	2	*1
41	59.8	53	38	75	108	1213	2	*1
New 42	61	53	38	75	108	1245	2	*1
43	62.3	53	38	74	108	1400	2	*1
46	66	53	38	74	108	1400	2	*1
50	71	53	38	-	108	1520	2	*1
New 55	77.3	53	62	-	108	1735	2	*1
New 60	83.5	53	59	-	108	1985	2	*1
New 65	89.8	53	56	-	108	2090	2	*1
New 70	96	53	55	-	108	2310	1	*1

18301A (inch)	D ₁ (mm)	D ₂ (mm)	ℓ (mm)	H (mm)	L (mm)	(g)	(pcs.)	⚡
11/16	29.8	53	17	77	108	692	2	*1
3/4	32.3	53	19	77	108	725	2	*1
13/16	34.8	53	21	77	108	750	2	*1
7/8	36	53	22	77	108	770	2	*1
15/16	38.5	53	24	77	108	800	2	*1
New 1	39.8	53	25	77	108	828	2	*1
New 1. 1/16	42.3	53	27	77	108	860	2	*1
New 1. 1/8	44.8	53	29	77	108	909	2	*1
1. 3/16	46	53	30	77	108	910	2	*1
1. 1/4	48.5	53	32	77	108	970	2	*1
New 1. 5/16	51	53	34	77	108	1014	2	*1
1. 3/8	52.3	53	35	77	108	986	2	*1
New 1. 7/16	54.8	53	37	76	108	1000	2	*1
New 1. 1/2	56	53	38	76	108	1025	2	*1
New 1. 9/16	58.5	53	38	75	108	1200	2	*1
1. 5/8	59.8	53	38	75	108	1213	2	*1
New 1.11/16	62.3	53	38	74	108	1285	2	*1
New 1. 3/4	64.8	53	38	74	108	1360	2	*1
1.13/16	66	53	38	74	108	1400	2	*1

*1 C-Ring=1801C, Pin/O-Ring=1801A/B → P250-251

18104M Special Sockets for Spring Clamps Steckschlüssel für Federbriden Douilles pour brides de ressorts

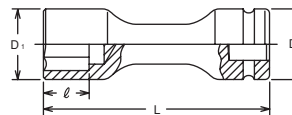

18104M (mm)	D ₁ (mm)	D ₂ (mm)	ℓ (mm)	L (mm)	(g)	(pce.)	⚡
24	41.5	54	24	170	1327	1	*1
27	45.3	54	27	170	1375	1	*1
28	46.5	54	28	170	1390	1	*1
30	49	54	30	170	1407	1	*1
32	51.5	54	32	170	1537	1	*1
33	52.8	54	33	170	1590	1	*1
34	54	54	34	170	1670	1	*1
36	56.5	54	36	170	1800	1	*1

*1 C-Ring=1801C, Pin/O-Ring=1801A/B → P250-251

18310M (mm)	D ₁ (mm)	D ₂ (mm)	ℓ (mm)	H (mm)	L (mm)	(g)	(pcs.)	⚡
New 24	41.5	54	24	77	108	1060	2	*1
New 27	45.3	54	27	77	108	1125	2	*1
New 30	49	54	30	77	108	1179	2	*1
New 32	51.5	54	32	77	108	1200	2	*1
New 33	52.8	54	33	77	108	1200	2	*1
New 36	56.5	54	36	76	108	1280	2	*1
New 41	62.8	54	38	75	108	1450	2	*1

*1 C-Ring=1801C, Pin/O-Ring=1801A/B → P250-251

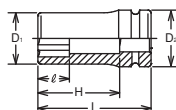

18310M Surface Drive Sockets, deep Surface Drive Steckschlüssel, lang Douilles longues, Surface Drive



Z-SERIES
HAND
TITANIUM
ACCESSORIES
SCREWDRIVERS
IMPACT
SLEEVE-DRIVE
PROTECTOR
INDUSTRIAL
AUTOMOTIVE
MOTORCYCLE
CONSTRUCTION
SPARE PART

Impact Sockets Impact Steckschlüssel Douilles Impact

1"

Z-SERIES
HAND
TITANIUM
SCREWDRIVERS ACCESSORIES
IMPACT
SLEEVE-DRIVE
PROTECTOR
INDUSTRIAL
AUTOMOTIVE
MOTORCYCLE
CONSTRUCTION
SPARE PART

18106

Bit Holder
Klingenhalter
Porte embouts



	D ₁ (mm)	D ₂ (mm)	ℓ (mm)	L (mm)	(g)	(pcs.)	
18106	32	54	16	68	640	2	*1

*1 C-Ring=1801C, Pin/O-Ring=1801A/B → P250-251

16106-SC

Replacement Screw : M6x10, 3mm

107-16

Bits for Inhex Screws
Klingen für Innensechskant-Schrauben
Embouts pour vis 6-pans males creux

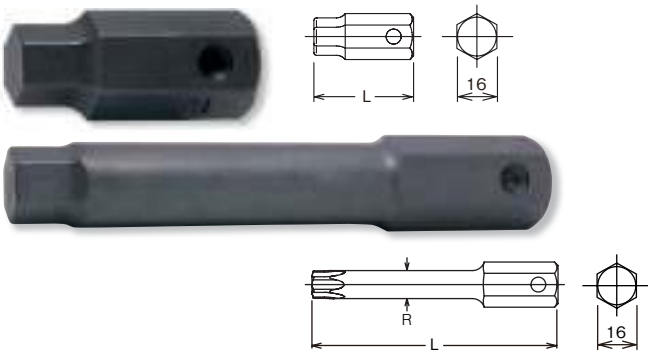

	107-16 (mm)	L (mm)	L (mm)	L=40 (g)	L=100 (g)	(pcs.)
New	10	40	100	46	122	10
New	12	40	100	52	146	10
	13	40	-	56	-	10
New	14	40	100	60	166	10
	16	40	-	69	-	10
New	17	40	100	73	193	10
	18	40	-	78	-	10
New	19	40	100	80	232	10
New	22	40	100	97	254	10

	107-16 (inch)	L (mm)	(g)	(pcs.)
New	3/8	40	45	10
	1/2	40	56	10
	9/16	40	60	10
	5/8	40	69	10
	3/4	40	80	10

107-16 (T)

TORX® Bits
TORX® Klingen
Embouts, TORX®

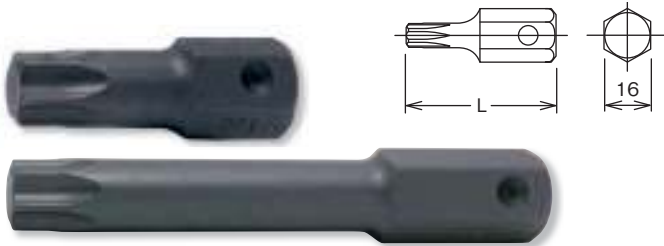

	107-16 (T)	L (mm)	L (mm)	L=50 (g)	L=100 (g)	(pcs.)
New	T55	50	100	57	108	10
New	T60	50	100	64	130	10
New	T70	50	100	73	159	10

107-16 (IP)

TORXPLUS® Bits
TORXPLUS® Klingen
Embouts TORXPLUS®



	107-16 (IP)	L (mm)	(g)	(pcs.)
	55IP	50	57	10
	60IP	50	64	10
	70IP	50	73	10

107-16 (XZN)

Bits XZN
Klingen XZN
Embouts de vissage, XZN



	107-16 (XZN)	L (mm)	L (mm)	L=60 (g)	L=100 (g)	(pcs.)
New	M14	60	100	83	131	10
New	M16	60	100	93	161	10
New	M18	60	100	103	177	10

18106-16

Bit Holder complete with Bit, Inhex
Klingenhalter komplett mit Klinge, Innensechskant
Porte embouts avec bit 6-pans creux



	18106-16 (mm)	D (mm)	H (mm)	L (mm)	(g)	(pcs.)	
	10	54	24	92	686	2	*1
	12	54	24	92	692	2	*1
	13	54	24	92	696	2	*1
	14	54	24	92	700	2	*1
	16	54	24	92	709	2	*1
	17	54	24	92	713	2	*1
	18	54	24	92	718	2	*1
	19	54	24	92	764	2	*1
	22	54	24	92	781	2	*1

	18106-16 (inch)	D (mm)	H (mm)	L (mm)	(g)	(pcs.)	
	1/2	54	24	92	696	2	*1
	9/16	54	24	92	700	2	*1
	5/8	54	24	92	709	2	*1
	3/4	54	24	92	764	2	*1

*1 C-Ring=1801C, Pin/O-Ring=1801A/B → P250-251

TORX is a registered trademark of Acument Intellectual Properties, LLC.
TORX® ist ein registriertes Markenzeichen der Firma Acument Intellectual Properties, LLC.
TORX® est une marque déposée de Acument Intellectual Properties, LLC.

TORXplus is a registered trademark of Acument Intellectual Properties, LLC.
TORXplus® ist ein registriertes Markenzeichen der Firma Acument Intellectual Properties, LLC.
TORXplus® est une marque déposée de Acument Intellectual Properties, LLC.

18107-22 (mm)	D (mm)	H (mm)	L (mm)	(g)	(pcs.)	
19	54	28	98	910	2	*1
22	54	28	98	932	2	*1
24	54	28	98	946	2	*1
27	54	28	98	986	2	*1
30	54	28	98	1008	2	*1
32	54	28	103	1029	2	*1

*1 C-Ring=1801C, Pin/O-Ring=1801A/B → P250-251



18107	D ₁ (mm)	D ₂ (mm)	ℓ (mm)	L (mm)	(g)	(pcs.)	
18107	44	54	22	70	770	2	*1

*1 C-Ring=1801C, Pin/O-Ring=1801A/B → P250-251

16107-SC

Replacement Screw : M8x14, ●4mm



18107-22 ● Bit Holder complete with Bit, Inhex
Klingenhalter komplett mit Klinge, Innensechskant
Porte embouts avec bit 6-pans creux

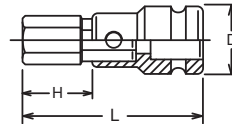

18107 ○ Bit Holder
Klingenhalter
Porte embouts

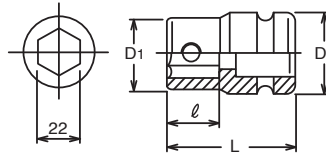

107-22 ● Bits for Inhex Screws
Klingen für Innensechskant-Schrauben
Embouts pour vis 6-pans males creux

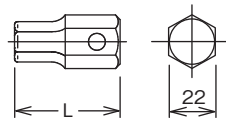

107-22 (mm)	L (mm)	(g)	(pcs.)
17	50	120	10
19	50	140	10
22	50	162	10
24	50	176	10
27	50	200	10
30	50	227	10
32	55	243	10

107-22 (inch)	L (mm)	(g)	(pcs.)
5/8	50	120	10
3/4	50	140	10
7/8	50	162	10
1	50	190	10
1. 1/4	55	243	10

107-22 (T)	L (mm)	(g)	(pcs.)
T 70	60	125	10
T 80	60	141	10
T 90	60	155	10
T100	60	170	10

107-22 (T) ● TORX® Bits
TORX® Klingen
Embouts, TORX®

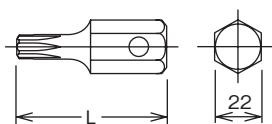

Z-SERIES
HAND
TITANIUM
ACCESSORIES
SCREWDRIVERS
IMPACT
SLEEVE-DRIVE
PROTECTOR
INDUSTRIAL
AUTOMOTIVE
MOTORCYCLE
CONSTRUCTION
SPARE PART

18760-175/-200/-250/-330

Extension Bars
Verlängerungen
Rallonges

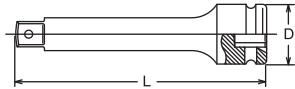

18760	D (mm)	L (mm)	(g)	(pce.)	(V)
175	54	175	1400	1	*1
200	54	200	1580	1	*1
250	54	250	1885	1	*1
330	54	330	2380	1	*1

*1 C-Ring=1801C, Pin/O-Ring=1801A/B → P250-251

18888AL

Adaptor (Quick Release)
Verbindungsstück (Quick Release)
Adaptateur (Quick Release)

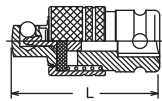

18888AL	L (mm)	(g)	(pcs.)	(V)
18888AL	95	980	2	*1

*1 C-Ring=1801C, Pin/O-Ring=1801A/B → P250-251

Lock & Quick Release

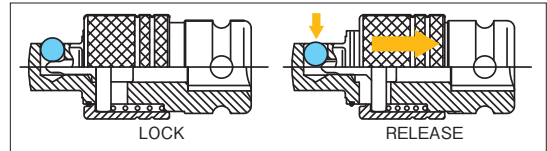

18770

Universal Joint
Gelenk-Einsatz
Joint articlé

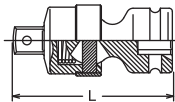

18770	L (mm)	(g)	(pce.)	(V)
18770	127	1210	1	*1
18771	115	1210	1	*1

*1 C-Ring=1801C, Pin/O-Ring=1801A/B → P250-251

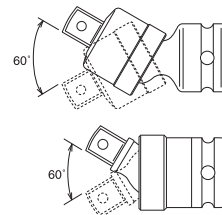

18771

Universal Joint
Gelenk-Einsatz
Joint articlé

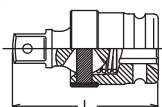

	(sq.)	(sq.)	L (mm)	(g)	(pce.)	
18866A	1"	3/4"	66.5	580	1	*1
18866A-200	1"	3/4"	200	1100	1	*1

*1 C-Ring=1801C, Pin/O-Ring=1801A/B → P250-251

⚠ Adapting down from bigger square drive to smaller square drive may lead to excessive torque load and possibly cause breakage. Always stay within safe torque of the smaller square drive.

Die mit **⚠** gekennzeichneten Artikel können bei Überbelastung zu Bruch gehen. Aus Gründen Ihrer eigenen Sicherheit sollten die betreffenden Werkzeuge nie ruckartig, sondern nach und nach belastet werden, um Bruch und damit verbundene mögliche Verletzungen zu vermeiden.

Il est possible d'appliquer aux articles marqués **⚠** des couples de serrage susceptibles d'occasionner leur rupture. Pour votre propre sécurité, veuillez toujours appliquer la charge d'une manière uniforme et progressive. Ceci pour éviter ruptures et accidents.

	(sq.)	(sq.)	L (mm)	(g)	(pce.)	
18877A	1"	1.1/2"	80	935	1	*1

*1 C-Ring=1801C, Pin/O-Ring=1801A/B → P250-251

18866A Adaptors
Verbindungsstücke
Réducteurs

No Warranty
Keine Garantie
Sans Garantie **⚠**

18866A-200 **⚠**

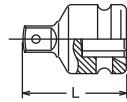

18877A Adaptor
Verbindungsstück
Augmentateur

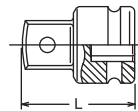

17400M / 17400A

6-point Sockets
6-kant Steckschlüssel
Douilles 6-pans

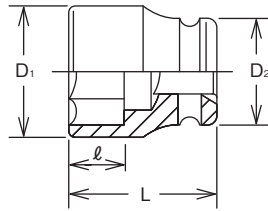

17400M (mm)	D ₁ (mm)	D ₂ (mm)	ℓ (mm)	L (mm)	(g)	(pce.)	⚡
36	62	86	20	77	2126	1	*1
41	68	86	22	80	2346	1	*1
42	70	86	22	80	2330	1	*1
46	74	86	26	84	2360	1	*1
50	79	86	27	84	2400	1	*1
52	82	86	38	84	2340	1	*1
54	84	86	38	84	2340	1	*1
55	85	86	44	90	2450	1	*1
58	88	86	44	90	2510	1	*1
60	91	86	43	90	2640	1	*1
65	97	86	48	95	3050	1	*1
70	103	86	52	100	3350	1	*1
75	108	86	56	105	3700	1	*1
80	115	86	60	110	4240	1	*1
85	122	86	60	110	4550	1	*1
90	128	86	60	112	4840	1	*1
95	135	127	52	112	7660	1	*2
100	140	127	53	115	7700	1	*2
105	146	127	57	120	8000	1	*2
110	153	127	60	124	9200	1	*2
115	160	127	62	128	10700	1	*2
120	166	127	64	132	11200	1	*2
125	173	127	67	136	13000	1	*2
130	180	127	69	140	14200	1	*2
135	186	127	73	145	14940	1	*2
140	190	127	76	150	15600	1	*2
150	200	127	83	160	16500	1	*2

17400A (inch)	D ₁ (mm)	D ₂ (mm)	ℓ (mm)	L (mm)	(g)	(pce.)	⚡
1. 5/8	68	86	22	80	2346	1	*1
1.11/16	71	86	22	80	2300	1	*1
1. 3/4	73	86	22	80	2290	1	*1
1.13/16	74	86	26	84	2360	1	*1
1. 7/8	77	86	26	84	2440	1	*1
1.15/16	79	86	27	84	2400	1	*1
2	80	86	27	84	2420	1	*1
2. 1/16	82	86	38	84	2340	1	*1
2. 1/8	84	86	38	84	2340	1	*1
2. 3/16	85	86	44	90	2450	1	*1
2. 1/4	87	86	43	90	2460	1	*1
2. 5/16	88	86	44	90	2510	1	*1
2. 3/8	91	86	43	90	2640	1	*1
2. 7/16	93	86	47	95	2860	1	*1
2. 1/2	96	86	47	95	3000	1	*1
2. 9/16	97	86	48	95	3050	1	*1
2. 5/8	100	86	51	100	3300	1	*1
2.11/16	101	86	51	100	3300	1	*1
2. 3/4	103	86	52	100	3350	1	*1
2.13/16	105	86	55	105	3670	1	*1
2. 7/8	106	86	55	105	3610	1	*1
2.15/16	108	86	56	105	3700	1	*1
3	108	86	55	105	3680	1	*1
3. 1/8	115	86	60	110	4240	1	*1
3. 1/4	118	86	59	110	4370	1	*1
3. 3/8	123	86	60	110	4570	1	*1
3. 1/2	128	86	60	112	4840	1	*1
3. 5/8	132	86	52	112	5500	1	*1
3. 3/4	135	127	52	112	7660	1	*2
3. 7/8	140	127	53	115	7700	1	*2
4	146	127	57	120	8000	1	*2
4. 1/8	146	127	57	120	8000	1	*2
4. 1/4	153	127	60	124	9200	1	*2
4. 1/2	160	127	62	128	10700	1	*2
4. 5/8	166	127	64	132	11200	1	*2
4. 3/4	168	127	64	132	11200	1	*2
4. 7/8	173	127	67	136	13000	1	*2
5	180	127	69	140	14200	1	*2
5. 1/4	186	127	73	145	14940	1	*2
6	205	127	88	165	16500	1	*2
6. 1/2	205	127	94	175	17500	1	*2

*1 C-Ring=1700C, Pin/O-Ring=1701A/B
*2 Pin/O-Ring=1702A/B

→ P250-251

1-1/2" Impact Sockets

Impact Steckschlüssel

Douilles Impact

Z-SERIES HAND TITANIUM ACCESSORIES SCREWDRIVERS IMPACT SLEEVE-DRIVE PROTECTOR INDUSTRIAL AUTOMOTIVE MOTORCYCLE CONSTRUCTION SPARE PART

17405M (mm)	D ₁ (mm)	D ₂ (mm)	ℓ (mm)	L (mm)	(g)	(pce.)	
46	74	86	26	84	2360	1	*1
50	79	86	27	84	2400	1	*1
55	85	86	44	90	2450	1	*1
60	91	86	43	90	2640	1	*1
65	97	86	48	95	3050	1	*1
70	103	86	52	100	3350	1	*1
75	108	86	56	105	3700	1	*1
80	115	86	60	110	4240	1	*1
85	122	86	60	110	4550	1	*1
90	128	86	60	112	4840	1	*1
New 95	135	127	52	112	7660	1	*1
New 100	140	127	53	115	7700	1	*1

17405A (inch)	D ₁ (mm)	D ₂ (mm)	ℓ (mm)	L (mm)	(g)	(pce.)	
1.11/16	71	86	22	80	2300	1	*1
1. 3/4	73	86	22	80	2290	1	*1
1. 7/8	77	86	26	84	2440	1	*1
1.15/16	79	86	27	84	2400	1	*1
2	80	86	27	84	2420	1	*1
2. 1/16	82	86	38	84	2340	1	*1
2. 1/8	84	86	38	84	2340	1	*1
2. 3/16	85	86	44	90	2450	1	*1
2. 1/4	87	86	43	90	2460	1	*1
2. 3/8	91	86	43	90	2640	1	*1
2. 7/16	93	86	47	95	2860	1	*1
2. 1/2	96	86	47	95	3000	1	*1
2. 9/16	97	86	48	95	3050	1	*1
2. 5/8	100	86	51	100	3300	1	*1

*1 C-Ring=1700C, Pin/O-Ring=1701A/B → P250-251

17405M / 17405A

12-point Sockets
12-kant Steckschlüssel
Douilles 12-pans

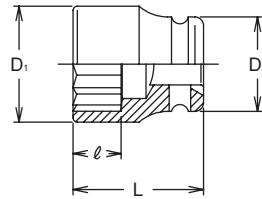

17300M / 17300A

6-point Deep Sockets
6-kant-Steckschlüssel,lang
Douilles longues 6-pans

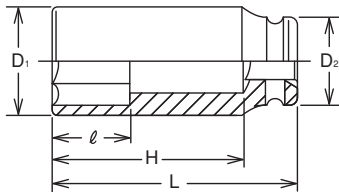

17300M (mm)	D ₁ (mm)	D ₂ (mm)	ℓ (mm)	H (mm)	L (mm)	(g)	(pce.)	
New 36	63	86	26	70.5	115	2800	1	*1
41	68	86	27	70.5	115	3080	1	*1
42	70	86	27	70.5	115	3140	1	*1
46	74	86	28	80.5	125	3440	1	*1
50	79	86	30	90.5	135	3840	1	*1
54	84	86	30	90.5	135	4160	1	*1
55	85	86	33	90.5	135	4130	1	*1
60	91	86	35	90.5	135	4370	1	*1
65	97	86	38	99.5	145	5260	1	*1
70	103	86	40	98.5	145	5780	1	*1
75	108	86	42	107.5	155	6580	1	*1
80	115	86	46	115.5	165	7740	1	*1
85	122	86	49	114.5	165	7420	1	*1
90	128	86	52	122.5	175	9630	1	*1
95	135	127	55	121.5	175	10450	1	*2
100	140	127	58	130.5	185	9741	1	*2
105	146	127	62	138.5	195	10850	1	*2
110	153	127	65	137.5	195	11500	1	*2
115	160	127	68	135.5	195	12160	1	*2
120	166	127	72	144.5	205	13680	1	*2
125	173	127	74	142.5	205	14450	1	*2
130	180	127	76	142.5	205	15190	1	*2

*1 C-Ring=1700C, Pin/O-Ring=1701A/B → P250-251
*2 Pin/O-Ring=1702A/B

17300A (inch)	D ₁ (mm)	D ₂ (mm)	ℓ (mm)	H (mm)	L (mm)	(g)	(pce.)	
1. 5/8	68	86	27	70.5	115	3080	1	*1
1.11/16	71	86	27	70.5	115	3180	1	*1
1. 3/4	73	86	27	70.5	115	3210	1	*1
1.13/16	74	86	28	80.5	125	3440	1	*1
1. 7/8	77	86	28	80.5	125	3550	1	*1
1.15/16	79	86	28	80.5	125	3590	1	*1
2	80	86	30	90.5	135	3916	1	*1
2. 1/16	82	86	30	90.5	135	4030	1	*1
2. 1/8	84	86	30	90.5	135	4160	1	*1
2. 3/16	85	86	33	90.5	135	4200	1	*1
2. 1/4	87	86	33	90.5	135	4160	1	*1
2. 3/8	91	86	35	90.5	135	4370	1	*1
2. 7/16	93	86	35	90.5	135	4490	1	*1
2. 1/2	96	86	35	90.5	135	4630	1	*1
2. 9/16	97	86	38	99.5	145	5260	1	*1
2. 5/8	100	86	38	99.5	145	5320	1	*1
2.11/16	101	86	38	99.5	145	5670	1	*1
2. 3/4	103	86	40	98.5	145	5780	1	*1
2.13/16	105	86	40	98.5	145	6000	1	*1
2. 7/8	106	86	40	98.5	145	6080	1	*1
2.15/16	108	86	42	107.5	155	6580	1	*1
3	108	86	42	107.5	155	6850	1	*1
3. 1/8	115	86	46	115.5	165	7740	1	*1
3. 3/4	135	127	55	121.5	175	12200	1	*2
3. 7/8	140	127	56	120.5	175	11080	1	*2

*1 C-Ring=1700C, Pin/O-Ring=1701A/B → P250-251
*2 Pin/O-Ring=1702A/B

Z-SERIES
HAND
TITANIUM
SCREWDRIVERS
ACCESSORIES
IMPACT
SLEEVE-DRIVE
PROTECTOR
INDUSTRIAL
AUTOMOTIVE
MOTORCYCLE
CONSTRUCTION
SPARE PART

17108 Bit Holder Klingenhalter Porte-embouts

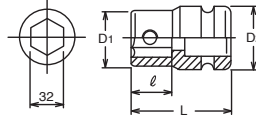

	D ₁ (mm)	D ₂ (mm)	ℓ (mm)	L (mm)	(g)	(pce.)	
17108	60	86	30	85	2200	1	*1

*1 C-Ring=1700C, Pin/O-Ring=1701A/B → P250-251

16107-SC

 Replacement Screw : M8x14, ●4mm
Ersatzschraube : M8x14, ●4mm
Vis de remplacement : M8x14, ●4mm

107-32 Bit for Inhex Screws Klingen für Innensechskant-Schrauben Embouts pour vis 6-pans mâle creux

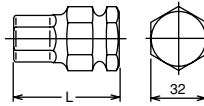

107-32 (mm)	L (mm)	(g)	(pcs.)
19	60	300	10
22	60	320	10
24	60	330	10
27	60	360	10
30	60	390	10
32	60	410	10
36	60	460	10

17108-32 Bit Holder complete with Bit Klingenhalter, komplett mit Klinge Porte embouts avec bit

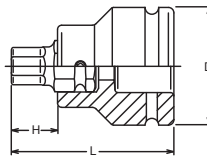

17108-32 (mm)	D (mm)	H (mm)	L (mm)	(g)	(pce.)	
19	86	30	115	2500	1	*1
22	86	30	115	2520	1	*1
24	86	30	115	2530	1	*1
27	86	30	115	2560	1	*1
30	86	30	115	2590	1	*1
32	86	30	115	2610	1	*1
36	86	30	115	2660	1	*1

*1 C-Ring=1700C, Pin/O-Ring=1701A/B → P250-251



1-1/2"

Impact Sockets
Impact Steckschlüssel
Douilles Impact

17760	D (mm)	L (mm)	(g)	(pce.)	⚡
175	86	175	3300	1	*1
250	86	250	4500	1	*1
330	86	330	5200	1	*1

*1 C-Ring=1700C, Pin/O-Ring=1701A/B → P250-251

17760-175/-250/-330

Extension Bars
Verlängerungen
Rallonges

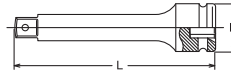

17770	L (mm)	(g)	(pce.)	⚡
17770	200	4700	1	*1

*1 C-Ring=1700C, Pin/O-Ring=1701A/B → P250-251

17770

Universal Joint
Gelenk-Einsatz
Joint articlé

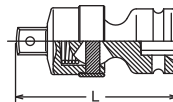

17788A	(sq.)	(sq.)	L (mm)	(g)	(pce.)	⚡
17788A	1.1/2"	1"	98	2600	1	*1

*1 C-Ring=1700C, Pin/O-Ring=1701A/B → P250-251

⚠ Adapting down from bigger square drive to smaller square drive may lead to excessive torque load and possibly cause breakage. Always stay within safe torque of the smaller square drive.

Die mit **⚠** gekennzeichneten Artikel können bei Überbelastung zu Bruch gehen. Aus Gründen Ihrer eigenen Sicherheit sollten die betreffenden Werkzeuge nie ruckartig, sondern nach und nach belastet werden, um Bruch und damit verbundene mögliche Verletzungen zu vermeiden.

Il est possible d'appliquer aux articles marqués **⚠** des couples de serrage susceptibles d'occasionner leur rupture. Pour votre propre sécurité, veuillez toujours appliquer la charge d'une manière uniforme et progressive. Ceci pour éviter ruptures et accidents.

17788A

⚠ Adaptor
Verbindungsstück
Réducteur

No Warranty
Keine Garantie
Sans Garantie

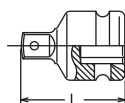

17799A	(sq.)	(sq.)	L (mm)	(g)	(pce.)	⚡
17799A	1.1/2"	2.1/2"	115	3790	1	*1

*1 C-Ring=1700C, Pin/O-Ring=1701A/B → P250-251

17799A

Adaptor
Verbindungsstück
Augmentateur

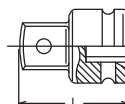

Z-SERIES
HAND
TITANIUM
ACCESSORIES
SCREWDRIVERS
IMPACT
SLEEVE-DRIVE
PROTECTOR
INDUSTRIAL
AUTOMOTIVE
MOTORCYCLE
CONSTRUCTION
SPARE PART

19400M / 19400A

6-point Sockets
6-kant Steckschlüssel
Douilles 6-pans

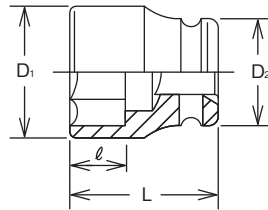

19400M (mm)	D ₁ (mm)	D ₂ (mm)	ℓ (mm)	L (mm)	⚖️ (g)	📦 (pce.)	⚡
50	88	127	39	115	7270	1	*1
55	94	127	42	115	7350	1	*1
60	100	127	45	125	7870	1	*1
65	105	127	48	125	7790	1	*1
70	110	127	51	125	7640	1	*1
75	118	127	54	125	7740	1	*1
80	124	127	57	125	7640	1	*1
85	127	127	61	132	7840	1	*1
90	135	127	64	132	8500	1	*1
95	140	127	71	140	10160	1	*1
100	146	127	71	142	11500	1	*1
105	155	127	74	146	11350	1	*1
110	160	127	76	155	12710	1	*1
115	167	127	78	158	13980	1	*1
120	175	175	79	160	15430	1	*2
125	180	175	82	165	16590	1	*2
130	185	175	85	169	17590	1	*2
135	190	175	89	175	19030	1	*2
140	200	175	93	180	21810	1	*2
145	205	175	95	183	24440	1	*2
150	210	175	97	192	25720	1	*2
160	225	175	102	200	30920	1	*2
165	230	175	105	204	32610	1	*2
170	235	175	106	207	34390	1	*2
175	240	175	109	211	36210	1	*2
180	250	175	110	214	40630	1	*2
185	255	175	113	218	42690	1	*2
190	265	175	113	220	47440	1	*2
200	275	175	116	225	51550	1	*2
210	285	175	123	235	57170	1	*2
215	290	175	126	240	60260	1	*2
225	305	175	133	250	70180	1	*2
235	315	175	140	260	77060	1	*2

19400A (inch)	D ₁ (mm)	D ₂ (mm)	ℓ (mm)	L (mm)	⚖️ (g)	📦 (pce.)	⚡
2. 1/8	92	127	41	115	6665	1	*1
2. 3/8	100	127	45	125	7870	1	*1
2. 7/16	102	127	46	125	7840	1	*1
2. 1/2	103	127	47	125	7810	1	*1
2. 9/16	105	127	48	125	7790	1	*1
2. 5/8	107	127	49	125	7790	1	*1
2.11/16	108	127	50	125	7790	1	*1
2. 3/4	110	127	51	125	7640	1	*1
2.13/16	113	127	52	125	7690	1	*1
2. 7/8	115	127	53	125	7730	1	*1
2.15/16	118	127	54	125	7740	1	*1
3	120	127	55	125	7740	1	*1
3. 1/8	124	127	57	125	7640	1	*1
3. 1/4	125	127	59	125	7740	1	*1
3. 3/8	127	127	61	132	7840	1	*1
3. 1/2	135	127	64	132	8500	1	*1
3. 5/8	138	127	64	132	9330	1	*1
3. 3/4	140	127	71	140	10160	1	*1
3. 7/8	143	127	70	140	10830	1	*1
4	146	127	71	142	11500	1	*1
4. 1/8	155	127	70	142	11250	1	*1
4. 1/4	160	127	76	155	12710	1	*1
4. 3/8	163	127	76	155	13100	1	*1
4. 1/2	167	127	78	158	13980	1	*1
4. 5/8	175	175	79	160	15430	1	*2
4. 7/8	180	175	82	165	16590	1	*2
5	183	175	81	165	17090	1	*2
5. 1/4	190	175	89	175	19030	1	*2
5. 3/8	198	175	94	180	20880	1	*2
5. 1/2	200	175	93	180	21810	1	*2
5. 5/8	203	175	94	182	22480	1	*2
5. 3/4	207	175	103	192	24440	1	*2
6	217	175	100	196	28510	1	*2
6. 1/8	218	175	99	196	29720	1	*2
6. 5/8	233	175	105	205	33500	1	*2
7	248	175	110	213	39160	1	*2

*1 Pin/O-Ring=1901A/B
*2 Pin/O-Ring=1902A/B

➔ P251

2-1/2"

Impact Sockets
Impact Steckschlüssel
Douilles Impact

Z-SERIES
HAND
TITANIUM
ACCESSORIES
SCREWDRIVERS
IMPACT
SLEEVE-DRIVE
PROTECTOR
INDUSTRIAL
AUTOMOTIVE
MOTORCYCLE
CONSTRUCTION
SPARE PART

19300M (mm)	D ₁ (mm)	D ₂ (mm)	ℓ (mm)	H (mm)	L (mm)	(g)	(pce.)	⚡
75	118	127	42	129	190	11930	1	*1
80	124	127	46	129	190	12280	1	*1
85	127	127	49	134	195	12480	1	*1
90	135	127	52	144	205	14000	1	*1
95	140	127	55	149	210	14630	1	*1
100	146	127	58	154	215	15520	1	*1
105	155	127	62	146.5	220	18250	1	*1
110	160	127	65	150.5	225	18740	1	*1
115	167	127	68	153.5	230	20940	1	*1
120	175	175	72	157.5	235	23530	1	*2
125	180	175	74	158.5	238	26110	1	*2
130	185	175	76	163.5	243	25320	1	*2
135	190	175	80	165.5	248	26290	1	*2
140	200	175	82	164.5	248	28940	1	*2
145	205	175	84	163.5	248	29520	1	*2
150	210	175	88	168.5	255	30600	1	*2
155	215	175	92	167.5	255	31680	1	*2
160	225	175	95	170.5	260	35560	1	*2
165	230	175	98	169.5	260	36040	1	*2
170	235	175	100	172.5	265	37230	1	*2
175	240	175	102	176.5	270	39420	1	*2

*1 Pin/O-Ring=1901A/B → P251
*2 Pin/O-Ring=1902A/B

19300M



6-point Deep Sockets
6-kant-Steckschlüssel, lang
Douilles longues 6-pans

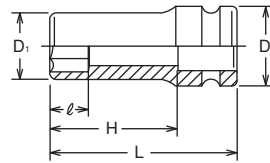

19760	D (mm)	L (mm)	(g)	(pce.)	⚡
250	127	250	17800	1	*1
500	127	500	27800	1	*1

*1 Pin/O-Ring=1901A/B → P251

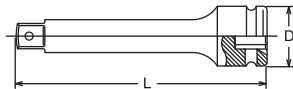

19760-250/-500

Extension Bars
Verlängerungen
Rallonges



19770	L (mm)	(g)	(pce.)	⚡
19770	303	21360	1	*1

*1 Pin/O-Ring=1901A/B → P251

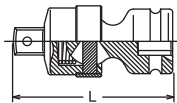

19770

Universal Joint
Gelenk-Einsatz
Joint articlé



19977A	(sq.)	(sq.)	L (mm)	(g)	(pce.)	⚡
19977A	2.1/2"	1.1/2"	145	7210	1	*1

*1 Pin/O-Ring=1901A/B → P251

⚠ Adapting down from bigger square drive to smaller square drive may lead to excessive torque load and possibly cause breakage. Always stay within safe torque of the smaller square drive.

Die mit **⚠** gekennzeichneten Artikel können bei Überbelastung zu Bruch gehen. Aus Gründen Ihrer eigenen Sicherheit sollten die betreffenden Werkzeuge nie ruckartig, sondern nach und nach belastet werden, um Bruch und damit verbundene mögliche Verletzungen zu vermeiden.

Il est possible d'appliquer aux articles marqués **⚠** des couples de serrage susceptibles d'occasionner leur rupture. Pour votre propre sécurité, veuillez toujours appliquer la charge d'une manière uniforme et progressive. Ceci pour éviter ruptures et accidents.

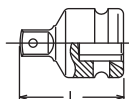

19977A

Adaptor
Verbindungsstück
Réducteur

No Warranty
Keine Garantie
Sans Garantie **⚠**



10400M / 10400A

6-point Sockets
6-kant Steckschlüssel
Douilles 6-pans

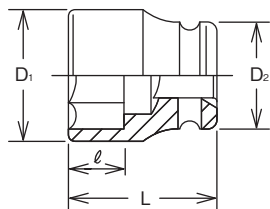

10099A

Adaptor
Verbindungsstück
Réducteur

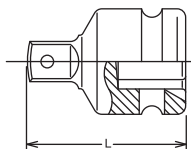

10400M (mm)	D ₁ (mm)	D ₂ (mm)	ℓ (mm)	L (mm)	⚖️ (g)	📦 (pce.)	⚡
105	165	175	86	176	19370	1	*1
110	170	175	88	179	20160	1	*1
115	175	175	90	183	21160	1	*1
120	180	175	91	185	21930	1	*1
125	188	175	94	190	23940	1	*1
130	193	175	97	194	25050	1	*1
135	200	175	101	199	26930	1	*1
140	205	175	105	205	28560	1	*1
145	210	200	106	207	29600	1	*2
150	215	200	109	212	31240	1	*2
160	228	200	114	220	35500	1	*2
165	235	200	117	224	37940	1	*2
170	240	200	118	227	39660	1	*2
175	245	200	121	231	41400	1	*2
180	255	200	122	234	45740	1	*2
185	265	200	125	238	50350	1	*2
190	275	200	125	239	54650	1	*2
200	285	200	128	245	59190	1	*2
210	295	200	135	255	64970	1	*2
215	300	200	138	260	68150	1	*2

10400A (inch)	D ₁ (mm)	D ₂ (mm)	ℓ (mm)	L (mm)	⚖️ (g)	📦 (pce.)	⚡
4.1/8	165	175	86	176	19370	1	*1
4.1/4	168	175	87	178	19770	1	*1
4.3/8	172	175	88	180	20660	1	*1
4.1/2	175	175	89	182	21160	1	*1
4.5/8	178	175	90	183	21550	1	*1
4.3/4	180	175	91	185	21930	1	*1
4.7/8	188	175	94	190	23940	1	*1
5	188	175	95	191	24500	1	*1
5.1/8	193	175	97	194	25050	1	*1
5.1/4	197	175	100	198	25990	1	*1
5.3/8	201	175	102	202	27750	1	*1
5.1/2	205	175	105	205	28560	1	*1
5.5/8	208	200	106	208	30110	1	*2
5.3/4	212	200	108	210	30610	1	*2
5.7/8	215	200	109	212	31240	1	*2
6	219	200	110	214	32460	1	*2
6.1/8	223	200	112	216	33670	1	*2
6.1/4	227	200	114	218	34590	1	*2
6.3/8	231	200	115	221	36720	1	*2
6.1/2	235	200	117	224	37940	1	*2
6.5/8	238	200	118	226	38800	1	*2
6.3/4	241	200	119	228	39870	1	*2
6.7/8	245	200	120	230	40640	1	*2
7	251	200	121	232	43570	1	*2
7.1/8	257	200	122	234	46450	1	*2
7.1/4	263	200	123	236	48400	1	*2
7.3/8	269	200	124	238	52500	1	*2
7.1/2	275	200	125	240	55350	1	*2
7.5/8	278	200	127	242	56050	1	*2
7.3/4	282	200	129	245	57620	1	*2
7.7/8	285	200	130	248	60870	1	*2
8	290	200	132	250	62550	1	*2
8.1/8	293	200	133	251	63760	1	*2
8.1/4	295	200	135	255	64970	1	*2
8.3/8	298	200	136	258	65580	1	*2
8.1/2	300	200	138	260	68150	1	*2
8.5/8	305	200	139	262	70760	1	*2
8.3/4	310	200	140	264	73830	1	*2
8.7/8	313	200	142	267	75780	1	*2

*1 Pin/O-Ring=2001A/B

➔ P251

*2 Pin/O-Ring=2002A/B

10099A	⚡ (sq.)	⚡ (sq.)	L (mm)	⚖️ (g)	📦 (pce.)	⚡
10099A	3.1/2"	2.1/2"	182	16870	1	*1

*1 Pin/O-Ring=2001A/B

➔ P251

⚠️ Adapting down from bigger square drive to smaller square drive may lead to excessive torque load and possibly cause breakage. Always stay within safe torque of the smaller square drive.

Die mit ⚠️ gekennzeichneten Artikel können bei Überbelastung zu Bruch gehen. Aus Gründen Ihrer eigenen Sicherheit sollten die betreffenden Werkzeuge nie ruckartig, sondern nach und nach belastet werden, um Bruch und damit verbundene mögliche Verletzungen zu vermeiden.

Il est possible d'appliquer aux articles marqués ⚠️ des couples de serrage susceptibles d'occasionner leur rupture. Pour votre propre sécurité, veuillez toujours appliquer la charge d'une manière uniforme et progressive. Ceci pour éviter ruptures et accidents.

SLEEVE-DRIVE SOCKETS

SLEEVE-DRIVE STECKSCHLÜSSEL

DOUILLES, SLEEVE DRIVE

3/8"

1/2"

3/4"



Sleeve-Drive Sockets
 Sleeve-Drive Steckschlüssel
 Douilles, Sleeve Drive



The deepened drive end of the **Sleeve-Drive** tools prevents the sometimes "wobbly" connection between pulse tool - extension - socket. An O-ring inside **Sleeve-Drive** optimizes the perfect fit of extension bars and sockets on the anvil to the effect, that the exactness of the required torque given by the pulse tool is generally improved. Further, the **Sleeve-Drive** avoids the direct transmission of vibrations on the pulse tool and finally on the operator.

Der **Sleeve-Drive** Vierkant-Antrieb vermeidet durch die vertiefte Passung den "Wackelkontakt" zwischen Maschine - Verlängerung - Steckschlüssel. Ein im **Antriebsende der Sleeve-Drive-Steckschlüssel** eingesetzter Ring optimiert den festen Sitz der Verlängerungen und Steckschlüssel auf der Schrauberspindel und sorgt somit für die unmittelbare Weitergabe des vorgegebenen Drehmomentes ohne wesentliche Drehkraftverluste. Nicht zuletzt vermeidet der **Sleeve-Drive** Antrieb die Übertragung von Schwingungen auf Mensch und Maschine.

Ces nouveaux outils **Sleeve-Drive** se caractérisent par un entraînement carré allongé et un joint torique incorporé. Le guidage rigide ainsi obtenu maintient les outils **Sleeve-Drive** dans l'axe de la broche de la machine et garantit une connection optimale machine-rallonges-douilles. Le jeu latéral et les vibrations engendrés par les outils traditionnels sont de ce fait supprimés. Il en résulte une transmission plus précise du coupe de serrage et un plus grand confort de travail pour l'opérateur.

Sleeve Drive Sockets

Wrenches

O-Ring



SLEEVE DRIVE SOCKET

PULSE TOOL

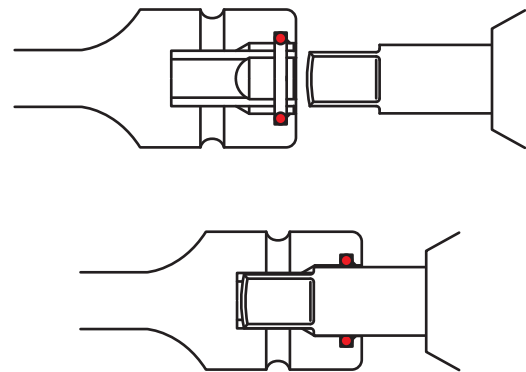

The "**Sleeve Drive**" Sockets and accessories are designed for use on Pulse Tools with anvils of certain lengths and diameters as shown hereunder.

Die serienmässigen "**Sleeve Drive**" Steckschlüssel können nur auf Impuls Schraubern mit Antriebswellen der nachstehenden Längen und Durchmesser gesteckt werden.

Les douilles "**Sleeve Drive**" ne peuvent être placées que sur des axes des boulonneuses à impulsions d'une longueur et d'un diamètre selon la spécification ci-dessous.

	Anvil Diameter (mm)	Minimum Anvil Length (mm)
3/8"sq.	12	10
1/2"sq.	16	10
3/4"sq.	25	11.8

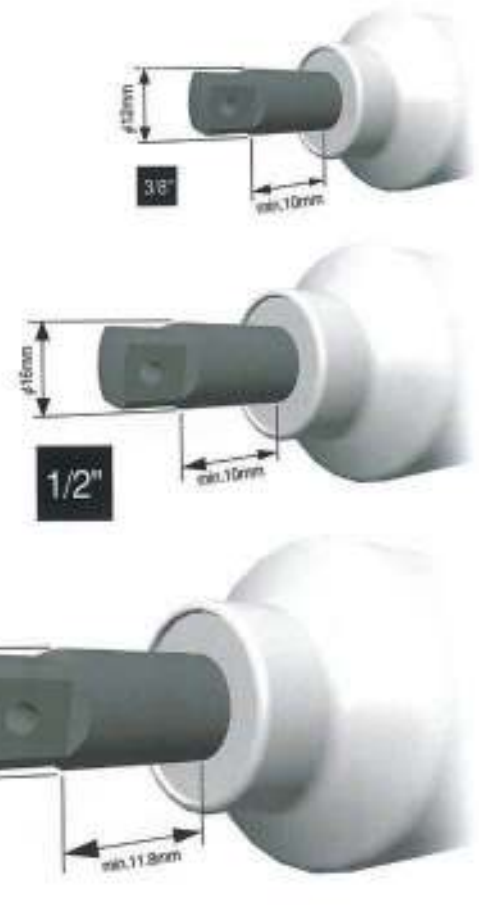

3/8"

Sleeve-Drive Sockets
Sleeve-Drive Steckschlüssel
Douilles, Sleeve Drive

Z-SERIES
HAND
TITANIUM
ACCESSORIES
SCREWDRIVERS
IMPACT
SLEEVE-DRIVE
PROTECTOR
INDUSTRIAL
AUTOMOTIVE
MOTORCYCLE
CONSTRUCTION
SPARE PART

NV13400 (mm)	D ₁ (mm)	D ₂ (mm)	ℓ (mm)	L (mm)	(g)	(pcs.)	⚡
New 8	13.3	19	6	43	53	10	*1
10	15.8	19	7	43	53	10	*1
11	17	19	8	43	54	10	*1
12	18.3	19	9	43	55	10	*1
13	19.5	22	10	43	80	10	*2
14	20.8	22	10	43	80	10	*2
15	22	22	11	43	81	10	*2
16	23.3	22	11	43	83	10	*2
17	24.5	22	11	43	85	10	*2
18	25.8	22	11	43	89	10	*2
19	27	22	11	43	98	10	*2
21	29.5	22	11	43	105	10	*2
22	30.8	22	11	43	112	10	*2

*1 C-Ring=1301C, Pin/O-Ring=1301A/B
*2 C-Ring=1302C, Pin/O-Ring=1302A/B → P250-251

NV13400



6-point Sockets
6-kant Steckschlüssel
Douilles 6-pans

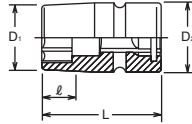

NV13145-100 (mm)	D ₁ (mm)	D ₂ (mm)	ℓ (mm)	L (mm)	(g)	(pcs.)	⚡
6	13	19	6	100	108	10	*1
8	13	19	8	100	110	10	*1
10	15.5	19	10	100	112	10	*1
12	18	19	12	100	120	10	*1
13	19	19	13	100	127	10	*1
14	21	19	14	100	131	10	*1
15	22	19	15	100	133	10	*1
16	24	19	15	100	144	10	*1
17	25	19	15	100	154	10	*1

NV13145-150 (mm)	D ₁ (mm)	D ₂ (mm)	ℓ (mm)	L (mm)	(g)	(pcs.)	⚡
6	13	19	6	150	160	10	*1
8	13	19	8	150	160	10	*1
10	15.5	19	10	150	165	10	*1
12	18	19	12	150	168	10	*1
13	19	19	13	150	170	10	*1
14	21	19	14	150	175	10	*1
15	22	19	15	150	177	10	*1
16	24	19	15	150	190	10	*1
17	25	19	15	150	203	10	*1

NV13145-200 (mm)	D ₁ (mm)	D ₂ (mm)	ℓ (mm)	L (mm)	(g)	(pcs.)	⚡
6	13	19	6	200	210	10	*1
8	13	19	8	200	210	10	*1
10	15.5	19	10	200	212	10	*1
12	18	19	12	200	214	10	*1
13	19	19	13	200	218	10	*1
14	21	19	14	200	220	10	*1
15	22	19	15	200	226	10	*1
16	24	19	15	200	235	10	*1
17	25	19	15	200	250	10	*1

*1 C-Ring=1301C, Pin/O-Ring=1301A/B → P250-251

NV13145-100/-150/-200



Extended Sockets
Schaftsteckschlüssel
Douilles rallongées

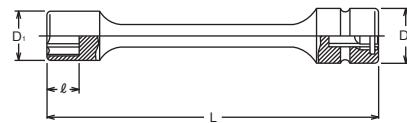

NV13760-75P/-125P/-150P/-250P

Extension Bars
Verlängerungen
Rallonges

NV13760	D (mm)	L (mm)	(g)	(pcs.)	⚡
75P	19	75	95	10	*1
125P	19	125	125	10	*1
150P	19	150	150	10	*1
250P	19	250	255	10	*1

*1 C-Ring=1301C, Pin/O-Ring=1301A/B → P250-251

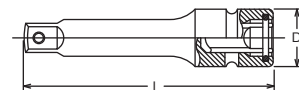

3/8", 1/2"

Z-SERIES
HAND
TITANIUM
SCREWDRIVERS ACCESSORIES
IMPACT
SLEEVE-DRIVE
PROTECTOR
INDUSTRIAL
AUTOMOTIVE
MOTORCYCLE
CONSTRUCTION
SPARE PART

183H-35/-75/-150

Hex Bits
Sechskant Bits
Embouts, 6 pans creux

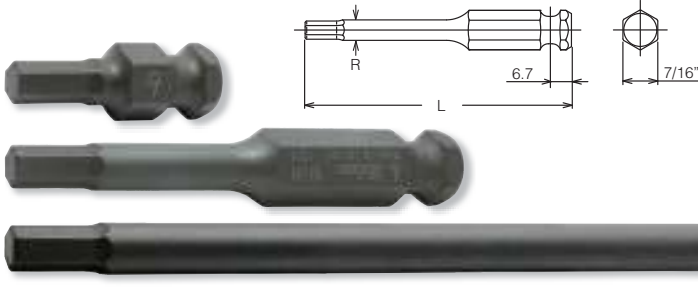

	183H-35 (inch)	L (mm)	(g)	(pcs.)
New	3/16	35	15	10
New	7/32	35	16	10
New	1/4	35	18	10
New	5/16	35	20	10
New	3/8	35	26	10
New	7/16	35	28	10
New	1/2	35	38	10

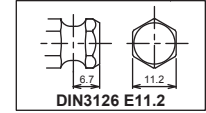

	183H-35 (mm)	L (mm)	(g)	(pcs.)
	3	35	15	10
	4	35	15	10
	5	35	15	10
	6	35	18	10
New	7	35	19	10
	8	35	20	10
	10	35	26	10
New	11	35	28	10
	12	35	30	10
	14	35	35	10
New	16	35	47	10
New	17	35	50	10
New	18	35	53	10
New	19	35	56	10

	183H-75 (mm)	L (mm)	R (mm)	(g)	(pcs.)
	3	75	6.0	34	10
	4	75	6.0	35	10
	5	75	6.5	36	10
	6	75	7.5	39	10
New	7	75	8.5	44	10
	8	75	9.5	47	10
	10	75	-	57	10
New	11	75	-	60	10
	12	75	-	65	10
	14	75	-	79	10

	183H-150 (mm)	L (mm)	R (mm)	(g)	(pcs.)
	4	150	6.0	51	10
	5	150	6.5	55	10
	6	150	7.5	65	10
	8	150	9.5	87	10
	10	150	-	118	10
	12	150	-	136	10

183T-35/-75/-150 (T)

TORX® Bits
TORX® Bits
Embouts, TORX®

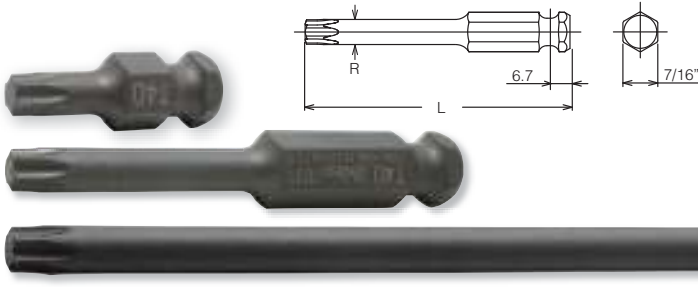

	183T-35 (T)	L (mm)	(g)	(pcs.)
New	T25	35	18	10
	T30	35	18	10
	T40	35	20	10
	T45	35	22	10
	T50	35	26	10
	T55	35	30	10
	T60	35	38	10

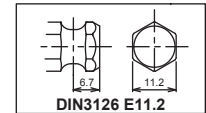

	183T-150 (T)	L (mm)	R (mm)	(g)	(pcs.)
	T30	150	6.0	50	10
	T40	150	6.9	58	10
	T45	150	8.0	70	10
	T50	150	9.0	82	10
	T55	150	11.4	113	10

	183T-75 (T)	L (mm)	R (mm)	(g)	(pcs.)
	T30	75	6.0	35	10
	T40	75	6.9	37	10
	T45	75	8.0	41	10
	T50	75	9.0	45	10
	T55	75	11.4	55	10
	T60	75	13.5	67	10

183T-35/-75 (IP)

TORXPLUS® Bits
TORXPLUS® Bits
Embouts TORXPLUS®

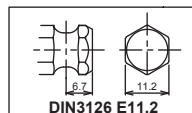
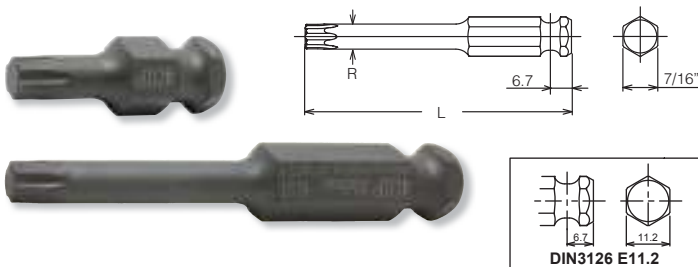

	183T-35 (IP)	L (mm)	(g)	(pcs.)
	30IP	35	18	10
	40IP	35	20	10
	45IP	35	22	10
	50IP	35	26	10
	55IP	35	30	10
	60IP	35	38	10

	183T-75 (IP)	L (mm)	R (mm)	(g)	(pcs.)
	30IP	75	6.0	35	10
	40IP	75	6.8	37	10
	45IP	75	8.0	41	10
	50IP	75	9.0	45	10
	55IP	75	11.4	56	10
	60IP	75	13.5	67	10

TORX® is a registered trademark of Acument Intellectual Properties, LLC.
TORX® ist ein registriertes Markenzeichen der Firma Acument Intellectual Properties, LLC.
TORX® est une marque déposée de Acument Intellectual Properties, LLC.

TORXplus® is a registered trademark of Acument Intellectual Properties, LLC.
TORXplus® ist ein registriertes Markenzeichen der Firma Acument Intellectual Properties, LLC.
TORXplus® est une marque déposée de Acument Intellectual Properties, LLC.

3/8", 1/2"

Sleeve-Drive Sockets
Sleeve-Drive Steckschlüssel
Douilles, Sleeve Drive

Z-SERIES
HAND
TITANIUM
ACCESSORIES
SCREWDRIVERS
IMPACT
SLEEVE-DRIVE
PROTECTOR
INDUSTRIAL
AUTOMOTIVE
MOTORCYCLE
CONSTRUCTION
SPARE PART

183X-35/-75/-150 (XZN)



XZN Bits
XZN Bits
Embouts, XZN

183X-35 (XZN)	L (mm)	(g)	(pcs.)
M 4	35	18	10
M 5	35	18	10
M 6	35	20	10
M 8	35	22	10
M10	35	26	10
M12	35	30	10
M14	35	38	10

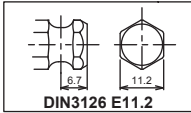
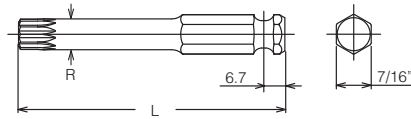

183X-75 (XZN)	L (mm)	R (mm)	(g)	(pcs.)
M 4	75	6.0	34	10
M 5	75	6.0	34	10
M 6	75	6.2	36	10
M 8	75	7.4	39	10
M10	75	9.8	54	10
M12	75	11.7	57	10
M14	75	13.5	67	10

183X-150 (XZN)	L (mm)	R (mm)	(g)	(pcs.)
M 5	150	6.0	50	10
M 6	150	6.2	53	10
M 8	150	7.4	64	10
M10	150	9.8	93	10
M12	150	11.7	121	10

	D ₁ (mm)	D ₂ (mm)	ℓ (mm)	L (mm)	(g)	(pcs.)	
NV13134	22.5	22	15	45	100	5	*1

*1 C-Ring=1301C, Pin/O-Ring=1301A/B → P250-251

For DIN3126 E11.2 Bits
Für DIN3126 E11.2 Bits
Pour DIN3126 E11.2 Embouts

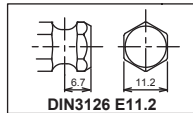

13134-SC

Replacement Screw : M8x5 ● 4mm



NV13134



Bit Holder
Klinghalter
Porte-embouts

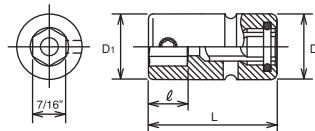

	D ₁ (mm)	D ₂ (mm)	ℓ (mm)	L (mm)	(g)	(pcs.)	
NV14134	22.5	25	15	55	130	5	*1

*1 C-Ring=1401C, Pin/O-Ring=1401A/B → P250-251

For DIN3126 E11.2 Bits
Für DIN3126 E11.2 Bits
Pour DIN3126 E11.2 Embouts

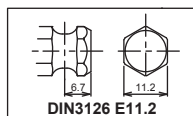

13134-SC

Replacement Screw : M8x5 ● 4mm



NV14134



Bit Holder
Klinghalter
Porte-embouts

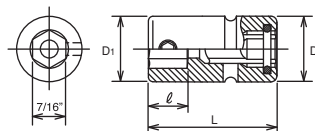

Sleeve-Drive Sockets

Sleeve-Drive Steckschlüssel

Douilles, Sleeve Drive

1/2"

Z-SERIES
HAND
TITANIUM
SCREWDRIVERS ACCESSORIES
IMPACT
SLEEVE-DRIVE
PROTECTOR
INDUSTRIAL
AUTOMOTIVE
MOTORCYCLE
CONSTRUCTION
SPARE PART

NV14400

6-point Sockets
6-kant Steckschlüssel
Douilles 6-pans

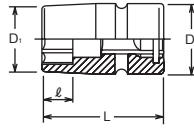

NV14400 (mm)	D ₁ (mm)	D ₂ (mm)	ℓ (mm)	L (mm)	(g)	(pcs.)	⚡
12	19.5	25	9	54	120	10	*1
13	20.7	25	10	54	120	10	*1
14	22	25	10	54	120	10	*1
15	23.2	30	11	54	188	10	*2
16	24.5	30	11	54	189	10	*2
17	25.7	30	12	54	190	10	*2
18	27	30	12	54	190	10	*2
19	28.2	30	12	54	190	10	*2
21	30.7	30	12	54	191	10	*2
22	32	30	12	54	192	10	*2
23	33.2	30	12	54	196	10	*2
24	34.5	30	12	54	200	10	*2

*1 C-Ring=1401C, Pin/O-Ring=1401A/B → P250-251
*2 C-Ring=1402C, Pin/O-Ring=1402A/B

NV14145-100/-150/-200

Extended Sockets
Schafftsteckschlüssel
Douilles rallongées

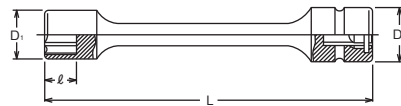

NV14145-100 (mm)	D ₁ (mm)	D ₂ (mm)	ℓ (mm)	L (mm)	(g)	(pcs.)	⚡
10	15.5	25	10	100	161	1	*1
12	18	25	12	100	178	1	*1
13	19	25	13	100	175	1	*1
14	21	25	14	100	181	1	*1
15	22	25	15	100	185	1	*1
16	24	25	15	100	193	1	*1
17	25	25	15	100	201	1	*1
18	26	25	15	100	211	1	*1
19	28	25	15	100	221	1	*1

NV14145-150 (mm)	D ₁ (mm)	D ₂ (mm)	ℓ (mm)	L (mm)	(g)	(pcs.)	⚡
10	15.5	25	10	150	200	1	*1
12	18	25	12	150	215	1	*1
13	19	25	13	150	220	1	*1
14	21	25	14	150	225	1	*1
15	22	25	15	150	230	1	*1
16	24	25	15	150	240	1	*1
17	25	25	15	150	250	1	*1
18	26	25	15	150	262	1	*1
19	28	25	15	150	275	1	*1

NV14145-200 (mm)	D ₁ (mm)	D ₂ (mm)	ℓ (mm)	L (mm)	(g)	(pcs.)	⚡
10	15.5	25	10	200	236	1	*1
12	18	25	12	200	250	1	*1
13	19	25	13	200	260	1	*1
14	21	25	14	200	270	1	*1
15	22	25	15	200	275	1	*1
16	24	25	15	200	287	1	*1
17	25	25	15	200	300	1	*1
18	26	25	15	200	310	1	*1
19	28	25	15	200	320	1	*1

*1 C-Ring=1401C, Pin/O-Ring=1401A/B → P250-251

NV14760-75P/-125P/-175P/-250P

Extension Bars
Verlängerungen
Rallonges

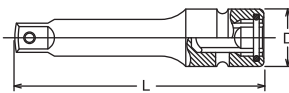

NV14760	D (mm)	L (mm)	(g)	(pcs.)	⚡
75P	25	75	149	10	*1
125P	25	125	230	10	*1
175P	25	175	308	10	*1
250P	25	250	422	10	*1

*1 C-Ring=1401C, Pin/O-Ring=1401A/B → P250-251

NV14433A-75P/-100P/-150P

Adaptors
Verbindungsstücke
Réducteurs

No Warranty
Keine Garantie
Sans Garantie

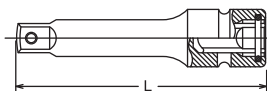

NV14433A	(mm)	(mm)	L (mm)	(g)	(pcs.)	⚡
75P	1/2"	3/8"	75	120	1	*1
100P	1/2"	3/8"	100	145	1	*1
150P	1/2"	3/8"	150	187	1	*1

*1 C-Ring=1401C, Pin/O-Ring=1401A/B → P250-251

⚠ Adapting down from bigger square drive to smaller square drive may lead to excessive torque load and possibly cause breakage. Always stay within safe torque of the smaller square drive.

Die mit ⚠ gekennzeichneten Artikel können bei Überbelastung zu Bruch gehen. Aus Gründen Ihrer eigenen Sicherheit sollten die betreffenden Werkzeuge nie ruckartig, sondern nach und nach belastet werden, um Bruch und damit verbundene mögliche Verletzungen zu vermeiden.

Il est possible d'appliquer aux articles marqués ⚠ des couples de serrage susceptibles d'occasionner leur rupture. Pour votre propre sécurité, veuillez toujours appliquer la charge d'une manière uniforme et progressive. Ceci pour éviter ruptures et accidents.

3/4"

Sleeve-Drive Sockets
Sleeve-Drive Steckschlüssel
Douilles, Sleeve Drive

NV16400 (mm)	D ₁ (mm)	D ₂ (mm)	ℓ (mm)	L (mm)	(g)	(pcs.)	⚡
17	30	44	12	65	448	5	*1
18	31.3	44	13	65	470	5	*1
19	32.5	44	13	65	455	5	*1
21	35	44	15	65	472	5	*1
22	36.3	44	16	65	471	5	*1
23	37.5	44	16	65	471	5	*1
24	38.8	44	16	65	467	5	*1
26	41.3	44	16	65	477	5	*1
27	42.5	44	16	65	473	5	*1
28	43.8	44	16	68	483	5	*1
29	45	44	18	68	464	5	*1
30	46.3	44	18	68	492	5	*1
32	48.8	44	19	70	514	5	*1
33	50	44	20	70	564	5	*1
34	51.3	44	20	70	588	5	*1
35	52.5	44	20	70	593	5	*1
36	53.8	44	20	70	598	5	*1
38	56.3	44	20	72	670	2	*1
41	60	44	22	72	687	2	*1
46	66.3	44	23	77	906	2	*1
50	69	44	23	77	1116	2	*1

*1 C-Ring=1600C, Pin/O-Ring=1601A/B → P250-251

NV16400  6-point Sockets
6-kant Steckschlüssel
Douilles 6-pans

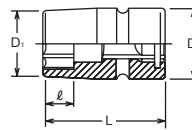

NV16760-175/-250/-330 Extension Bars
Verlängerungen
Rallonges



NV16760	D (mm)	L (mm)	(g)	(pce.)	⚡
175	44	175	870	1	*1
250	44	250	1160	1	*1
330	44	330	1460	1	*1

*1 C-Ring=1600C, Pin/O-Ring=1601A/B → P250-251

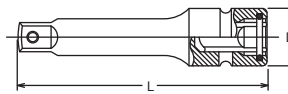

Z-SERIES
HAND
TITANIUM
ACCESSORIES
SCREWDRIVERS
IMPACT
SLEEVE-DRIVE
PROTECTOR
INDUSTRIAL
AUTOMOTIVE
MOTORCYCLE
CONSTRUCTION
SPARE PART

C-Ring Lock Clamps and Pullers
Sicherungsklemmen und Abzieher
Crochets de sécurité et extracteurs

Z-SERIES
HAND
TITANIUM
ACCESSORIES
IMPACT
SLEEVE-DRIVE
PROTECTOR
INDUSTRIAL
AUTOMOTIVE
MOTORCYCLE
CONSTRUCTION
SPARE PART



One Piece solid springs steel ring. Simply set by finger pushing and easily removed by puller. Much more convenient and safer than combination of pin and o-ring.

Aus starkem Federstahl, in einem Stück. Bequem, mit einem Fingerdruck einzusetzen und mit dem Auszieher zu lösen. Einfacher und sicherer als die Kombination Stift und Ring.

Acier à ressorts, en une pièce. Mise en place d'une simple pression du pouce, enlèvement au moyen de la griffe d'extraction. Beaucoup plus facile et sûr que la combinaison goupille/bague.

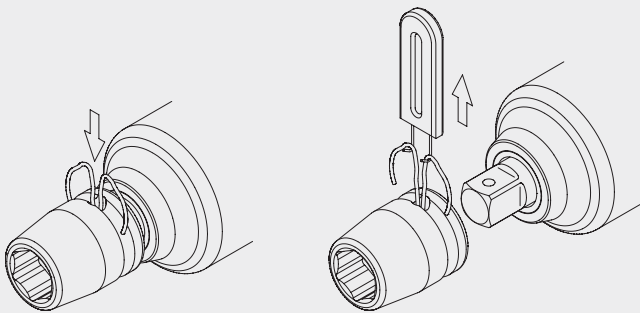

C-Ring

No.	Opening (mm)	Opening (mm)	(pcs.)
1301C	3/8"	≤ 12	100
1302C	3/8"	> 12	100
1401C	1/2"	≤ 14	100
1402C	1/2"	> 14	100
1600C	3/4"	≤ 46	100
1801C	1"	≤ 70	100
1802C	1"	> 70	50
1700C	1-1/2"	≤ 90	50

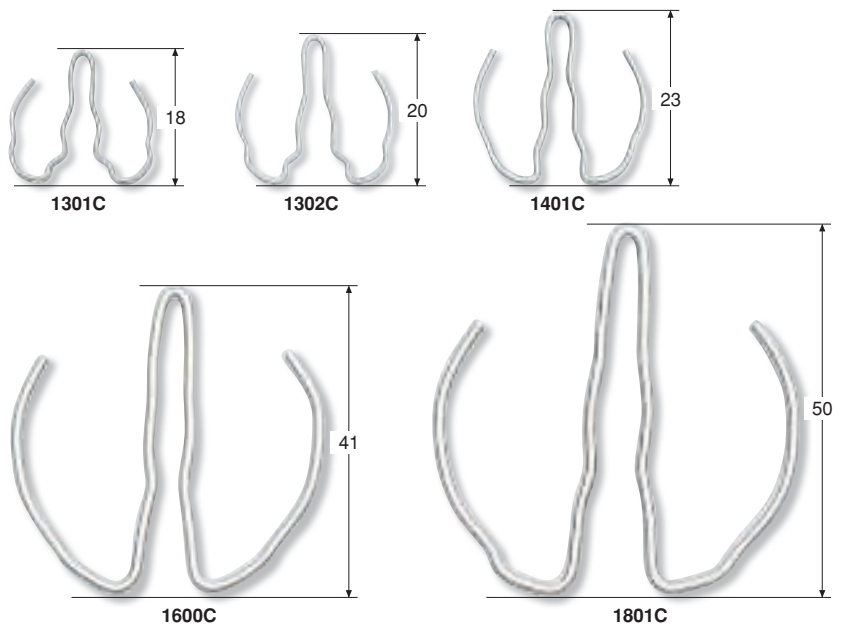

C-Ring Set

Set No.	C-Ring 10pcs.	Puller 1pce.
PK1301C	1301C + 149	
PK1302C	1302C + 149	
PK1401C	1401C + 149	
PK1402C	1402C + 149	
PK1600C	1600C + 152	
PK1801C	1801C + 152	

Puller

No.	Opening (mm)	(pcs.)
149	3/8" 1/2"	10
152	3/4" 1"	10



149



152

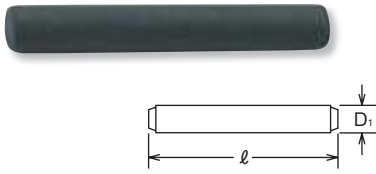

Pin

No.	□	Opening (mm)	D ₁ (mm)	ℓ (mm)	pcs.
1200A	1/4"		1.5	10.2	100
1301A	3/8"	≤ 12	2.5	14.5	100
1302A	3/8"	> 12	2.5	17.5	100
1401A	1/2"	≤ 14	3.5	20	100
1402A	1/2"	> 14	3.5	25	100
1500A	5/8"		4	29	100
1601A	3/4"	≤ 46	5.5	35	100
1602A	3/4"	> 46	5.5	45	100
1801A	1"	≤ 70	6	45	100
1802A	1"	> 70	6	75	50
1701A	1-1/2"	≤ 90	7	75	50
1702A	1-1/2"	> 90	7	110	50
1901A	2-1/2"	≤ 115	9	110	50
1902A	2-1/2"	> 115	9	155	50
2001A	3-1/2"	≤ 140	13	155	1
2002A	3-1/2"	> 140	13	180	1



O-Ring

No.	□	Opening (mm)	D ₂ (mm)	D ₃ (mm)	pcs.
1200B	1/4"		2.5	9	100
1301B	3/8"	≤ 12	3.5	13	100
1302B	3/8"	> 12	3.5	16	100
1401B	1/2"	≤ 14	4	19	100
1402B	1/2"	> 14	4	24	100
1500B	5/8"		5	28	100
1601B	3/4"	≤ 46	5	36	100
1602B	3/4"	> 46	5	45	100
1801B	1"	≤ 70	7	45	100
1802B	1"	> 70	7	75	50
1701B	1-1/2"	≤ 90	10	75	50
1702B	1-1/2"	> 90	10	114	50
1901B	2-1/2"	≤ 115	10.5	114	50
1902B	2-1/2"	> 115	10.5	158	50
2001B	3-1/2"	≤ 140	15	158	1
2002B	3-1/2"	> 140	15	183	1



Pins & O Rings/C-Ring Lock Clamps
 Halteringe und Stifte/Sicherungsklemmen
 Goupilles et joncs/Crochets de sécurité

Z-SERIES
 HAND
 TITANIUM
 SCREWDRIVERS
 ACCESSORIES
 IMPACT
 SLEEVE-DRIVE
 PROTECTOR
 INDUSTRIAL
 AUTOMOTIVE
 MOTORCYCLE
 CONSTRUCTION
 SPARE PART

IMPACT Standard Sockets	Sq. Dr.	1/4"	3/8"		1/2"		3/4"		1"		1-1/2"		
		C-Ring	1301C	1302C	1401C	1402C	1600C	1801C	1801C	1802C	1700C		
		O-Ring/Pin	1200A/B	1301A/B	1302A/B	1401A/B	1402A/B	1601A/B	1602A/B	1801A/B	1802A/B	1701A/B	1702A/B
4		●											
4.5	3/16	●											
5		●											
5.5		●											
6	1/4	●	●										
7	9/32	●	●										
8	5/16	●	●		●								
9	11/32	●	●		●								
10	3/8	●	●		●								
11	7/16	●	●		●								
12		●	●		●								
13	1/2	●		●	●								
14	9/16	●		●	●								
15				●	●	●							
16	5/8			●	●	●	●		●				
17	11/16			●	●	●	●		●				
18				●	●	●	●		●				
19	3/4			●	●	●	●		●				
20				●	●	●	●		●				
21	13/16			●	●	●	●		●				
22	7/8			●	●	●	●		●				
23				●	●	●	●		●				
24	15/16			●	●	●	●		●				
25	1				●	●	●		●				
26					●	●	●		●				
27	1- 1/16				●	●	●		●				
28					●	●	●		●				
29	1- 1/8				●	●	●		●				
30	1- 3/16				●	●	●		●				
31					●	●	●		●				
32	1- 1/4				●	●	●		●				
33	1- 5/16				●	●	●		●				
34	1- 3/8				●	●	●		●				
36					●	●	●		●				
37	1- 7/16						●		●				
38	1- 1/2						●		●				
39							●		●				
40	1- 9/16						●		●				
41	1- 5/8						●		●				
42							●		●		●		
43	1- 11/16						●		●		●		
44							●		●		●		
45	1- 3/4						●		●		●		
46	1- 13/16						●		●		●		
47							●		●		●		
48	1- 7/8						●		●		●		
	1- 15/16						●		●		●		
50							●		●		●		
	2						●		●		●		
52	2- 1/16						●		●		●		
54	2- 1/8						●		●		●		
55	2- 3/16						●		●		●		
56							●		●		●		
	2- 1/4						●		●		●		
58	2- 5/16						●		●		●		
60	2- 3/8						●		●		●		
62	2- 7/16						●		●		●		
63							●		●		●		
	2- 1/2						●		●		●		
65	2- 9/16						●		●		●		
67	2- 5/8						●		●		●		
68	2- 11/16						●		●		●		
70	2- 3/4						●		●		●		
	2- 13/16						●		●		●		
	2- 7/8						●		●		●		
75	2- 15/16						●		●		●		
	3						●		●		●		
	3- 1/16						●		●		●		
80	3- 1/8						●		●		●		
	3- 1/4						●		●		●		
85							●		●		●		
	3- 3/8						●		●		●		
90	3- 1/2						●		●		●		
	3- 5/8						●		●		●		
95	3- 3/4						●		●		●		
100	3- 7/8						●		●		●		
105	4						●		●		●	●	
	4- 1/8						●		●		●	●	
110	4- 1/4						●		●		●	●	
115	4- 1/2						●		●		●	●	
120	4- 5/8						●		●		●	●	
	4- 3/4						●		●		●	●	
125	4- 7/8						●		●		●	●	
130	5						●		●		●	●	
135	5- 1/4						●		●		●	●	
140							●		●		●	●	
150							●		●		●	●	
	6						●		●		●	●	
	6- 1/2						●		●		●	●	

SOCKETS WITH TURNABLE PLASTIC PROTECTORS
STECKSCHLÜSSEL MIT DREHBAREN SCHUTZHÜLSEN AUS KUNSTSTOFF
DOUILLES A PROTECTIONS PLASTIFIEES





Safety

Turnable plastic protector increases operator's safety during assembly process.

Unsere drehbaren Kunststoff-Hülsen erhöhen die Arbeitssicherheit während des Montageprozesses.

Nos protections rotatives plastifiées augmentent la sécurité lors du montage.



Scratch proof

Protector helps to reduce the possibility giving damage on painted, polished and sensitive surfaces. Protector is free rotation designed.

Die Protektoren vermeiden Beschädigungen an lackierten-, polierten- bzw. empfindlichen Oberflächen. Unsere Protektoren sind frei drehbar.

Les protections évitent des endommagements sur des surfaces laquées, polies ou sensibles. Nos protections ont une libre rotation.

Our Protector series is make-to-order manufacturing.
Die Kunststoffhülsen werden in Einzelfertigung hergestellt.
Les protections plastifiées sont fabriquées individuellement .

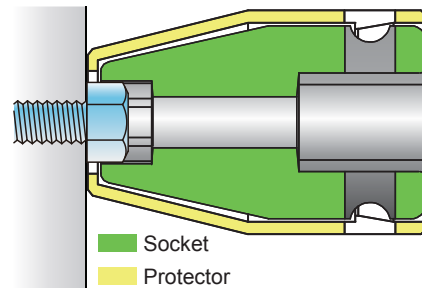

3/8" 1/2"

Protector
Hülsen
Protections

13400M (FR)	D ₁ (mm)	D ₂ (mm)	ℓ (mm)	L (mm)	(g)
8FR	15.7	22	6	33.3	40
10FR	18.2	22	7	33.3	40
12FR	20.8	22	9	33.3	43
13FR	21.8	25	10	33.3	56
14FR	23.6	25	10	33.3	56
16FR	26.1	25	11	33.3	57
17FR	27.3	25	12	33.3	60

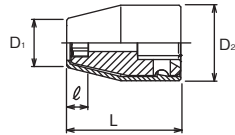

13400M-FR

6-point Sockets
6-kant Steckschlüssel
Douilles 6-pans



13760 (FR)	D (mm)	L (mm)	(g)
125P.FR	26.2	125	145
250P.FR	26.2	250	220

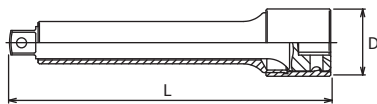

13760-125P.FR/-250P.FR

Extension Bars
Verlängerungen
Rallonges



14400M (FR)	D ₁ (mm)	D ₂ (mm)	ℓ (mm)	L (mm)	(g)
10FR	19.5	28	7	39.3	90
12FR	22	28	9	39.3	90
13FR	23.2	28	10	39.3	90
14FR	24.8	28	11	39.3	90
16FR	27	33	10	39.3	135
17FR	28.2	33	12	39.3	135
19FR	31	33	13	39.3	130

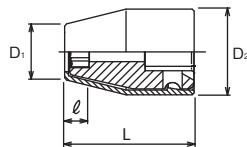

14400M-FR

6-point Sockets
6-kant Steckschlüssel
Douilles 6-pans



14760 (FR)	D (mm)	L (mm)	(g)
125P.FR	34.2	125	280
250P.FR	34.2	250	480

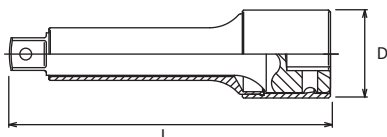

14760-125P.FR/-250P.FR

Extension Bars
Verlängerungen
Rallonges



Z-SERIES
HAND
TITANIUM
ACCESSORIES
SCREWDRIVERS
IMPACT
SLEEVE-DRIVE
PROTECTOR
INDUSTRIAL
AUTOMOTIVE
MOTORCYCLE
CONSTRUCTION
SPARE PART

113-75SV/-100SV/-150SV



Nut Setters
Steckschlüssel Klingen
Emboutis pour écrous

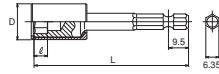

113-150 (SV)	D (mm)	ℓ (mm)	L (mm)	(g)
8SV	15.1	6	150	62
10SV	16.9	7	150	66
12SV	19.4	8	150	72
13SV	20.4	8	150	80

113-75 (SV)	D (mm)	ℓ (mm)	L (mm)	(g)
8SV	15.1	6	75	34
10SV	16.9	7	75	37
12SV	19.4	8	75	44
13SV	20.4	8	75	45

113-100 (SV)	D (mm)	ℓ (mm)	L (mm)	(g)
8SV	15.1	6	100	43
10SV	16.9	7	100	47
12SV	19.4	8	100	54
13SV	20.4	8	100	55

115-75SV/-100SV/-150SV



Nut Setters with Magnet
Steckschlüssel Klingen mit Magnet
Emboutis avec aimant pour écrous

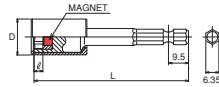

115-150 (SV)	D (mm)	ℓ (mm)	L (mm)	(g)
8SV	15.1	3.5	150	63
10SV	16.9	4.2	150	70
12SV	19.4	5.6	150	79
13SV	20.4	6	150	87



115-75 (SV)	D (mm)	ℓ (mm)	L (mm)	(g)
8SV	15.1	3.5	75	35
10SV	16.9	4.2	75	40
12SV	19.4	5.6	75	48
13SV	20.4	6	75	54

115-100 (SV)	D (mm)	ℓ (mm)	L (mm)	(g)
8SV	15.1	3.5	100	44
10SV	16.9	4.2	100	52
12SV	19.4	5.6	100	60
13SV	20.4	6	100	67

115G-100FR/-150FR/-200FR



Nut Setters with sliding Magnet
Steckschlüssel Klingen mit versenkbarem Magnet
Emboutis avec aimant, glissant pour écrous

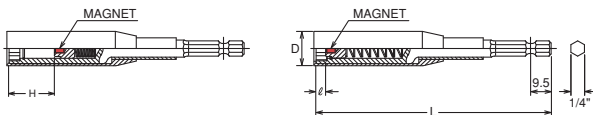

115G-200 (FR)	D (mm)	ℓ (mm)	H (mm)	L (mm)	(g)
8FR	15.1	4	26	200	90
10FR	16.9	4.5	26	200	100
12FR	19.3	6	26	200	125
13FR	20.4	6.5	25	200	135



115G-100 (FR)	D (mm)	ℓ (mm)	H (mm)	L (mm)	(g)
8FR	15.1	4	26	100	55
10FR	16.9	4.5	26	100	60
12FR	19.3	6	26	100	80
13FR	20.4	6.5	25	100	85

115G-150 (FR)	D (mm)	ℓ (mm)	H (mm)	L (mm)	(g)
8FR	15.1	4	26	150	75
10FR	16.9	4.5	26	150	80
12FR	19.3	6	26	150	100
13FR	20.4	6.5	25	150	110

REPLACEMENT

Remove a damaged Protector and put a new Protector on socket / Extension bar by pressing. For your safety, worn out or cracked Protector must be replaced.

AUSTAUSCH

Entfernen Sie defekte Protektoren und ersetzen Sie diese auf Ihrem Steckschlüssel/Verlängerung mittels einer Presse. Bitte tauschen Sie zu Ihrer Sicherheit verschlissene Protektoren aus !

REPLACEMENT

Retirez les protections défectueuses, remplacez celles-ci et fixez-les sur les douilles/rallonges à l'aide d'une presse. Pour votre sécurité remplacez toute protection défectueuse.



Specifications or design of any product in this catalogue are subject to change without notice.

Wir behalten uns das Recht vor, jedes in diesem Katalog gezeigte Werkzeug, auch ohne vorherige Ankündigung, in Ausführung und Design ändern zu dürfen.

Nous nous réservons le droit de modifier les modèles et les dimensions des outils présentés dans ce catalogue et ce sans autre notification préalable.

INDUSTRIAL SOCKETS

STECKSCHLÜSSEL, INDUSTRIE-AUSFÜHRUNG
CLES A DOUILLES, FINISSAGE INDUSTRIEL

1/4"

3/8"

1/2"



Industrial Sockets
Steckschlüssel, Industrie-Ausführung
Clés à douilles, finissage industriel **1/4"**

Z-SERIES
HAND
TITANIUM
ACCESSORIES
SCREWDRIVERS
IMPACT
SLEEVE-DRIVE
PROTECTOR
INDUSTRIAL
AUTOMOTIVE
MOTORCYCLE
CONSTRUCTION
SPARE PART

22400M  6-point Sockets
6-kant Steckschlüssel
Douilles 6-pans

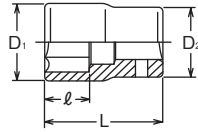

22400M (mm)	D ₁ (mm)	D ₂ (mm)	ℓ (mm)	L (mm)	(g)	(pcs.)
6	9.2	11.2	5.5	22	9	10
7	10.3	11.2	6	22	9	10
8	11.2	11.7	6.9	22	11	10
10	14.3	12.9	7.7	22	15	10
12	16.8	15.5	9.3	22	23	10
13	18	16.4	9.8	22	23	10

22425  TORX® Sockets
TORX® Steckschlüssel
Douilles TORX®

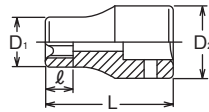

22425 (E)	D ₁ (mm)	D ₂ (mm)	ℓ (mm)	L (mm)	(g)	(pcs.)
E 4	5.4	11.2	4.6	22	7	10
E 5	6.7	11.2	5.2	22	8	10
E 6	7.7	11.2	5.4	22	8	10
E 7	8.3	11.2	6.6	22	9	10
E 8	9.6	11.2	7	22	9	10
E10	11.3	12	8.2	22	10	10

TORX® (E)

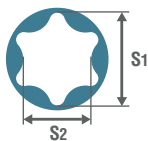

E	E4	E5	E6	E7	E8	E10	E11	E12	E14	E16	E18	E20	E22	E24	E26	E28
S ₁ (ref. mm)	3.7	4.6	5.6	6.1	7.4	9.3	9.9	11.0	12.8	14.6	16.5	18.3	20.1	22.0	23.7	25.5
S ₂ (ref. mm)	2.7	3.3	4.0	4.3	5.3	6.8	7.1	7.9	9.2	10.5	11.9	13.2	14.8	15.7	17.5	18.3

22300M / 22300A  6-point Sockets, deep
6-kant Steckschlüssel, lang
Douilles longues, 6-pans

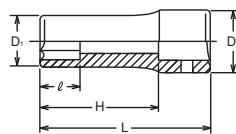

22300M (mm)	D ₁ (mm)	D ₂ (mm)	ℓ (mm)	H (mm)	L (mm)	(g)	(pcs.)
7	10.3	11.2	8	40	50	24	10
8	11.2	11.7	9	40	50	28	10
10	14.3	12.9	11	39	50	33	10
12	16.8	15.5	13	39	50	50	10
13	18	16.4	14	39	50	50	10

22300A (inch)	D ₁ (mm)	D ₂ (mm)	ℓ (mm)	H (mm)	L (mm)	(g)	(pcs.)
1/4	9.6	11.2	7	40	50	24	10
5/16	11.2	11.7	9	40	50	28	10
3/8	13.7	12.5	11	40	50	33	10

Industrial sockets are thin walled sockets to be used on electric or pneumatic nut runners for assembly work only.

Bei den Industrial Steckschlüsseln handelt es sich um dünnwandige Werkzeuge, die ausschliesslich auf pneumatischen und elektrischen Drehschraubern (nicht schlagend) verwendet werden dürfen.

Les douilles Industrielles à paroi mince ne doivent être utilisées que sur des vis à fixer par visseuses (non-chocs).

Z-SERIES
HAND
TITANIUM
ACCESSORIES
SCREWDRIVERS
IMPACT
SLEEVE-DRIVE
PROTECTOR
INDUSTRIAL
AUTOMOTIVE
MOTORCYCLE
CONSTRUCTION
SPARE PART

23400M (mm)	D ₁ (mm)	D ₂ (mm)	ℓ (mm)	L (mm)	(g)	(pcs.)
6	9.9	17.3	6	26	20	10
7	10.8	17.3	6.5	26	20	10
8	12	17.3	6.9	26	22	10
10	14.5	17.3	8	26	24	10
11	15.8	17.3	9.3	26	25	10
12	16.8	17.3	9	26	25	10
13	18	17	9.4	26	24	10
14	19.5	18.5	11	27	31	10
15	21	19.5	11.5	28	39	10
16	22	20	12	28	42	10
17	23.5	21.5	12.5	29	51	10
18	24.6	22.5	13	30	51	10
19	26	23.5	13.5	30	53	10
21	28	26	14.5	32	77	10

23400A (inch)	D ₁ (mm)	D ₂ (mm)	ℓ (mm)	L (mm)	(g)	(pcs.)
5/16	12	17.3	6.9	26	22	10
3/8	13.9	17.3	8	26	22	10
7/16	15.8	17.3	9.3	26	25	10
1/2	18	17	9.4	26	24	10
9/16	19.5	18.5	11	27	31	10
11/16	24.6	22.5	13	30	51	10
3/4	26	23.5	13.5	30	63	10

23405M (mm)	D ₁ (mm)	D ₂ (mm)	ℓ (mm)	L (mm)	(g)	(pcs.)
8	12	17.3	6.9	26	22	10
10	14.5	17.3	8	26	24	10
12	16.8	17.3	9	26	25	10
14	19.5	18.5	11	27	31	10

23410M (mm)	D ₁ (mm)	D ₂ (mm)	ℓ (mm)	L (mm)	(g)	(pcs.)
8	12	17.3	6.9	26	22	10
10	14.5	17.3	8	26	24	10
12	16.8	17.3	9	26	25	10
13	18	17	9.4	26	24	10
14	19.5	18.5	11	27	31	10
15	21	19.5	11.5	28	39	10
16	22	20	12	28	42	10
17	23.5	21.5	12.5	29	51	10
18	24.6	22.5	13	30	51	10
19	26	23.5	13.5	30	53	10

23425 (E)	D ₁ (mm)	D ₂ (mm)	ℓ (mm)	L (mm)	(g)	(pcs.)
E 5	7	17.3	5.2	26	20	10
E 6	8.3	17.3	5.4	26	21	10
E 7	8.9	17.3	6.6	26	22	10
E 8	9.9	17.3	7	26	23	10
E10	12	17.3	8.2	26	24	10
E11	13.3	17.3	8.7	26	25	10
E12	14.5	17.3	9.3	26	26	10
E14	15.8	17.3	10.6	26	27	10
E16	18	17	11.8	26	27	10

23400M / 23400A 6-point Sockets 6-kant Steckschlüssel Douilles 6-pans

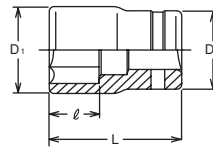

23405M 12-point Sockets 12-kant Steckschlüssel Douilles 12-pans

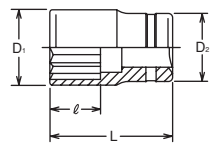

23410M Surface Drive Sockets Surface Drive Steckschlüssel Douilles, Surface Drive

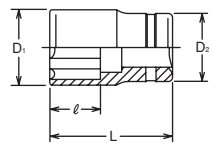

23425 TORX® Sockets TORX® Steckschlüssel Douilles TORX®

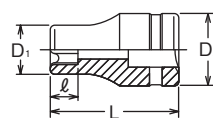

Industrial Sockets

Steckschlüssel, Industrie-Ausführung

Clés à douilles, finissage industriel

3/8"

Z-SERIES
HAND
TITANIUM
SCREWDRIVERS ACCESSORIES
IMPACT
SLEEVE-DRIVE
PROTECTOR
INDUSTRIAL
AUTOMOTIVE
MOTORCYCLE
CONSTRUCTION
SPARE PART

23300M / 23300A

6-point Sockets, deep
6-kant Steckschlüssel, lang
Douilles longues, 6-pans

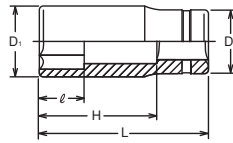

23300M (mm)	D ₁ (mm)	D ₂ (mm)	ℓ (mm)	H (mm)	L (mm)	(g)	(pcs.)
7	10.6	17.4	8	41.5	55	40	10
8	12	17.4	9	41.5	55	45	10
10	14.5	17.4	11	41.5	55	52	10
11	16	17.2	12	41.5	55	55	10
12	16.8	17.2	13	41.5	55	58	10
13	18	17	14	41.5	55	57	10
14	20	18	16	41.5	55	68	10
15	21	20	16	40.5	55	78	10
16	22	20	17	40.5	55	79	10
17	23.5	22	18	40.5	55	96	10
18	24.5	23	19	39.5	55	96	10
19	25	24	20	39.5	55	102	10

23300A (inch)	D ₁ (mm)	D ₂ (mm)	ℓ (mm)	H (mm)	L (mm)	(g)	(pcs.)
5/16	12	17.4	9	41.5	55	45	10
3/8	14	17.4	11	41.5	55	51	10
7/16	16	17.2	12	41.5	55	55	10
1/2	18	17	14	41.5	55	57	10
9/16	20	18	16	41.5	55	68	10
11/16	23.5	22	18	40.5	55	96	10
3/4	25	24	20	39.5	55	102	10

23305M

12-point Deep Sockets
12-kant Steckschlüssel, lang
Douilles longues 12-pans

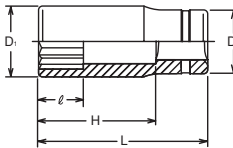

23305M (mm)	D ₁ (mm)	D ₂ (mm)	ℓ (mm)	H (mm)	L (mm)	(g)	(pcs.)
8	12	17.4	9	41.5	55	45	10
10	14.5	17.4	11	41.5	55	52	10
12	16.8	17.2	13	41.5	55	58	10
14	20	18	16	41.5	55	68	10

23310M

Surface Drive Sockets, deep
Surface Drive Steckschlüssel, lang
Douilles longues, Surface Drive

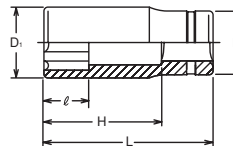

23310M (mm)	D ₁ (mm)	D ₂ (mm)	ℓ (mm)	H (mm)	L (mm)	(g)	(pcs.)
8	12	17.4	9	41.5	55	45	10
10	14.5	17.4	11	41.5	55	52	10
12	16.8	17.2	13	41.5	55	58	10
13	18	17	14	41.5	55	57	10
14	20	18	16	41.5	55	68	10
15	21	20	16	40.5	55	80	10
17	23.5	22	18	40.5	55	96	10

23325

TORX® Deep Sockets
TORX® Steckschlüssel, lang
Douilles longues TORX®

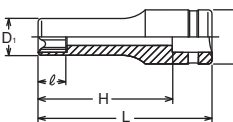

23325 (E)	D ₁ (mm)	D ₂ (mm)	ℓ (mm)	H (mm)	L (mm)	(g)	(pcs.)
E 5	6.9	17.4	5.2	41.5	55	50	10
E 6	7.9	17.4	5.4	41.5	55	52	10
E 7	8.9	17.4	6.6	41.5	55	55	10
E 8	9.9	17.4	7	41.5	55	58	10
E10	11.8	17.2	8.2	41.5	55	60	10
E12	14.5	17.2	9.3	41.5	55	68	10
E14	15.7	17.2	10.6	41.5	55	77	10
E16	18	17	11.8	41.5	55	80	10

23760-75P/-125P/-250P

Extension Bars
Verlängerungen
Rallonges

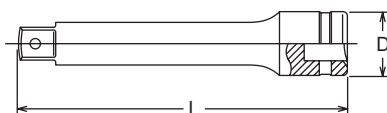

23760	D (mm)	L (mm)	(g)	(pcs.)
75P	18	75	70	10
125P	18	125	110	10
250P	18	250	200	5

1/2"

Industrial Sockets
Steckschlüssel, Industrie-Ausführung
Clés à douilles, finissage industriel

Z-SERIES
HAND
TITANIUM
ACCESSORIES
SCREWDRIVERS
IMPACT
SLEEVE-DRIVE
PROTECTOR
INDUSTRIAL
AUTOMOTIVE
MOTORCYCLE
CONSTRUCTION
SPARE PART

24400M (mm)	D ₁ (mm)	D ₂ (mm)	ℓ (mm)	L (mm)	(g)	(pcs.)
10	15.3	21	9	37	45	10
11	16.5	21	9.5	37	46	10
12	17.8	21	10	37	47	10
13	19	22	10.5	37	53	10
14	20.3	22	11	37	56	10
15	21.5	22	11.5	37	52	10
16	22.8	22	12	37	62	10
17	24.1	23	12.5	37	69	10
18	25.1	24	13	37	74	10
19	26.6	25	14	38	89	10
20	27.9	26	15	38	92	10
21	29.1	27	15.5	38	102	10
22	30.1	28	16	40	113	10
23	31.5	29	16.5	40	128	10
24	32.9	30	17	42	140	5
26	35	32	19	42	165	5
27	36.5	33	19.5	43	196	5
29	39	35	20.5	43	190	5
30	40	36	22	46	222	5
32	42.8	38	23	46	250	5

24400A (inch)	D ₁ (mm)	D ₂ (mm)	ℓ (mm)	L (mm)	(g)	(pcs.)
7/16	16.5	21	9.5	37	46	10
1/2	19	22	10.5	37	53	10
9/16	20.3	22	11	37	56	10
5/8	22.9	22	12	37	62	10
3/4	26.6	25	14	38	89	10
15/16	32.9	30	17	42	140	10

24405M (mm)	D ₁ (mm)	D ₂ (mm)	ℓ (mm)	L (mm)	(g)	(pcs.)
10	15.3	21	9	37	45	10
12	17.8	21	10	37	47	10
14	20.3	22	11	37	56	10
17	24.1	23	12.5	37	69	10
19	26.6	25	14	38	89	10

24410M (mm)	D ₁ (mm)	D ₂ (mm)	ℓ (mm)	L (mm)	(g)	(pcs.)
10	15.3	21	9	37	45	10
12	17.8	21	10	37	47	10
13	19	22	10.5	37	53	10
14	20.3	22	11	37	56	10
15	21.5	22	11.5	37	52	10
16	22.8	22	12	37	62	10
17	24.1	23	12.5	37	69	10
18	25.1	24	13	37	74	10
19	26.6	25	14	38	89	10
21	29.1	27	15.5	38	102	10
22	30.1	28	16	40	113	10
24	32.9	30	17	42	140	10

24425 (E)	D ₁ (mm)	D ₂ (mm)	ℓ (mm)	L (mm)	(g)	(pcs.)
E10	13.2	21	8.2	36	68	10
E12	14.6	21	9.3	37	70	10
E14	16.5	21	10.6	37	75	10
E16	19	21.9	11.8	37	80	10
E18	20.3	21.9	13	37	83	10
E20	22.9	22	14.4	37	121	10

24400M / 24400A

6-point Sockets
6-kant Steckschlüssel
Douilles 6-pans

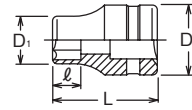

24405M

12-point Sockets
12-kant Steckschlüssel
Douilles 12-pans

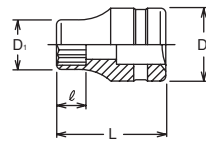

24410M

Surface Drive Sockets
Surface Drive Steckschlüssel
Douilles, Surface Drive

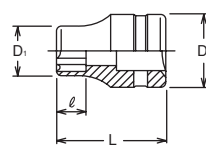

24425

TORX® Sockets
TORX® Steckschlüssel
Douilles TORX®

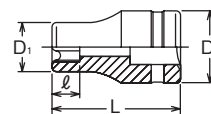

TORX® (E)

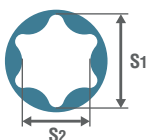

	E	E4	E5	E6	E7	E8	E10	E11	E12	E14	E16	E18	E20	E22	E24	E26	E28
S ₁	(ref. mm)	3.7	4.6	5.6	6.1	7.4	9.3	9.9	11.0	12.8	14.6	16.5	18.3	20.1	22.0	23.7	25.5
S ₂	(ref. mm)	2.7	3.3	4.0	4.3	5.3	6.8	7.1	7.9	9.2	10.5	11.9	13.2	14.8	15.7	17.5	18.3

Z-SERIES
HAND
TITANIUM
ACCESSORIES
SCREWDRIVERS
IMPACT
SLEEVE-DRIVE
PROTECTOR
INDUSTRIAL
AUTOMOTIVE
MOTORCYCLE
CONSTRUCTION
SPARE PART

24300M / 24300A

6-point Sockets, deep
6-kant Steckschlüssel, lang
Douilles longues, 6-pans

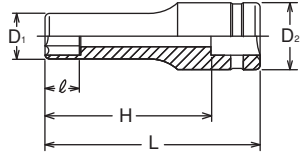

24300M (mm)	D ₁ (mm)	D ₂ (mm)	ℓ (mm)	H (mm)	L (mm)	(g)	(pcs.)
10	15.3	21	11	59	77	91	10
11	16.5	21	12	59	77	95	10
12	17.8	21	13	59	77	99	10
13	19	21.8	14	59	77	107	10
14	20.3	21.8	16	59	77	118	10
15	21.5	21.8	16	59	77	123	10
16	22.8	22	17	59	77	141	10
17	24	23	18	59	77	150	10
18	25	24	19	59	77	164	10
19	26.5	25	20	58	77	177	10
20	27.8	26	21	58	77	178	10
21	29	27	23	58	77	187	10
22	30	28	27	57	77	202	10
24	32.8	30	27	57	77	252	10
27	36.5	33	28	56	77	303	10
30	40	36	34	55	77	342	10
32	42.8	38	34	55	77	405	10

24305M

12-point Deep Sockets
12-kant Steckschlüssel, lang
Douilles longues 12-pans

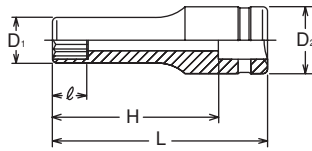

24300A (inch)	D ₁ (mm)	D ₂ (mm)	ℓ (mm)	H (mm)	L (mm)	(g)	(pcs.)
7/16	16.5	21	12	59	77	95	10
1/2	19	21.8	14	59	77	107	10
9/16	20.3	21.8	15	59	77	118	10
5/8	22.8	22	17	59	77	141	10
21/32	24	23	18	59	77	150	10
11/16	25	24	19	59	77	164	10
3/4	26.5	25	20	58	77	177	10
13/16	29	27	23	58	77	187	10
15/16	32.8	30	27	57	77	252	10

24305M (mm)	D ₁ (mm)	D ₂ (mm)	ℓ (mm)	H (mm)	L (mm)	(g)	(pcs.)
10	15.3	21	11	59	77	91	10
12	17.8	21	13	59	77	99	10
14	20.3	21.8	16	59	77	118	10
17	24	23	18	59	77	150	10
19	26.5	25	20	58	77	177	10

24310M

Surface Drive Sockets, deep
Surface Drive Steckschlüssel, lang
Douilles longues, Surface Drive

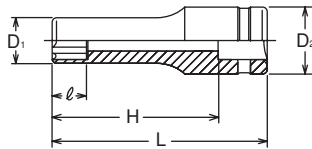

24310M (mm)	D ₁ (mm)	D ₂ (mm)	ℓ (mm)	H (mm)	L (mm)	(g)	(pcs.)
10	15.3	21	11	59	77	91	10
12	17.8	21	13	59	77	99	10
13	19	21.8	14	59	77	107	10
14	20.3	21.8	16	59	77	118	10
15	21.5	21.8	16	59	77	123	10
16	22.8	22	17	59	77	141	10
17	24	23	18	59	77	150	10
18	25	24	19	59	77	160	10
19	26.5	25	20	58	77	177	10
21	29	27	23	58	77	187	10
22	30	28	27	57	77	202	10
24	32.8	30	27	57	77	250	10

24760-75P/-125P/-250P

Extension Bars
Verlängerungen
Rallonges

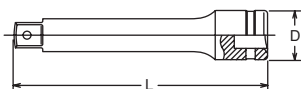

24760	D (mm)	L (mm)	(g)	(pcs.)
75P	24	75	140	10
125P	24	125	200	5
250P	24	250	370	5



AUTOMOTIVE TOOLS
WERKZEUGE FÜR KFZ UND NUTZFAHRZEUGE
OUTILS POUR POIDS LOURDS ET VÉHICULES UTILITAIRES



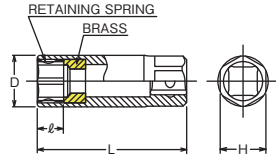

Z-SERIES
 HAND
 TITANIUM
 SCREWDRIVERS ACCESSORIES
 IMPACT
 SLEEVE-DRIVE
 PROTECTOR
 INDUSTRIAL
 AUTOMOTIVE
 MOTORCYCLE
 CONSTRUCTION
 SPARE PART

3300C / 4300C  Spark Plug Sockets with Spring Clips
 Zündkerzen-Schlüssel mit Haltefeder
 Douille avec ressorts de retenue pour bougies



3300C (mm)		D (mm)	ℓ (mm)	L (mm)	H (mm)	(g)	(pcs.)
13		17.5	11	70	17	66	10
14		19	11	70	17	82	10
16		20.5	13	70	17	91	10
18		23.9	12	70	21	140	10
20.8		26.9	13.5	70	22	132	10

4300C (mm)		D (mm)	ℓ (mm)	L (mm)	H (mm)	(g)	(pcs.)
16		21	13	70	21	101	10
18		23.9	12	70	21	132	10
20.8		26.9	13.5	70	22	130	10

3300CB  Spark Plug Socket (BMW)
 Zündkerzen-Schlüssel (BMW)
 Douille pour bougies (BMW)

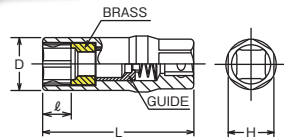

3300CB (mm)		D (mm)	ℓ (mm)	L (mm)	H (mm)	(g)	(pcs.)
16		22.8	13	65	19	118	10

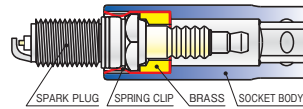



SPARK PLUG SOCKETS with SPRING CLIP
 An internal brass guide holds the clips in place, which ensures perfect alignment of the spark plug into the threaded plug hole of the cylinder head, thus preventing thread damage.
 The brass guide also eliminates stress loading and possible damage to the ceramic insulator of the spark plug.

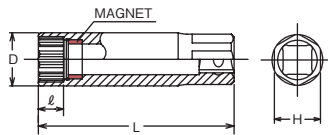

3305P  Spark Plug Socket with Magnet, 12-pt. opening
 Zündkerzensteckschlüssel mit Magnet, 12-kant
 Douille pour bougies, avec aimant, 12-pans





3305P (mm)		D (mm)	ℓ (mm)	L (mm)	H (mm)	(g)	(pcs.)
14		19	8	70	17	87	10
16		20.5	8	70	17	100	10



Spark Plug Socket with Magnet, 12-pt. opening: 3305P-14

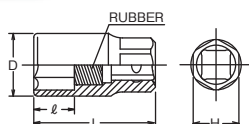

3300S / 4300S  Spark Plug Sockets with Rubber
 Zündkerzen-Schlüssel mit Gummieinsatz
 Douille pour bougies avec caoutchouc



3300S (mm)		D (mm)	ℓ (mm)	L (mm)	H (mm)	(g)	(pcs.)
16		20.9	19	70	17	100	10
18		23.9	21	70	21	145	10
20.8		26.9	27	70	22	140	10

4300S (mm)		D (mm)	ℓ (mm)	L (mm)	H (mm)	(g)	(pcs.)
16		21	19	70	21	100	10
18		23.9	21	70	21	130	10
20.8		26.9	27	70	22	135	10

3300C-180 (mm)		D ₁ (mm)	D ₂ (mm)	ℓ (mm)	L (mm)	(g)	(pcs.)
14	3/8"	19	18	11	180	205	5
16		20.5	18	13	180	220	5
20.8		26.9	18	13.5	180	260	5

3300C-250 (mm)		D ₁ (mm)	D ₂ (mm)	ℓ (mm)	L (mm)	(g)	(pcs.)
14	3/8"	19	18	11	250	271	5
16		20.5	18	13	250	290	5
20.8		26.9	18	13.5	250	340	5



3300C-180/-250

Spark Plug Sockets with Spring Clips
Zündkerzen-Schlüssel mit Haltefedern
Douille avec ressorts de retenue pour bougies

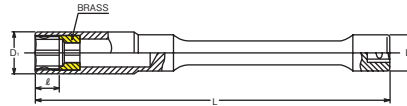

3305P-250

Spark Plug Socket with Magnet, 12pt. opening
Zündkerzensteckschlüssel mit Magnet, 12-kant
Douille pour bougies, avec aimant, 12-pans

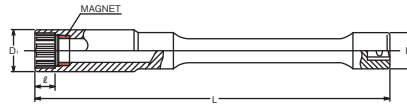

3305P-250 (mm)		D ₁ (mm)	D ₂ (mm)	ℓ (mm)	L (mm)	(g)	(pcs.)
14	3/8"	19	18	8	250	250	5

3340C (mm)		D ₁ (mm)	D ₂ (mm)	ℓ (mm)	L (mm)	(g)	(pcs.)
14	3/8"	19	19	11	88	109	10
16		21	19	13	88	122	10
18		23.9	19	12	88	145	10
20.8		26.8	19	13.5	88	174	10

4340C (mm)		D ₁ (mm)	D ₂ (mm)	ℓ (mm)	L (mm)	(g)	(pcs.)
16	1/2"	21	25	13	100	220	10
20.8		26.8	25	13.5	100	250	10

3340C / 4340C

Universal Spark Plug Sockets with Spring Clips
Gelenk-Zündkerzenschlüssel mit Haltefeder
Douille articulée avec ressorts de retenue pour bougies

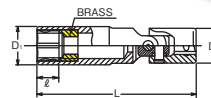

3345P

Universal Spark Plug Socket with Magnet, 12-point opening
Gelenk-Zündkerzensteckschlüssel mit Magnet, 12-kant Ausführung
Clé pour bougies à déclenchement articulée avec aimant, 12 pans

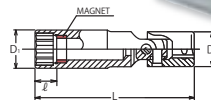

3345P (mm)		D ₁ (mm)	D ₂ (mm)	ℓ (mm)	L (mm)	(g)	(pcs.)
14	3/8"	19	19	8	88	110	10



127C

T-type Universal Spark Plug Socket Wrench
T-Griff mit Gelenk-Zündkerzenschlüssel
Poignée en T avec douille universelle pour bougies

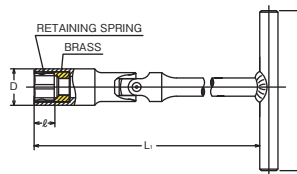
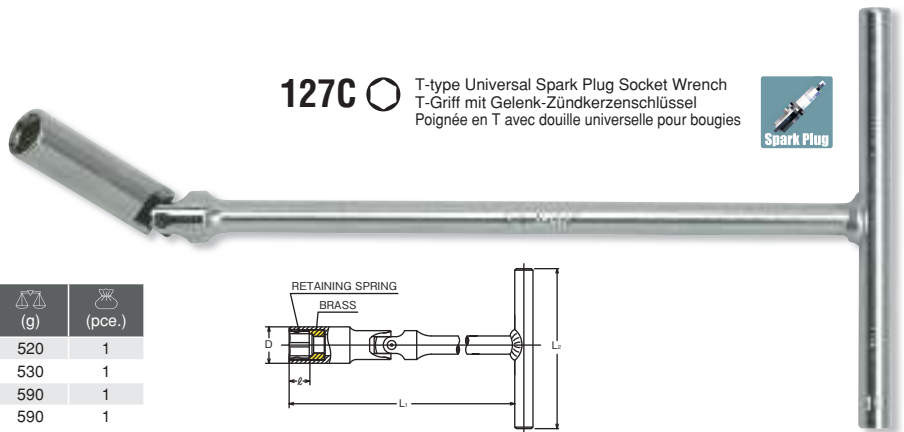

127C-315 (mm)	D (mm)	ℓ (mm)	L ₁ (mm)	L ₂ (mm)	(g)	(pcs.)
14	19	11	315	150	520	1
16	21	13	315	150	530	1
18	23.9	12	315	150	590	1
20.8	26.8	13.5	315	150	590	1

Z-SERIES
 HAND
 TITANIUM
 SCREWDRIVERS ACCESSORIES
 IMPACT
 SLEEVE-DRIVE
 PROTECTOR
 INDUSTRIAL
 AUTOMOTIVE
 MOTORCYCLE
 CONSTRUCTION
 SPARE PART

3751N Torque Ratchet for Spark plugs
 Drehmoment-Knarre für Zündkerzen
 Cliquet pour bougies à déclenchement 25Nm



3751J Torque Ratchet for Spark plugs
 Drehmoment-Knarre für Zündkerzen
 Cliquet pour bougies à déclenchement 25Nm



TORQUE RATCHET

The torque is set at 25Nm. When the torque is loaded higher than 25Nm, the gear slips and no increased torque is transmitted. Cylinder heads and spark plugs are protected by this mechanism.

DREHMOMENT-KNARRE

Die Knarre ist auf ein Drehmoment von 25Nm eingestellt. Ist das Drehmoment von 25Nm erreicht, springt das innere Getriebe über. Dies schützt die Zündkerzengewinde am Zylinderkopf.

CLIQUET À DÉCLENCHEMENT

Le cliquet est fixé à un torque d'une capacité maximale de 25NM. Une fois les 25NM atteints, ce mécanisme évite tout dépassement du cliquet.

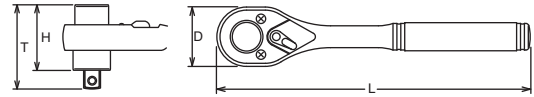

	□	D (mm)	T (mm)	H (mm)	L (mm)	(g)	(pce.)
3751N-25	3/8"	34	57	43	178	320	1
3751J-25	3/8"	34	57	43	178	320	1

3225A Set for Torque Controlled Installation of Spark Plugs
 Set zur Drehmoment kontrollierten Montage von Zündkerzen
 Jeu qui permet la rotation contrôlée lors du montage des bougies à déclenchement



3225A		4 Pieces Set/△=960g	
METAL CASE:W215xH80xT47mm			
Sockets		Accessories	
○	3300C Spark Plug Sockets 16, 20.8		3751J-25
			3763-125

3701-20Nm/-30Nm Torque Adaptors 20Nm / 30Nm
 Drehmoment-Verbindungsstücke 20Nm / 30Nm
 Adaptateurs dynamométriques 20Nm / 30Nm

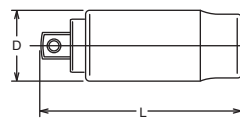

3701	□	D (mm)	L (mm)	(g)	(pce.)
20Nm	3/8"	25.5	75	178	1
30Nm	3/8"	28	75	220	1



2350G-PSG (mm)		D ₁ (mm)	D ₂ (mm)	ℓ (mm)	H (mm)	L (mm)		
12	1/4"	16.5	15.5	12	41	50	41	10

2350G-12PSG

NUT GRIP® Sockets for PSG-Glow Plugs
Steckschlüssel für PSG-Glühkerzen
Douille pour bougies PSG

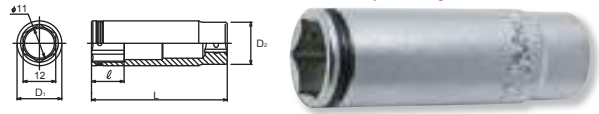

3341G-70 (mm)		D ₁ (mm)	D ₂ (mm)	ℓ (mm)	L (mm)		
10	3/8"	14.5	19	6	70	76	10
11		15.8	19	6	70	80	10
12		17	19	6	70	85	10

3341G-70/-89

Universal PSG Glow Plug Socket with **NUT GRIP®**
Gelenksteckschlüssel für PSG-Glühkerzen mit 2fach Kugelhalterung
Douille articulée pour bougies de préchauffement PSG, avec le système de billes de retenue, double.



3341G-89 (mm)		D ₁ (mm)	D ₂ (mm)	ℓ (mm)	L (mm)		
8	3/8"	12	19	7.5	89	82	10
9		13.3	19	7.5	89	87	10
10		14.5	19	6	89	92	10
12(DP52)		17	19	12	89	101	10

GLOW PLUG SOCKETS, NUT GRIP®

Twin balls at the 6-point opening hold bolt/nut tightly for safe and reliable work.

Die zwei Kugeln in der 6-kant Öffnung unserer NUT GRIP® Glühkerzensteckschlüssel halten die Zündkerze sicher im Steckschlüssel. Dies erlaubt ein Arbeiten auch an schwer zugänglichen Stellen.

Les deux billes se trouvant dans l'ouverture de notre NUT GRIP® (6 pans) pour bougies de préchauffement, maintiennent la bougie de déclenchement dans la douille. Ceci permet l'accès dans les endroits difficilement accessibles.



3342G-150 (mm)		D ₁ (mm)	D ₂ (mm)	ℓ (mm)	L (mm)		
8	3/8"	12	18	7.5	150	137	10

3342G-150

Deep length universal Glow Plug Socket
Extra langer Glühkerzen-Steckschlüssel mit Gelenk
Douille articulée pour bougies de préchauffement, extra longue

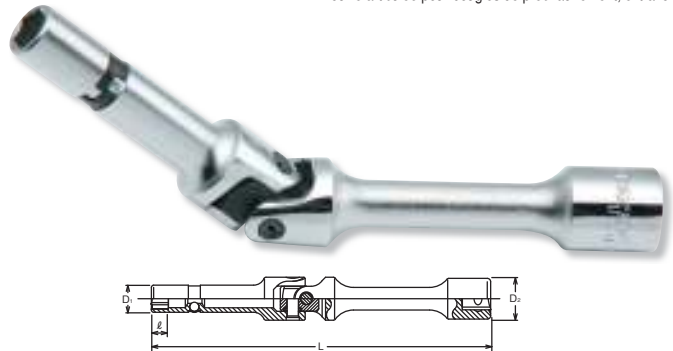

144KM (mm)	L (mm)	D ₁ (mm)	D ₂ (mm)	C (mm)		
8	200	22.7	7.5	95	95	1
12	200	22.7	7.5	102	102	1

144KM

For Glow Plugs
Für Glühkerzen
Pour bougies de préchauffement

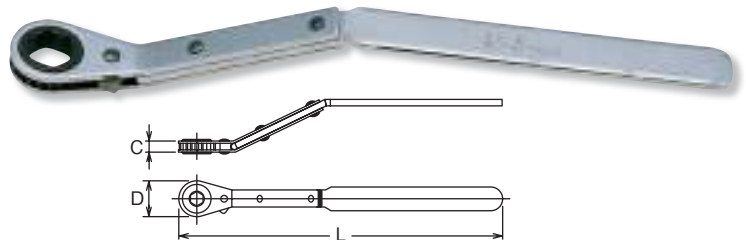

148KM (mm)	L (mm)	D ₁ (mm)	D ₂ (mm)	C (mm)		
8S×12	245	23.6	24.6	9	187	1

148KM

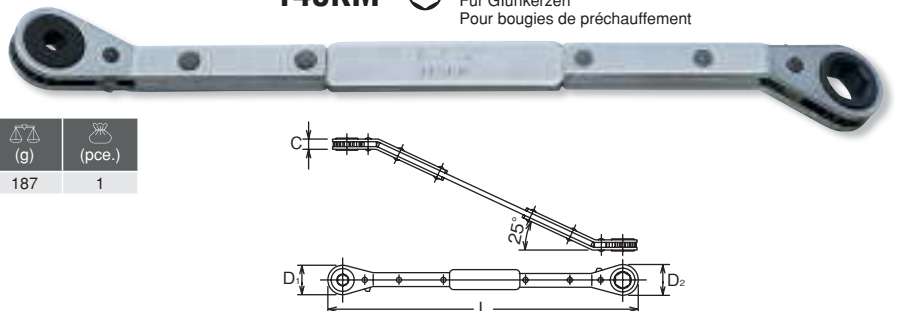

For Glow Plugs
Für Glühkerzen
Pour bougies de préchauffement

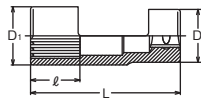

Z-SERIES
 HAND
 TITANIUM
 SCREWDRIVERS ACCESSORIES
 IMPACT
 SLEEVE-DRIVE
 PROTECTOR
 INDUSTRIAL
 AUTOMOTIVE
 MOTORCYCLE
 CONSTRUCTION
 SPARE PART

SP4305M-77  Socket for Diesel engine injectors
 Steckschlüssel für Diesel-Einspritzdüsen
 Douilles spéciales pour injecteurs



SP4305M-77 (mm)		D ₁ (mm)	D ₂ (mm)	ℓ (mm)	L (mm)	 (g)	 (pcs.)
27	1/2"	36.5	33	28	77	212	10

SP4305M.77-27
 For fuel injection pump of BMW diesel cars.

4133  Socket for Diesel engine injectors
 Steckschlüssel für Diesel-Einspritzdüsen
 Douilles spéciales pour injecteurs

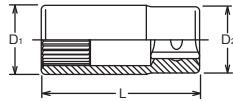



		D ₁ (mm)	D ₂ (mm)	L (mm)	 (g)	 (pcs.)
4133	1/2"	23.9	23	55	86	10

4133
 For fuel injection pump of M.B diesel cars.

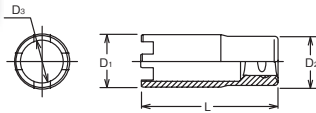
4122-72 Diesel Injection Holder Nut Socket
 Steckschlüssel für Einspritzdüsen
 Douilles pour injecteur diesel





4122-72 (mm)		D ₁ (mm)	D ₂ (mm)	D ₃ (mm)	L (mm)	 (g)	 (pcs.)
22	1/2"	28.5	27	22	72	150	10

4122.72-22
 For M.B Trucks, Holder nut of injection post.

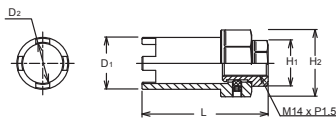

SP4122-69 Diesel Injection Holder Nut Socket
 Steckschlüssel für Einspritzdüsen
 Douilles pour injecteur diesel

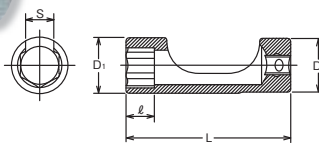

SP4122-69 (mm)	D ₁ (mm)	D ₂ (mm)	H ₁ (mm)	H ₂ (mm)	L (mm)	 (g)	 (pcs.)
22	28.4	22	22	32	69	185	5

3300FN  Flare Nut Sockets
 Geschlitzte Steckschlüssel für Überwurfmutter
 Douilles à tuyauter



3300FN (mm)		D ₁ (mm)	D ₂ (mm)	ℓ (mm)	L (mm)	S (mm)	 (g)	 (pcs.)
8		14.5	17.3	6	53	6.4	38	10
9		16	17.3	7	53	6.8	41	10
10		16.8	17.2	7.5	53	7.2	42	10
11		18	17	8.5	53	8.3	42	10
12		20	18	9	53	8.8	50	10
13		21.1	20	9.5	62	9.4	66	10
14		22	20	10.5	62	10.5	66	10
15	3/8"	23	22	11	70	11.5	82	10
16		24	23	11.5	70	12	90	10
17		25	24	12.5	80	13	110	10
18		27	25	13	80	13.5	120	10
19		28	26	14	80	14.5	130	10
22		32	29.5	16	80	16	180	10
24		34.5	31.5	17	80	17	200	10



RS3300FN/6	6 Pieces Set/Rail 150mm						 (g)
	8, 10, 12, 14, 17, 19						450

RS3300FN/6   Socket Set on Rail
 Steckschlüsselsatz auf Schiene
 Jeu de douilles sur rail

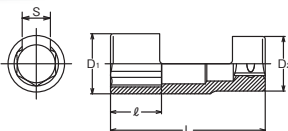

SP4300M-85  Special socket for Lambda Probes
 Spezialsteckschlüssel für Lambda Sonden
SP4300M-110  Douilles spéciales pour sonde Lambda



		D ₁ (mm)	D ₂ (mm)	ℓ (mm)	L (mm)	S (mm)	 (g)	 (pcs.)
SP4300M.85-22	1/2"	33	30	29	85	8	228	10
SP4300M.110-22	1/2"	33	30	34	110	8	279	10

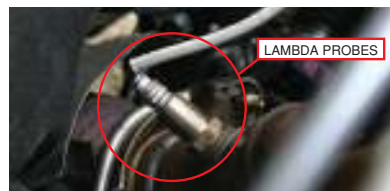

Socket for Lambda Probes
 Open section allows for use with wire/connector.

Z-SERIES
HAND
TITANIUM
ACCESSORIES
SCREWDRIVERS
IMPACT
SLEEVE-DRIVE
PROTECTOR
INDUSTRIAL
AUTOMOTIVE
MOTORCYCLE
CONSTRUCTION
SPARE PART

4300H (mm)		D ₁ (mm)	D ₂ (mm)	ℓ (mm)	H ₁ (mm)	L (mm)	H ₂ (mm)	(g)	(pcs.)
24	1/2"	32.5	27	17	40	57	24	157	10
26		35	27	19	40	57	24	170	10
27		36.1	27	19.5	40	57	24	175	10

4300H series
Removes and installs oil pressure switches

4300H (mm)		D ₁ (mm)	D ₂ (mm)	ℓ (mm)	H (mm)	L (mm)	(g)	(pcs.)
27(8P)	1/2"	34	27	18.5	37	57	152	10

4300H(8P) series
Socket for Switches, Mercedes Benz and MAN

4010M-100 (mm)		D (mm)	H (mm)	L (mm)	(g)	(pcs.)
8(12P)	1/2"	23	63.5	100	132	10
10(12P)		23	63.5	100	135	10

4010M-120 (mm)		D (mm)	H (mm)	L (mm)	(g)	(pcs.)
8(12P)	1/2"	23	83.5	120	151	10
10(12P)		23	83.5	120	155	10



Cylinder head bolt socket for TOYOTA
4010M(12P) is Double Hex bit socket.
XZN(Triple Square) bit socket has different shape.

ST4027.140		D (mm)	H (mm)	L (mm)	(g)	(pcs.)
ST4027.140	1/2"	23	103.5	140	155	10



Head Bolt Bit Socket for VW/AUDI
ST4027-140 can not substitute with 3027, 4027-CV bit series.

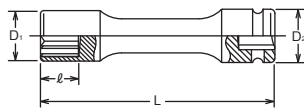

13145M-150 (12P) (mm)		D ₁ (mm)	D ₂ (mm)	ℓ (mm)	L (mm)	(g)	(pce.)	
10	3/8"	15.8	19	10	150	120	1	*1
12		18.3	19	12	150	128	1	*1

*1 C-Ring=1301C, Pin/O-Ring=1301A+B → P250-251

16305M (mm)		D ₁ (mm)	D ₂ (mm)	ℓ (mm)	H (mm)	L (mm)	(g)	(pcs.)	
14	3/4"	26.3	44	14	74	100	500	2	*1
17		30	44	17	74	100	544	2	*1
19		32.5	44	19	74	100	655	2	*1
22		36.3	44	22	74	100	700	2	*1

*1 C-Ring=1600C, Pin/O-Ring=1601A+B → P250-251

4300H Oil Pressure Switch Sockets
Steckschlüssel für Öldruckschalter
Douilles pour interrupteur, pression d'huile

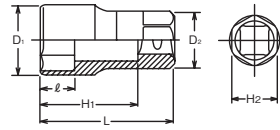

4300H (8P) 8-point Sockets
8-kant Steckschlüssel
Douilles 8-pans

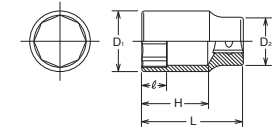

4010M-100/-120 (12P)

Bit Sockets for Double Inhex Screws (12-point)
Steckschlüssel für Innenzwölfkant-Schrauben
Douilles à 6-pans doubles

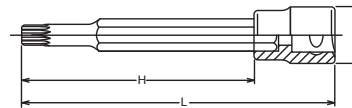

ST4027-140 Head Bolt Bit Socket for VW/AUDI
Bit Steckschlüssel für Zylinderkopfschrauben VW/AUDI
Douilles tournevis spéciales pour boulons de culasse VW/AUDI

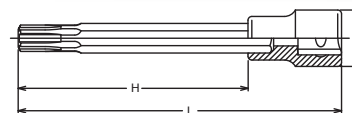

13145M-150/-200 (12P) Extra Long Sockets
Schaftsteckschlüssel
Douilles, série allongée



13145M.200 (12P) (mm)		D ₁ (mm)	D ₂ (mm)	ℓ (mm)	L (mm)	(g)	(pce.)	
10	3/8"	15.8	19	10	200	151	1	*1
12		18.3	19	12	200	159	1	*1

*1 C-Ring=1301C, Pin/O-Ring=1301A+B → P250-251

16305M 12-point Sockets, deep
12-kant Steckschlüssel, lang
Douilles longues, 12-pans

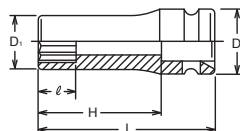

Z-SERIES
 HAND
 TITANIUM
 ACCESSORIES
 SCREWDRIVERS
 IMPACT
 SLEEVE-DRIVE
 PROTECTOR
 INDUSTRIAL
 AUTOMOTIVE
 MOTORCYCLE
 CONSTRUCTION
 SPARE PART

4109M  Double 4-point Sockets
 Doppelvierkant Steckschlüssel
 Douilles 4-pans, doubles

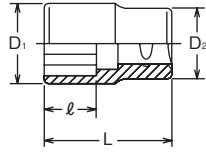

4109M (mm)		D ₁ (mm)	D ₂ (mm)	ℓ (mm)	L (mm)	(g)	(pcs.)
14	1/2"	26.8	26	11	38	110	10
17		30	28	12.5	40	140	10
19		31.5	29	14	40	150	10
21.5		35	32	16	40	170	10
23		37	34	16.5	43	180	10

4109M series
 For Lubrication service

4111M  6-point Sockets
 6-kant Steckschlüssel
 Douilles 6-pans

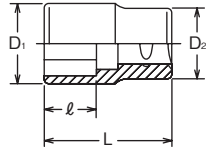

4111M (mm)		D ₁ (mm)	D ₂ (mm)	ℓ (mm)	L (mm)	(g)	(pcs.)
24	1/2"	32	30	17	40	133	10

4111M
 For Lubrication service

4020-60 (MH)  Bit Socket for XZN-Screws with hole
 Steckschlüssel für XZN-Schrauben mit Loch
 Douilles tournevis avec trou pour empreinte XZN

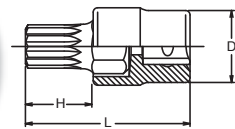



4020-60 (XZN)		D (mm)	H (mm)	L (mm)	(g)	(pcs.)
MH16	1/2"	24	20	60	135	10

4020-60-MH16
 Specially designed for oil drain plug on gearbox of AUDI, VW, PORSCHE.

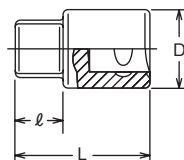

3110M / 3110A  4-point Male Sockets
 Öldienst-Steckschlüssel
 Douilles mâles 4-pans





3110M (mm)		D (mm)	ℓ (mm)	L (mm)	(g)	(pcs.)
6	3/8"	18	10	28	30	10
8		18	10	28	30	10
10		18	10	28	33	10
12		18	10	28	37	10

3110A (inch)		D (mm)	ℓ (mm)	L (mm)	(g)	(pcs.)
5/16	3/8"	18	10	28	30	10
3/8		18	10	28	33	10
1/2		18	10	28	37	10

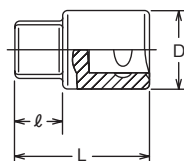
4110M / 4110A  4-point Male Sockets
 Öldienst-Steckschlüssel, Vierkant
 Douilles mâles 4-pans



4110M (mm)		D (mm)	ℓ (mm)	L (mm)	(g)	(pcs.)
8	1/2"	24	10	32	57	10
10		24	10	32	62	10
10.5		24	10	32	64	10
12		24	10	32	64	10
13		24	10	32	66	10
13.5		24	10	32	67	10
19		25	15	37	101	10
20		26	15	37	114	10

4110A (inch)		D (mm)	ℓ (mm)	L (mm)	(g)	(pcs.)
3/8	1/2"	24	10	32	62	10
1/2		24	10	32	64	10

Z-SERIES
HAND
TITANIUM
ACCESSORIES
SCREWDRIVERS
IMPACT
SLEEVE-DRIVE
PROTECTOR
INDUSTRIAL
AUTOMOTIVE
MOTORCYCLE
CONSTRUCTION
SPARE PART

158  For Lubrication Service
Schmierdienst-Werkzeuge
Service lubrification-vidange



158 (mm)	L ₁ (mm)	L ₂ (mm)	d (mm)	(g)	(pcs.)
8Sx10S	63	230	13	319	1



3012M-25 (mm)		D (mm)	L (mm)	(g)	(pcs.)
14	3/8"	19	25	30	10
17		19	25	30	10

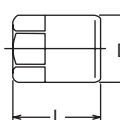

3012M-25  Inhex Sockets
Steckschlüssel für Innensechskant-Schrauben
Douilles tournevis pour vis 6-pans creux



4202 7 Pieces Set/ =426g

METAL CASE:W190xH59xT45mm



Sockets

-  **106** Drain Plug Keys
8Sx10S, 8Hx3/8H, 10Hx11H, 12Hx13H, 14Hx17H, 19H
-  **4102** Drain Plug Key Adaptor

4202 Drain Plug Keys Set
Öldienst-Satz
Jeu d'embouts pour le montage et démontage des bouchons de vidange



106 (mm)	H (mm)	ℓ ₁ (mm)	ℓ ₂ (mm)	L (mm)	(g)	(pcs.)
8Sx10S	17	8	8	32	40	10
8Hx3/8H	17	8	8	32	38	10
10Hx11H	17	8	8	32	42	10
12Hx13H	17	8	8	32	47	10
14Hx17H	17	8	8	32	55	10
19H	17	-	8	24	49	10

106   4-point / 6-point Male bits
Innenvierkant / Innensechskantsteckschlüssel
Embouts mâles 4-pans / 6-pans

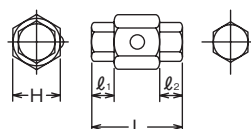

4102 (mm)		D ₁ (mm)	D ₂ (mm)	ℓ (mm)	L (mm)	(g)	(pcs.)
17	1/2"	25	24	16	40	82	10

4102  Adaptor for 106 Drain plug key
Halter für Öldienst-Einsätze 106
Porte embouts pour 106

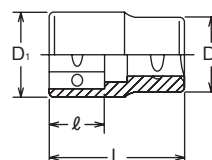

3400M-24 (mm)		D ₁ (mm)	D ₂ (mm)	ℓ (mm)	L (mm)	(g)	(pcs.)
27	3/8"	36.5	21.5	13.5	24	76	10
30		40	25	13.5	24	91	10
32		42.8	28	13.5	24	108	10
36		47.2	32	13.5	24	135	10

3400M-24  Extra short 6-point Sockets for Oil-Filter Service
Extra kurze Steckschlüssel für Ölfilter
Douille extra courte pour filtre à huile

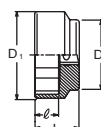

Z-SERIES
 HAND
 TITANIUM
 SCREWDRIVERS ACCESSORIES
 IMPACT
 SLEEVE-DRIVE
 PROTECTOR
 INDUSTRIAL
 AUTOMOTIVE
 MOTORCYCLE
 CONSTRUCTION
 SPARE PART

1206  Push and Pull-Ratchet
 Hub Knarre
 Clé à cliquet de levage



1206		3 Pieces Set/⚖️=320g	
CARDBOARD BOX			
Sockets		Accessory	
 150.14H Sockets 12, 14	154K-14		

154K  Push and Pull-Ratchets
 Hub Knarre
 Clé à cliquet de levage

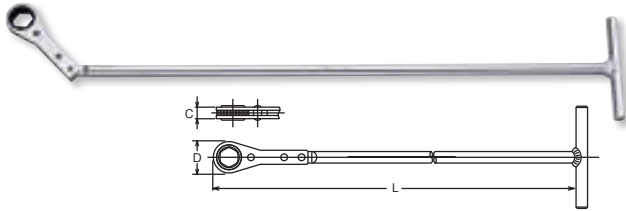

154K (mm)	L (mm)	D (mm)	C (mm)	⚖️ (g)	📦 (pcs.)
14	480	24.6	9	280	1

150-14H  Socket, For 154K
 Einsätze für 154K
 Douilles pour 154K





150-14H (mm)	D (mm)	ℓ (mm)	L (mm)	⚖️ (g)	📦 (pcs.)
10	16	5	17	16	10
12	17.3	5	18	14	10
14	19.2	7	21	17	10

145LH3/8F  Belt Tension Pulley Wrench
 Knarren-Ringschlüssel für Riemen-Spannrolle
 Clé multicrân à cliquet pour galet-tendeur 

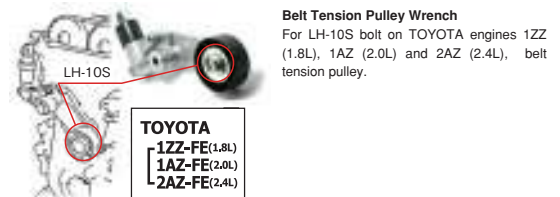

145LH3/8F (LH-S)		L (mm)	D (mm)	C (mm)	⚖️ (g)	📦 (pcs.)
10S	3/8"	100	25	15.5	90	10



 This item has less strength due to the special design.

4282 1/2" Sq.Dr. Generator Service Set
 1/2" Lichtmaschinen-Service Satz
 Jeu 1/2" pour l'entretien des générateurs électriques



4282		4 Pieces Set/⚖️=449g	
PLASTIC BAG			
Sockets			
 4020.100-M10 4020.140-M10			
 4025.100R-T50			
 185			



Generator Service Set
 For removing and installing belt pulley at the generator.

1210E Door Hinge Wrench Set
Montagesatz für Kfz-Türscharniere
Jeux d'outils spéciaux pour charnières de portes



1210E		11 Pieces Set/△=460g
PLASTIC BAG		
Sockets	Accessory	
<ul style="list-style-type: none"> 179B.12H Sockets 10, 12, 13 179B.12H XZN Bits M8, M10, M12 179B.12H TORX® Bits T40, T45, T50 179B.12H Hex Bit 8 	145KD-12	

3247 4 Pieces Set/△=385g
PLASTIC BAG

Sockets

3025.160 Tamper-resistant TORX® Bit Sockets T27H, T30H, T40H, T50H



For Air Bag
For air-bag unit in hard to reach places in or around the steering wheel.

⚠ Tamper Resistant TORX® Bit Sockets have less strength.

3247 ⚠ Bit Socket Set
Schraubendreher-Steckschlüssel Satz
Jeu de douilles de vissage



3300M/4-L120 4 Pieces Set/△=477g
PLASTIC BAG

Sockets

3300M(L120) 6-pt. Extra Deep Sockets 8, 10, 12, 14



Extra Deep Socket
Extra deep socket can be used to fasten or loosen longer bolts such as Bumper bolt and Door hinge etc.

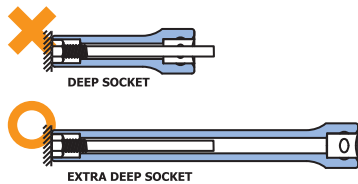

3300M/4-L120 ⚠ Socket Set
Steckschlüssel Satz
Jeu de clés à douille



3350M/2-L120 2 Pieces Set/△=230g
PLASTIC BAG

Sockets

3350M(L120) Nut Grip Extra Deep Sockets 10, 12

Nut Grip Extra Deep Socket

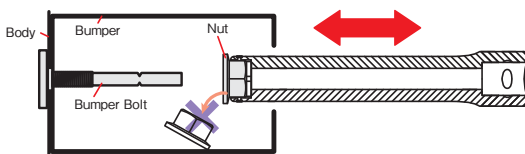

3350M/2-L120 ⚠ Socket Set
Steckschlüssel Satz
Jeu de clés à douille





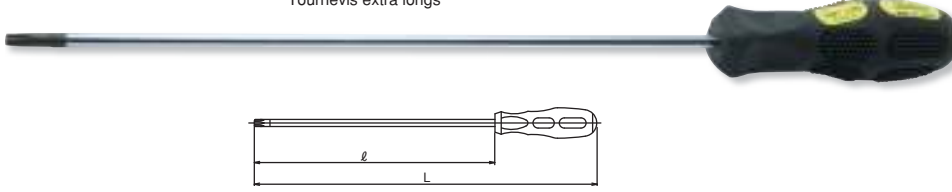

Z-SERIES
 HAND
 TITANIUM
 SCREWDRIVERS ACCESSORIES
 IMPACT
 SLEEVE-DRIVE
 PROTECTOR
 INDUSTRIAL
 AUTOMOTIVE
 MOTORCYCLE
 CONSTRUCTION
 SPARE PART



168T (250)   Extra long shank Screwdrivers
 Extra lange Schraubendreher
 Tournevis extra longs







Long shank Screw Screwdriver

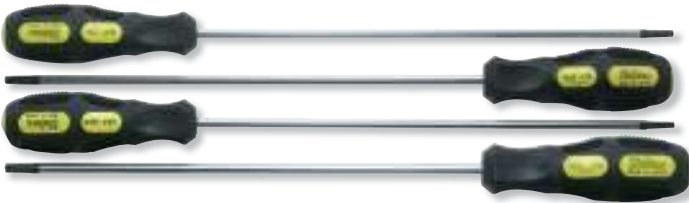

168T(250) (PR)	ℓ (mm)	L (mm)	 (g)	 (pce.)
20PR	250	350	85	1
168T(250) (T)	ℓ (mm)	L (mm)	 (g)	 (pce.)
T20	250	350	85	1
T25	250	350	85	1
T30	250	360	120	1



1212   Long shank Screwdriver 4 pieces set
 Extra lange Schraubendreher 4teiliger Satz
 Tournevis longs. Jeu de 4 pièces

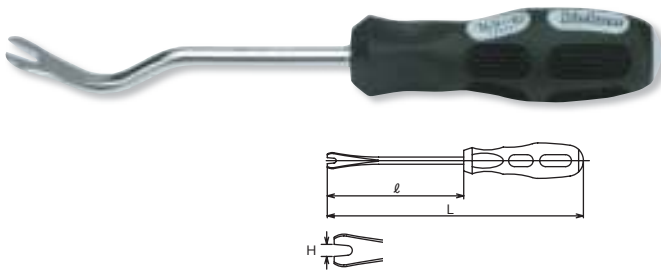

1212	4 Pieces Set/  =380g
PLASTIC BAG	Screwdrivers
 168T(250) 20PR	
 168T(250) T20, T25, T30	

169 Door Trim Pad Tool, 2 pieces set
 Demontagehebel für Türclips, Satz 2-teilig
 Jeu, levier pour le démontage des garnitures de portes



169	ℓ (mm)	L (mm)	H (mm)	 (g)	 (pcs.)
6	115	215	5	80	2
10	120	230	9	110	2



Clip Handle



169/2 Door Trim Pad Tool
 Demontagehebel für Türclips
 Levier pour le démontage des garnitures de portes

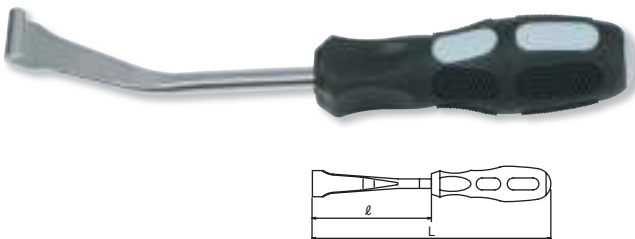

169/2	2 Pieces Set/  =200g
PLASTIC BAG	Clip Handles
	169 6, 10

169WM Window Molding Remover
 Zum Lösen von Fenstergummis
 Pour le démontage des joints de vitres



169WM	ℓ (mm)	L (mm)	 (g)	 (pcs.)
169WM	100	210	90	2



Window Molding Remover

169HR	ℓ (mm)	L (mm)	(g)	(pcs.)
A	100	200	75	2
B	100	200	90	2

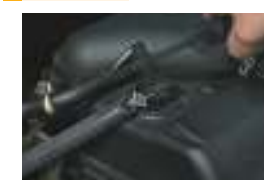

Hose Remover

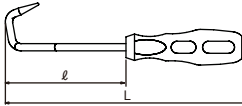
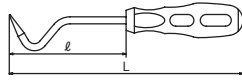

169HR-A Hose Remover
Zum lösen von Schläuchen
Pour le démontage des tuyaux



169HR-B Hose Remover
Zum lösen von Schläuchen
Pour le démontage des tuyaux



169HR/2	2 Pieces Set/△△=180g
PLASTIC BAG	Hose Remover
	169HR A, B

169HR/2 Hose Remover, 2 pieces set
Universalhaken, 2teiliger Satz
Pour le démontage des tuyaux. Jeu de 2 pièces



169BP	T×W (mm)	ℓ (mm)	L (mm)	(g)	(pcs.)
1.8×13	1.8×13	50	150	60	2



For Battery screw



Quick Fastener

169BP For Battery Screws
Für Batterie-Verschlussstopfen
Pour vis de batterie

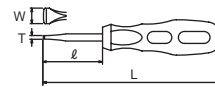

4425 (E)	□	D ₁ (mm)	D ₂ (mm)	ℓ (mm)	L (mm)	(g)	(pcs.)
E10N	1/2"	13.2	21	8.2	36	47	10
E12N		14.6	21	9.3	37	48	10
E14N		16.5	21	10.6	37	50	10
E16N		19	22	11.8	37	60	10
E18N		20.3	22	13	37	60	10
E20N		22.8	22	14.4	37	65	10

4425-N TORX® Sockets
TORX® Steckschlüssel
Douilles TORX®

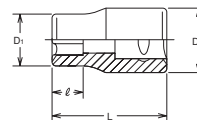

RS4425/6-N	6 Pieces Set/Rail 200mm	(g)
E10N, E12N, E14N, E16N, E18N, E20N		370

RS4425/6-N Socket Set on Rail
Steckschlüsselsatz auf Schiene
Jeu de douilles sur rail



Engine type : QR/MR

Flywheel bolt for NISSAN: E20N

Z-SERIES
 HAND
 TITANIUM
 SCREWDRIVERS ACCESSORIES
 IMPACT
 SLEEVE-DRIVE
 PROTECTOR
 INDUSTRIAL
 AUTOMOTIVE
 MOTORCYCLE
 CONSTRUCTION
 SPARE PART

13145A-150
14145A-150

Extra Long Socket
 Schaftsteckschlüssel
 Douilles, série allongée

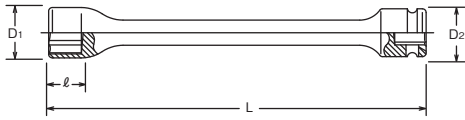

13145A-150 (inch)		D ₁ (mm)	D ₂ (mm)	ℓ (mm)	L (mm)	(g)	(pce.)	
9/16(D20)	3/8"	20	19	13	150	130	1	*1

*1 C-Ring=1301C, Pin/O-Ring=1301A/B → P250-251

14145A-150 (inch)		D ₁ (mm)	D ₂ (mm)	ℓ (mm)	L (mm)	(g)	(pce.)	
9/16(D20)	1/2"	20	25	13	150	200	1	*1

*1 C-Ring=1401C, Pin/O-Ring=1401A/B → P250-251

For Land Rover Prop Shaft

13772-P
14772-P

Universal Double Joint
 Doppelgelenk-Einsatz
 Cardan universel double

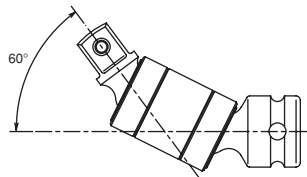
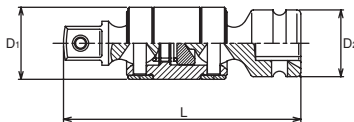

		D ₁ (mm)	D ₂ (mm)	L (mm)	(g)	(pce.)	
13772-P	3/8"	22	19	75	120	5	*1
14772-P	1/2"	27	25	90	230	1	*2

*1 C-Ring=1301C, Pin/O-Ring=1301A/B

*2 C-Ring=1401C, Pin/O-Ring=1401A/B → P250-251



14305M

12-point Deep Sockets
 12-kant Steckschlüssel, lang
 Douilles longues 12-pans

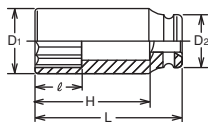

14305M (mm)		D ₁ (mm)	D ₂ (mm)	ℓ (mm)	H (mm)	L (mm)	(g)	(pcs.)	
30		42	30	30	63	85	457	10	*2
32	1/2"	44.5	30	32	63	85	542	10	*2
36		49.5	30	36	61	85	635	2	*2

*1 C-Ring=1402C, Pin/O-Ring=1402A/B → P250-251



4101 / 6101

Sockets for Slotted Heads
 Steckschlüssel für Schlitzschrauben
 Douilles tournevis pour vis à fente

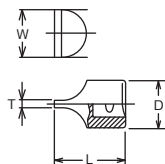

4101		T×W (mm)	D (mm)	L (mm)	(g)	(pcs.)
1		2.7×18.6	22	40	59	10
2	1/2"	3.7×24	24	40	79	10
3		3.7×30	30	40	128	10

6101		T×W (mm)	D (mm)	L (mm)	(g)	(pcs.)
6101	3/4"	6.4×33.5	35	50	205	10

14145PM-110 (mm)		D ₁ (mm)	D ₂ (mm)	ℓ (mm)	Shaft Color	(g)	(pcs.)	
17		23.7	25.2	21	Blue	208	5	*1
19	1/2"	25.7	27.2	23	Red	219	5	*1
21		27.5	29	25	Yellow	226	5	*1
22		29	30.5	26	White	238	5	*1

*1 C-Ring=1401C, Pin/O-Ring=1401A/B → P250-251

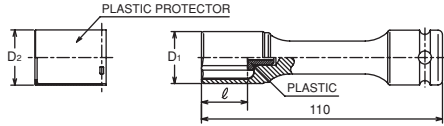

PLASTIC PROTECTOR KUNSTSTOFF HÜLSE PROTECTION EN PLASTIQUE

A detachable plastic protector is fitted to the socket to prevent damage to the wheel when working in tight areas. The socket size and Ko-ken mark printed on the shaft makes it easier to see if the socket is still rotating or stopped.

Zum Schutz empfindlicher Leichtmetallfelgen ist eine drehbare und abnehmbare Kunststoff Hülse an dem Steckschlüssel montiert. Die aufgedruckten Markierungen am Werkzeugschaft zeigen außerdem ob das Werkzeug steht oder rotiert.

La douille est pourvue d'un insert en plastique détachable. Il sert à prévenir tout dommage aux jantes lors de l'utilisation des douilles.

Le marquage sur la tige rend l'identification des douilles très facile.

198-17 : Spare Plastic Protector for 14145PM.110-17 : 10 pcs.

198-19 : Spare Plastic Protector for 14145PM.110-19 : 10 pcs.
280PM-19

198-21 : Spare Plastic Protector for 14145PM.110-21 : 10 pcs.
280PM-21

198-22 : Spare Plastic Protector for 14145PM.110-22 : 10 pcs.

14201M 3 Pieces Set/△=690g

CARDBOARD BOX:W125xH95xT34mm

Sockets

14145PM.110 Impact Wheel Nut Sockets
17, 19, 21

280PM (mm)	D ₁ (mm)	D ₂ (mm)	ℓ (mm)	L (mm)	H (mm)	Shaft Color	(g)	(pcs.)
19	25.7	27.2	13	52	19	Red	150	5
21	27.5	29	13	55	21	Yellow	180	5

Designed for Low Profile Wheel nut socket.

Detachable plastic protector is fitted to the adaptor to prevent damage to painted or surface treatment area on the wheel.

The Plastic insert locate inside of the adaptor prevents damage to wheel nut.

Colour coded band make size identification easy.

Die abnehmbare Kunststoffhülse schützt die Felge vor Kratzern oder Schrammen an der empfindlichen Oberfläche.

Der Kunststoffanschlag im inneren des Werkzeugs schützt zusätzlich die Radmutter.

Die Farbmarkierung macht die Identifikation des Werkzeugs einfach.

La protection plastifiée amovible, protège la jante et évite des dommages sur des surfaces délicates.

Le plastic inséré à l'intérieur de l'outil protège également l'écrou de roue.

L'identification de l'outil est simplifiée par le marquage en couleur.

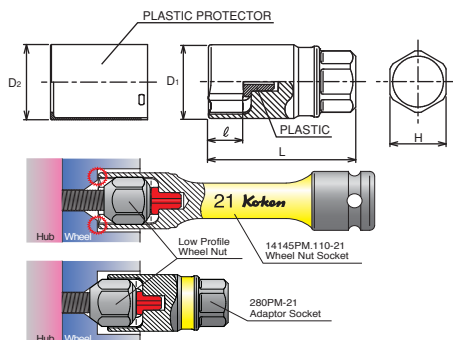

14145PM-110

Wheel Nut Sockets Set
Radmutter Steckschlüssel im Satz
Douilles pour écrous de roue



EXTRA THIN WALL EXTRA DÜNNWANDIG PAROIS EXTRA MINCES

Special design for wheel nut work.

-110mm length gives socket extra reach for nuts recessed deep inside the wheel and ideal for Aluminum wheel nuts where access to nut is very tight.

-Blue(17mm), Red(19mm), Yellow(21mm) and White(22mm) colour coded shafts make size identification easy.

-Plastic insert helps prevent damaged to wheel nut.

Speziell entwickelt für die Montage von Radmuttern

- Die Länge von 110mm erlaubt es mit diesem Steckschlüssel auch extra tiefe Radmuttern zu erreichen.

- Dieser Steckschlüssel ist ideal für Radmuttern von Aluminiumfelgen, da gerade dort der Platz zwischen Schraube und Felge äußerst gering ist.

- Durch die farbige Markierung; blau(17mm), Rot(19mm), Gelb(21mm) und Weiß(22mm) wird die Erkennung des passenden Werkzeugs erleichtert.

- Der Plastikanschlag schützt die Radmutter vor Beschädigungen.

Douilles spécialement conçues pour les écrous de roue :

- La longueur de 110mm permet d'atteindre les écrous enfoncés profondément.

- Idéales pour les écrous des jantes en aluminium où le passage est souvent étroit

- Les corps de couleurs différentes facilitent l'identification : bleu (17mm), rouge (19mm), jaune (21mm) et blanc (22mm)

- Les inserts en plastique évitent de détériorer les jantes.

⚠ Please note that thin walled design is only for wheel nut work and Torque rating is limited.

14201M

Wheel Nut Sockets
Radmutter Steckschlüssel
Douilles pour écrous de roue



280PM

Adaptor Socket for Low Profile Wheel Nut
Adapter Steckschlüssel für kurze Radmuttern
Adaptateur pour des écrous de roue courts



Z-SERIES
 HAND
 TITANIUM
 SCREWDRIVERS ACCESSORIES
 IMPACT
 SLEEVE-DRIVE
 PROTECTOR
 INDUSTRIAL
 AUTOMOTIVE
 MOTORCYCLE
 CONSTRUCTION
 SPARE PART

4300M (L60)



Wheel Nut Sockets (Long)
 Radmuttern-Steckschlüssel, extra lang
 Douilles extra longues pour écrous de roue

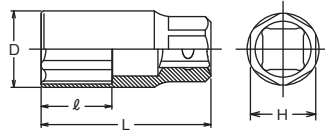

4300M(L60) (mm)		D (mm)	ℓ (mm)	L (mm)	H (mm)	(g)	(pcs.)
17	1/2"	23.6	25	60	21	98	10
19		25.1	25	60	21	100	10
21		27.1	25	60	21	102	10



Wheel Nut Sockets

Please note that thin walled design is only for wheel nut work and Torque rating is limited.

4300M (L110)



Wheel Nut Sockets (Long)
 Radmuttern-Steckschlüssel, extra lang
 Douilles extra longues pour écrous de roue

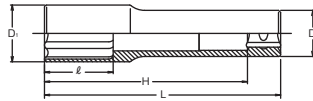

4300M(L110) (mm)		D ₁ (mm)	D ₂ (mm)	ℓ (mm)	H (mm)	L (mm)	(g)	(pcs.)
17	1/2"	23	22	32	93	110	155	5
19		25.8	22	32	93	110	170	5
21		26.8	22	32	93	110	165	5

Please note that thin walled design is only for wheel nut work and Torque rating is limited.

14118M



Wheel Nut Sockets, Double Ended
 Radmuttern-Steckschlüssel, doppelseitig
 Douilles pour écrous de roue à ouvertures doubles

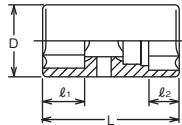

14118M (mm)		D (mm)	ℓ ₁ (mm)	ℓ ₂ (mm)	L (mm)	(g)	(pcs.)
17x19	1/2"	28	15.5	13	48	150	10
19x21		31	17.5	13	57	177	10
19x22		31	17.5	15	57	187	10

14218M



Wheel Nut Sockets, Double Ended with Extension Bar
 Radmuttern-Steckschlüssel, doppelseitig, mit Verlängerung
 Douille pour écrous de roue à ouvertures double plus rallonge



New 14218M 2 Pieces Set/⚖️=360g

CARDBOARD BOX

Sockets		Accessory	
	14118PM 19x21		14760ST-B

Interchangeable Wheel Nut Socket of 19mm and 21mm.

AR14300



Impact Sockets with exchangeable Aluminium Inlets
 Impact Steckschlüssel mit auswechselbarem Aluminium Einsatz
 Douilles Impact avec cartouche en aluminium remplaçable

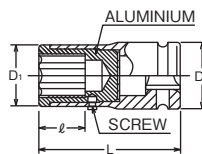

AR14300 (mm)		D ₁ (mm)	D ₂ (mm)	ℓ (mm)	L (mm)	(g)	(pcs.)	
17	1/2"	28	30	21	65	220	10	*1
19		30	30	24	65	223	10	*1
21		33	30	25	65	237	10	*1

*1 C-Ring=1402C, Pin/O-Ring=1402A/B → P250-251

AN14300



Impact Sockets, Aluminium alloyed, for aluminium wheel nuts
 Aluminium-legierte Impact Steckschlüssel für Aluminium Radmuttern
 Douilles Impact en aluminium pour écrous de roue aluminium

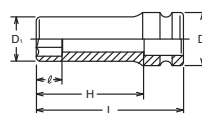

AN14300 (mm)		D ₁ (mm)	D ₂ (mm)	ℓ (mm)	H (mm)	L (mm)	(g)	(pcs.)	
17	1/2"	25.7	30	17	62	80	85	10	*1
19		28.2	30	19	61	80	89	10	*1
21		30.7	30	21	61	80	93	10	*1

*1 C-Ring=1402C, Pin/O-Ring=1402A/B → P250-251

14113J (mm)		D ₁ (mm)	D ₂ (mm)	ℓ (mm)	L (mm)	(g)	(pcs.)	
17	1/2"	25.7	30	14	80	251	10	*1
19		28.2	30	16	80	286	10	*1
21		30.7	30	20	80	309	10	*1

*1 C-Ring=1402C, Pin/O-Ring=1402A/B → P250-251

14113M (mm)		D ₁ (mm)	D ₂ (mm)	ℓ (mm)	L (mm)	(g)	(pcs.)	
17	1/2"	25.7	30	34	80	230	10	*1
19		28.2	30	38	80	262	10	*1
21		30.7	30	42	80	285	10	*1

*1 C-Ring=1402C, Pin/O-Ring=1402A/B → P250-251

14124 (mm)		D ₁ (mm)	D ₂ (mm)	ℓ ₁ (mm)	ℓ ₂ (mm)	L (mm)	(g)	(pcs.)
21×24.5	1/2"	28	29.5	24	25	65	157	10
26×27.5		31.5	35	24.5	24.5	65	197	10

14124/3		3 Pieces Set/△=580g	
CARDBOARD BOX:W125×H91×T43mm			
Sockets		Accessory	
	14124 21×24.5 26×27.5		14760-75B



14113J

Impact Sockets with Plastic Stops for Hub Cap Screws
 Impact Steckschlüssel mit Plastik-Anschlag für Zier-Radmuttern
 Douilles Impact avec arrêt en plastique, pour écrous de roue décoratifs

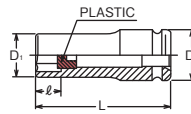

14113M

For Hub Cap Screws
 Für Zier-Radmuttern
 Pour écrous de roue décoratifs

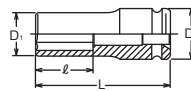

14124

Lock Nut Busters (Double Ended)
 Felgenschloss-Knacker, doppelseitig
 Douilles taraudées à ouvertures doubles pour dévisser les écrous ou goujons de roue antivols.

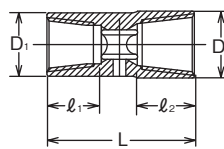

14124/3

Lock Nut Busters (Double Ended) in Set
 Felgenschloss-Knacker, doppelseitig im Satz
 Jeu de douilles taraudées à ouvertures doubles pour dévisser les écrous ou goujons de roue antivols.



14124

Lock Nut Busters
 Felgenschloss-Knacker
 Douilles taraudées pour dévisser les écrous ou goujons de roue antivols.

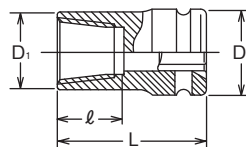

14124 (mm)		D ₁ (mm)	D ₂ (mm)	ℓ (mm)	L (mm)	(g)	(pcs.)	
17	1/2"	20.5	25	15	50	83	10	*1
18		21	25	15	50	83	10	*1
18.5		23	25	15	50	95	10	*1
19		25	30	20.5	50	140	10	*2
21		28	30	20.5	50	153	10	*2
24.5		29.5	30	23	50	138	10	*2
26		31.5	30	23	50	147	10	*2
27.5		35	30	23	50	181	10	*2

*1 C-Ring=1401C, Pin/O-Ring=1401A/B
 *2 C-Ring=1402C, Pin/O-Ring=1402A/B → P250-251

RS14124/7	7 Pieces Set/Rail 250mm	(g)
18, 18.5, 19, 21, 24.5, 26, 27.5		980

RS14124/7

Socket Set on Rail
 Steckschlüsselsatz auf Schiene
 Jeu de douilles sur rail



Z-SERIES
 HAND
 TITANIUM
 ACCESSORIES
 SCREWDRIVERS
 IMPACT
 SLEEVE-DRIVE
 PROTECTOR
 INDUSTRIAL
 AUTOMOTIVE
 MOTORCYCLE
 CONSTRUCTION
 SPARE PART

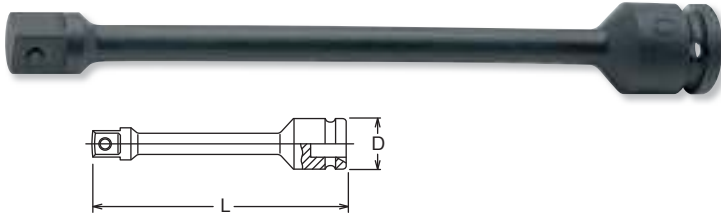

Z-SERIES
 HAND
 TITANIUM
 SCREWDRIVERS ACCESSORIES
 IMPACT
 SLEEVE-DRIVE
 PROTECTOR
 INDUSTRIAL
 AUTOMOTIVE
 MOTORCYCLE
 CONSTRUCTION
 SPARE PART

14112-P  Torsion Extension Bars (for tightening only)
 Torsionsstab-Verlängerungen (nur zum Anziehen)
 Barres de torsion (pour serrage seulement) 



14112-P (Nm)	D (mm)	L (mm)	(g)	(pcs.)	
90Nm	25	208	206	1	*1
95Nm	25	202	200	1	*1
100Nm	25	196	198	1	*1
110Nm	25	213	220	1	*1
120Nm	25	201	219	1	*1
130Nm	25	205	225	1	*1
140Nm	25	205	230	1	*1
150Nm	25	195	250	1	*1
170Nm	25	195	257	1	*1

*1 C-Ring=1401C, Pin/O-Ring=1401A/B → P250-251

14101MP  Torsion Bars (for tightening only)
 Torsionsstäbe (nur zum Anziehen)
 Barres de torsion (pour serrage seulement) 

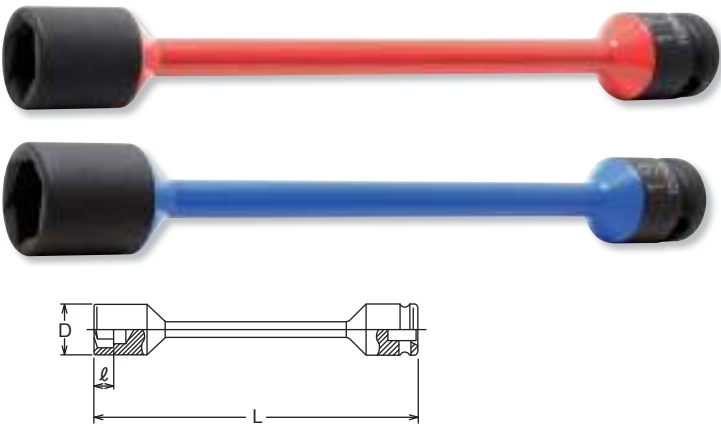

14101MP (mmxNm)	D (mm)	l (mm)	L (mm)	Shaft Color	(pcs.)	
17x 95Nm	25.7	12	214	Yellow	10	*1
17x110Nm	25.7	12	204	Red	10	*1
17x120Nm	25.7	12	200	Green	10	*1
19x 90Nm	28.2	13	259	Yellow	10	*1
19x100Nm	28.2	13	233	White	10	*1
19x120Nm	28.2	13	203	Blue	10	*1
19x140Nm	28.2	13	199	Orange	10	*1
21x100Nm	30.7	14	214	Black	10	*1
21x120Nm	30.7	14	203	Brown	10	*1
22x150Nm	30.7	14	220	Purple	10	*1

*1 C-Ring=1401C, Pin/O-Ring=1401A/B → P250-251

 As the torque could vary with the type and the condition of the impact wrench, we strongly recommend the control with a torque wrench.

Da die Drehmomentwerte von Art und Leistung des verwendeten Schlagschraubers abhängen, empfehlen wir die Kontrolle der Kombination Schlagschrauber/Torsionsstab mittels eines Drehmomentschlüssels.

Etant donné que le couple peut varier selon modèle, la capacité ou l'état de la clé à choc, le contrôle de la combinaison clé à choc/barre par clé dynamométrique est indispensable.

14101MP-M/8  Metal-Wall-Hanger for Workshops
 Werkstatt-Wandhänger (Metall)
 Support métallique d'atelier 



14101MP-M/8 8 Pieces Set/△=2,300g
HANGER
 Torsion Bar
 **14101MP** Impact Torsion Bars
 17x95Nm, 17x110Nm, 17x120Nm,
 19x90Nm, 19x100Nm, 19x120Nm, 19x140Nm, 21x100Nm

- Torsion Bars**
- Designed for tightening wheel nuts with an impact wrench.
 - Prevent the excessive torque road.
 - Color coded shafts make size identification easy.
- Torsionsstäbe**
- Zur Montage von Radmuttern mit dem Schlagschrauber.
 - Schützt die Radmutter vor zu hohen Anzugsmomenten.
 - Die Farbmarkierung erleichtert das Erkennen des passenden Werkzeugs.
- Barres de torsion**
- Pour le montage d'écrous de roue avec visseuse à chocs.
 - Protège l'écroue d'un serrage à couple excessif.
 - La colorisation des barres facilite l'identification des tailles.

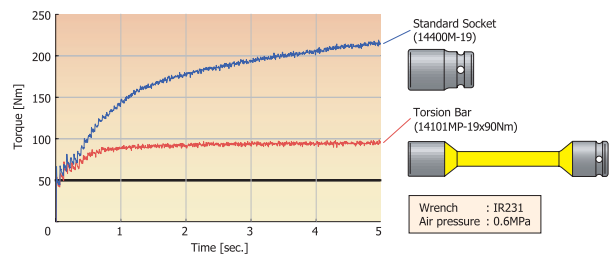

14101M (mmxNm)		D (mm)	ℓ (mm)	L (mm)			
14x 95Nm	1/2"	22	11	208	230	1	*1
15x110Nm		23.2	11	201	230	1	*1
17x 60Nm		25.7	12	216	227	1	*1
17x 75Nm		25.7	12	228	240	1	*1
17x 95Nm		25.7	12	214	256	1	*1
17x110Nm		25.7	12	204	285	1	*1
17x120Nm		25.7	12	200	284	1	*1
19x 60Nm		28.2	13	219	237	1	*1
19x 90Nm		28.2	13	259	275	1	*1
19x110Nm		28.2	13	214	278	1	*1
19x120Nm		28.2	13	203	297	1	*1
19x135Nm		28.2	13	206	339	1	*1
19x170Nm		28.2	13	190	332	1	*1
21x100Nm		30.7	14	214	288	1	*1
21x120Nm	30.7	14	203	288	1	*1	
22x160Nm	32	15	209	385	1	*1	

*1 C-Ring=1401C, Pin/O-Ring=1401A/B → P250-251

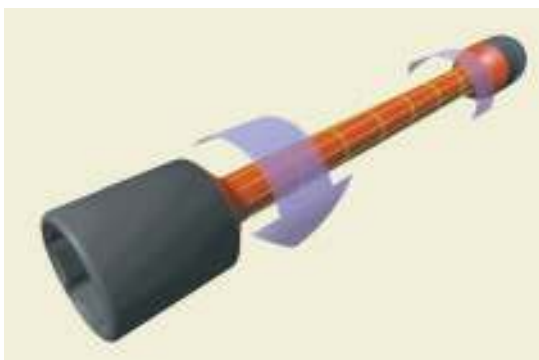

As the torque could vary with the type and the condition of the impact wrench, we strongly recommend the control with a torque wrench.

Da die Drehmomentwerte von Art und Leistung des verwendeten Schlagschraubers abhängen, empfehlen wir die Kontrolle der Kombination Schlagschrauber/Torsionsstab mittels eines Drehmomentschlüssels.

Etant donné que le couple peut varier selon modèle, la capacité ou l'état de la clé à choc, le contrôle de la combinaison clé à choc/barre par clé dynamométrique est indispensable.

14101M Torsion Bars (for tightening only) Torsionsstäbe (nur zum Anziehen) Barres de torsion (pour serrage seulement)

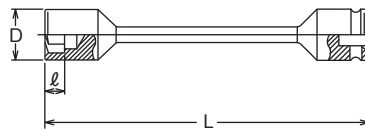

How to use Torsion Bar:

1. Use with a 1/2" Sq. Dr. Pneumatic impact wrench.
2. Set air pressure 0.6MPa, and set impact wrench dial to Medium range.
3. Choose a suitable Torsion bar according to wheel nut size and indicated tightening torque.
4. Attach the torsion bar to impact wrench and apply load.
5. Check the actual tightening torque value with torque wrench.
6. Adjust air pressure or torque value according to the results of check 5.
7. Tight other wheel nut in diagonal order.

Anwendung der Torsionsstäbe:

1. Verwendung mit Druckluft-Schlagschraubern mit 1/2" Anschlussvierkant.
2. Stellen Sie den Druck auf 6 Bar ein, und wählen Sie die mittlere Einstellung am Schlagschrauber.
3. Wählen Sie den passenden Torsionsstab (Kombination aus Schlüsselweite der Radschraube und Drehmoment) aus, und befestigen ihn am Gerät.
4. Ziehen Sie nun die Radmutter an, bis sich der Torsionsstab nicht weiter dreht.
5. Überprüfen Sie das Anzugsmoment mit dem Drehmomentschlüssel.
6. Passen Sie den Luftdruck bzw. die Einstellung am Schrauber dem Resultat der Drehmomentüberprüfung (Punkt 5.) an.
7. Ziehen Sie nun alle Radschrauben diagonal an.

Conseils d'utilisation:

1. A utiliser avec une visseuse à chocs pneumatique en carré entraînant 1/2".
2. Choisissez comme pression d'air 0.6MPa et ensuite la position moyenne de la visseuse.
3. Prenez une barre de torsion correspondant à l'ouverture du 6-pans de la vis ainsi qu'au couple nécessaire.
4. Serrez la vis jusqu'à l'arrêt de la barre de torsion.
5. Contrôlez le couple avec une clé dynamométrique.
6. Ajustez pression et/ou couple selon le résultat du contrôle sous 5.
7. Serrez toutes les vis en diagonale.

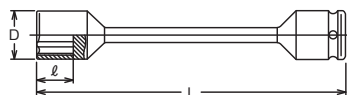

16101M (mmxNm)		D (mm)	ℓ (mm)	L (mm)			
24x180Nm	3/4"	38.8	24	235	850	1	*1
27x450Nm		42.5	27	280	1236	1	*1
32x600Nm		48.8	32	280	1370	1	*1
33x600Nm		50	33	280	1370	1	*1

*1 C-Ring=1600C, Pin/O-Ring=1601A/B → P250-251

As the torque could vary with the type and the condition of the impact wrench, we strongly recommend the control with a torque wrench.

Da die Drehmomentwerte von Art und Leistung des verwendeten Schlagschraubers abhängen, empfehlen wir die Kontrolle der Kombination Schlagschrauber/Torsionsstab mittels eines Drehmomentschlüssels.

Etant donné que le couple peut varier selon modèle, la capacité ou l'état de la clé à choc, le contrôle de la combinaison clé à choc/barre par clé dynamométrique est indispensable.

16101M Torsion Bars (for tightening only) 18101M Torsionsstäbe (nur zum Anziehen) Barres de torsion (pour serrage seulement)



18101M (mmxNm)		D (mm)	ℓ (mm)	L (mm)			
24x350Nm	1"	43.5	24	300	1380	1	*1
27x350Nm		47	27	300	1401	1	*1
27x450Nm		47	27	300	1579	1	*1
30x500Nm		51	30	300	1563	1	*1
32x450Nm		53.5	32	300	1600	1	*1
32x550Nm		53.5	32	300	1602	1	*1
32x600Nm		53.5	32	300	1602	1	*1
32x700Nm		51.5	32	300	1630	1	*1
33x550Nm		55	33	300	1638	1	*1
33x600Nm		55	33	300	1638	1	*1
36x600Nm		58.5	36	300	1718	1	*1

*1 C-Ring=1801C, Pin/O-Ring=1801A/B → P250-251

Z-SERIES
 HAND
 TITANIUM
 SCREWDRIVERS ACCESSORIES
 IMPACT
 SLEEVE-DRIVE
 PROTECTOR
 INDUSTRIAL
 AUTOMOTIVE
 MOTORCYCLE
 CONSTRUCTION
 SPARE PART

6102M-400
8102M-400

Extra long socket for wheel nuts
 Extra lange Steckschlüssel für Radmuttern
 Douilles extra-longues pour écrous de roue

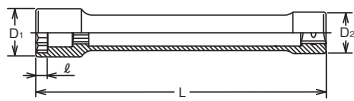

6102M-400 (mm)	□	D ₁ (mm)	D ₂ (mm)	ℓ (mm)	L (mm)	⚖️ (g)	📦 (pce.)
41Wx21W	3/4"	58	40	14	400	1880	1
32		48.5	40	32	400	1480	1
33		49.8	40	32	400	1500	1

8102M-400 (mm)	□	D ₁ (mm)	D ₂ (mm)	ℓ (mm)	L (mm)	⚖️ (g)	📦 (pce.)
41Wx21W	1"	58	49.9	14	400	2610	1
32		48.5	49.9	32	400	2210	1
33		49.8	49.9	32	400	2220	1

⚠️ 6102M/8102M are for hand use only. Do not use with a power tools.



Extra long Socket for wheel nut



Combination type
41Wx21W

16102M-270/-400
18102M-270/-400

Extra long Sockets for wheel Nuts
 Extra lange Steckschlüssel für Radmuttern
 Douilles extra-longues pour écrous de roue

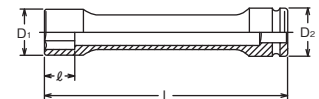

16102M-270 (mm)	□	D ₁ (mm)	D ₂ (mm)	ℓ (mm)	L (mm)	⚖️ (g)	📦 (pce.)	⚡
24	3/4"	38.8	44	24	270	1034	1	*1
27		42.5	44	27	270	1088	1	*1
30		46.3	44	30	270	1144	1	*1
32		48.8	44	32	270	1157	1	*1
33		50	44	32	270	1200	1	*1
36		53.8	44	32	270	1250	1	*1
New 38		56.3	44	32	270	1610	1	*1
New 41		60	44	32	270	1640	1	*1

*1 C-Ring=1600C, Pin/O-Ring=1601A/B → P250-251

16102M-400 (mm)	□	D ₁ (mm)	D ₂ (mm)	ℓ (mm)	L (mm)	⚖️ (g)	📦 (pce.)	⚡
24	3/4"	38.8	44	24	400	1430	1	*1
27		42.5	44	27	400	1460	1	*1
30		46.3	44	30	400	1510	1	*1
32		48.8	44	32	400	1530	1	*1
33		50	44	32	400	1530	1	*1
36		53.8	44	32	400	2180	1	*1

*1 C-Ring=1600C, Pin/O-Ring=1601A/B → P250-251

18102M-270 (mm)	□	D ₁ (mm)	D ₂ (mm)	ℓ (mm)	L (mm)	⚖️ (g)	📦 (pce.)	⚡
23	1"	37.3	54	23	270	1627	1	*1
24		38.5	54	24	270	1628	1	*1
26		41	54	26	270	1667	1	*1
27		42.3	54	27	270	1680	1	*1
29		44.8	54	29	270	1680	1	*1
30		46	54	30	270	1680	1	*1
32		48.5	54	32	270	1680	1	*1
33		49.8	54	32	270	1700	1	*1
34		51	54	32	270	1750	1	*1
36		53.5	54	32	270	1750	1	*1
38		56	54	32	270	1822	1	*1
New 41		60	54	32	270	1800	1	*1

*1 C-Ring=1801C, Pin/O-Ring=1801A/B → P250-251

18102M-400 (mm)	□	D ₁ (mm)	D ₂ (mm)	ℓ (mm)	L (mm)	⚖️ (g)	📦 (pce.)	⚡
23	1"	37.3	54	23	400	1865	1	*1
24		38.5	54	24	400	1869	1	*1
26		41	54	26	400	1925	1	*1
27		42.3	54	27	400	2272	1	*1
29		44.8	54	29	400	2278	1	*1
30		46	54	30	400	2266	1	*1
32		48.5	54	32	400	2322	1	*1
33		49.8	54	32	400	2320	1	*1
34		51	54	32	400	2341	1	*1
36		53.5	54	32	400	2442	1	*1
38		56	54	32	400	2550	1	*1

*1 C-Ring=1801C, Pin/O-Ring=1801A/B → P250-251

PW6 (mmxmm)		D ₁ (mm)	D ₂ (mm)	ℓ (mm)	L (mm)	(g)	(pcs.)	
32x17	3/4"	47	44	12	75	633	2	*1
35x17		50	44	13	75	673	2	*1
38x20		55	44	14	75	708	2	*1
41x19		58	44	14	80	840	2	*1
41x20		58	44	14	80	840	2	*1
41x21		58	44	14	80	831	2	*1

*1 C-Ring=1600C, Pin/O-Ring=1601A/B → P250-251

PW8 (mmxmm)		D ₁ (mm)	D ₂ (mm)	ℓ (mm)	L (mm)	(g)	(pcs.)	
35x17	1"	50	54	13	83	935	2	*1
38x20		55	54	14	83	1038	2	*1
41x19		58	54	14	87	1100	2	*1
41x20		58	54	14	87	1096	2	*1
41x21		58	54	14	87	1089	2	*1

*1 C-Ring=1801C, Pin/O-Ring=1801A/B → P250-251

SIZE	VEHICLE	SIZE	VEHICLE
32 x 17	TOYOTA (~2t)	41 x 19	MAZDA (3~4t)
35 x 17	NISSAN (~3t) MITSUBISHI (~4t) MAZDA (~2t) ISUZU (~3.5t)	41 x 20	TOYOTA (2t~) DAIHATSU (2~3.5t) HINO (2~3.5t)
38 x 20	MITSUBISHI (2~3.5t)	41 x 21	NISSAN (4t~) MITSUBISHI (2t~) ISUZU (4t~) HINO (4t~)

PW8P/4 4 Pieces Set/△=4,250g

CARDBOARD BOX:W240xH95xT70mm

Sockets

PW8P Impact Rear Wheel Nut Sockets
35x17, 38x20, 41x19, 41x21

PW8P (mmxmm)		D ₁ (mm)	D ₂ (mm)	ℓ (mm)	L (mm)	(g)	Shaft Color	(pcs.)	
35x17	1"	50	54	13	83	935	White	5	*1
38x20		55	54	14	83	1038	Red	5	*1
41x19		58	54	14	87	1100	Green	5	*1
41x21		58	54	14	87	1089	Yellow	5	*1

*1 C-Ring=1801C, Pin/O-Ring=1801A/B → P250-251

PW8L (mmxmm)		D ₁ (mm)	D ₂ (mm)	ℓ (mm)	L (mm)	(g)	(pcs.)	
41x21	1"	58	54	15	105	1263	1	*1

*1 C-Ring=1801C, Pin/O-Ring=1801A/B → P250-251

PS6 (mm)		D ₁ (mm)	D ₂ (mm)	ℓ (mm)	L (mm)	(g)	(pcs.)	
17	3/4"	40	44	19	53	433	5	*1
19		40	44	19	53	419	5	*1
20		44	44	21	55	483	5	*1
21		44	44	23	57	491	5	*1

*1 C-Ring=1600C, Pin/O-Ring=1601A/B → P250-251

PS8 (mm)		D ₁ (mm)	D ₂ (mm)	ℓ (mm)	L (mm)	(g)	(pcs.)	
17	1"	40	54	19	60	621	2	*1
19		43	54	19	60	648	2	*1
20		45	54	21	62	687	2	*1
21		45	54	23	64	696	2	*1

*1 C-Ring=1801C, Pin/O-Ring=1801A/B → P250-251

PW6 / PW8

Rear Wheel Nut Sockets
Steckschlüssel für Hinterradmuttern
Douilles spéciales pour écrous de roué arrière

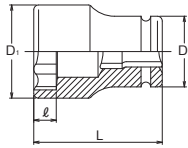

Tightening / Loosening Outer Nut

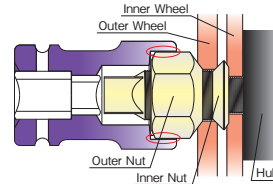

Tightening / Loosening Inner Nut

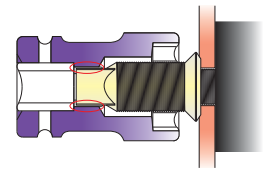

PW8P/4 PW8P

Socket set of Rear Wheel Nut Sockets
Steckschlüssel für Hinterradmuttern, im Satz
Jeu de douilles spéciales pour écrous de roué arrière



PW8L

Rear Wheel Nut Socket (long)
Steckschlüssel für Hinterradmuttern, lang
Douilles spéciales pour écrous de roué arrière longue

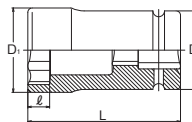

PS6 / PS8

Rear Wheel Nut Sockets
Steckschlüssel für Hinterradmuttern
Douilles spéciales pour écrous de roué arrière

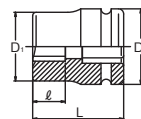

Z-SERIES
 HAND
 TITANIUM
 ACCESSORIES
 SCREWDRIVERS
 IMPACT
 SLEEVE-DRIVE
 PROTECTOR
 INDUSTRIAL
 AUTOMOTIVE
 MOTORCYCLE
 CONSTRUCTION
 SPARE PART

14466A-200B 14488A-B/-200B

Adaptor
 Verbindungsstück
 Réducteur

No Warranty
 Keine Garantie
 Sans Garantie



	□ (sq)	□ (sq)	L (mm)	(g)	(pce.)	⊖
New 14466A-200B	1/2"	3/4"	200	560	1	*1
New 14488A-B	1/2"	1"	58	280	1	*1
New 14488A-200B	1/2"	1"	200	660	1	*1

*1 C-Ring=1402C, Pin/O-Ring=1402A/B → P250-251

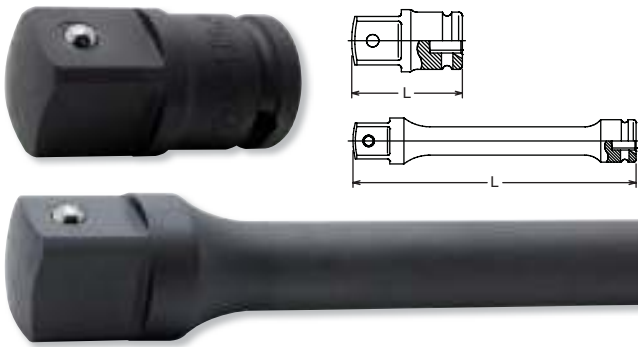

14466A-B / 14488A-B Impact Adaptors (□1/2" SQ. → □3/4", 1" SQ.)

For temporary fastening a wheel nut socket for large vehicle with a light duty 1/2" SQ. DR. Impact wrench.

 Socket is not completely locked with the Ball-type adaptor connection. Please beware of accidental socket release.

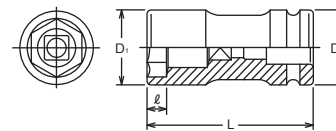

16316M / 16316A 18316M / 18316A

Rear Wheel Nut Sockets
 Steckschlüssel für Hinterradmuttern
 Douilles spéciales pour écrous de roué arrière



16316M (mmxmm)	□	D ₁ (mm)	D ₂ (mm)	ℓ (mm)	L (mm)	(g)	(pce.)	⊖
35x17	3/4"	52	44	10	90	865	1	*1
38x20		56	44	13	100	952	1	*1
41x19		59	44	12	100	1037	1	*1
41x21		59	44	15	100	963	1	*1

*1 C-Ring=1600C, Pin/O-Ring=1601A/B → P250-251

18316M (mmxmm)	□	D ₁ (mm)	D ₂ (mm)	ℓ (mm)	L (mm)	(g)	(pce.)	⊖
35x17	1"	52	54	10	108	1153	1	*1
38x20		56	54	13	108	1133	1	*1
41x19		59	54	12	108	1200	1	*1
41x21		59	54	15	108	1155	1	*1

*1 C-Ring=1801C, Pin/O-Ring=1801A/B → P250-251

16316A (inchxinch)	□	D ₁ (mm)	D ₂ (mm)	ℓ (mm)	L (mm)	(g)	(pce.)	⊖
1.1/2x13/16	3/4"	56	44	13	100	940	1	*1

*1 C-Ring=1600C, Pin/O-Ring=1601A/B → P250-251

18316A (inchxinch)	□	D ₁ (mm)	D ₂ (mm)	ℓ (mm)	L (mm)	(g)	(pce.)	⊖
1.1/2x13/16	1"	59	54	13	108	1120	1	*1

*1 C-Ring=1801C, Pin/O-Ring=1801A/B → P250-251

16317M / 16317A 18317M / 18317A

Rear Wheel Nut Sockets
 Steckschlüssel für Hinterradmuttern
 Douilles spéciales pour écrous de roué arrière

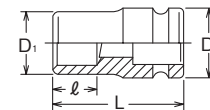

16317M (mm)	□	D ₁ (mm)	D ₂ (mm)	ℓ (mm)	L (mm)	(g)	(pce.)	⊖
17	3/4"	40	44	22.5	67	485	1	*1
19		40	44	22.5	67	462	1	*1
20		44	44	22.5	67	517	1	*1
21		44	44	22.5	67	489	1	*1
22		44	44	22.5	67	482	1	*1

*1 C-Ring=1600C, Pin/O-Ring=1601A/B → P250-251

18317M (mm)	□	D ₁ (mm)	D ₂ (mm)	ℓ (mm)	L (mm)	(g)	(pce.)	⊖
17	1"	40	54	22.5	72	682	1	*1
17.5		40	54	22.5	72	677	1	*1
19		43	54	22.5	72	705	1	*1
20		45	54	22.5	72	723	1	*1
20.5		45	54	22.5	72	723	1	*1
21		45	54	22.5	72	703	1	*1
22		45	54	22.5	72	696	1	*1

*1 C-Ring=1801C, Pin/O-Ring=1801A/B → P250-251

16317A (inch)	□	D ₁ (mm)	D ₂ (mm)	ℓ (mm)	L (mm)	(g)	(pce.)	⊖
13/16	3/4"	44	44	22.5	67	489	1	*1

*1 C-Ring=1600C, Pin/O-Ring=1601A/B → P250-251

18317A (inch)	□	D ₁ (mm)	D ₂ (mm)	ℓ (mm)	L (mm)	(g)	(pce.)	⊖
13/16	1"	45	54	22.5	72	703	1	*1

*1 C-Ring=1801C, Pin/O-Ring=1801A/B → P250-251





MOTORCYCLE TOOLS
MOTORRAD WERKZEUGE
OUTILLAGE MOTO

Z-SERIES
 HAND
 TITANIUM
 ACCESSORIES
 SCREWDRIVERS
 IMPACT
 SLEEVE-DRIVE
 PROTECTOR
 INDUSTRIAL
 AUTOMOTIVE
 MOTORCYCLE
 CONSTRUCTION
 SPARE PART

4400M (DU)  6 point Socket, extra short for Motorcycle central chain-wheel screws
 6 kant Steckschlüssel, extra kurz für Motorrad Kettenrad-Zentralmuttern
 Douille 6-pans, extra-court, pour moto, pour roue d'entraînement écrou-central





4400M (DU)		D ₁ (mm)	D ₂ (mm)	ℓ (mm)	L (mm)	 (g)	 (pcs.)
41	1/2"	53	45	15	28	239	5
46		59	48	15	28	279	5



4405M (DU)  12 point Socket, extra short for motorcycle rear-axle screws
 12 kant Steckschlüssel, extra kurz, für Motorrad-Hinterradmuttern
 Douille 12-pans, extra-court, pour moto, pour écrou roue-arrière





4405M (DU)		D ₁ (mm)	D ₂ (mm)	ℓ (mm)	L (mm)	 (g)	 (pcs.)
36	1/2"	47.3	41	15	28	200	5
55		71	52	16	31	410	5



6405A (MV)  12 point Socket, extra short for motorcycle rear-axle screws
 12 kant Steckschlüssel, extra kurz, für Motorrad-Hinterradmuttern
 Douille 12-pans, extra-court, pour moto, pour écrou roue-arrière





6405A (MV)		D ₁ (mm)	D ₂ (mm)	ℓ (mm)	L (mm)	 (g)	 (pcs.)
2.3/16MV	3/4"	74.6	53	23	52	790	2



4012M-43  Inhex Sockets
 Steckschlüssel für Innensechskant-Schrauben
 Douilles tournevis pour vis 6-pans creux



4012M-43 (mm)		D (mm)	ℓ (mm)	L (mm)	 (g)	 (pcs.)
20	1/2"	26	11.5	43	130	10
21		26	11.5	43	140	10
22		26	11.5	43	145	10
23		28	11.5	43	170	10
24		28	11.5	43	170	10
27		32	11.5	43	226	10



155	D (mm)	d (mm)	L (mm)	(g)	(pcs.)
	22	10	170	100	10

For Motorcycles
 Für Motorräder
 Pour motos



155 Tyre Lever
 Reifen und Montagehebel
 Démonte-pneu

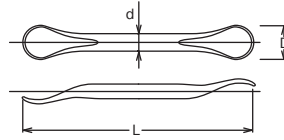

104ME (mm)	D (mm)	ℓ (mm)	L ₁ (mm)	L ₂ (mm)	(g)	(pcs.)
6	9.5	8	200	180	150	1
7	11	9	200	180	152	1
8	12	10	250	200	183	1
9	14	12	250	200	188	1
10	14	13	250	200	230	1
11	16	14	250	200	234	1
12	18	15	250	200	355	1
13	18.5	17	250	250	390	1
14	20	18	250	250	399	1
15	21	19	250	250	404	1
16	22.5	21	250	250	419	1
17	24	22	250	250	568	1
18	25	23	250	250	577	1
19	26.5	25	250	250	594	1

104ME T-Handles, 6-Point
 T-Griffe, 6-kant
 Poignées en T, 6-pans

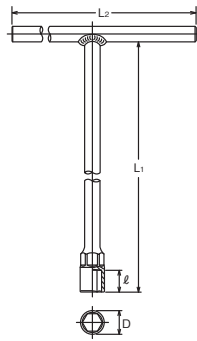

157HE (mm)	L ₁ (mm)	L ₂ (mm)	(g)	(pcs.)
3	250	180	98	1
4	250	180	121	1
5	250	180	158	1
6	250	180	416	1
8	250	180	422	1
10	300	190	440	1
12	320	210	660	1

157PE (PH)	L ₁ (mm)	L ₂ (mm)	(g)	(pcs.)
2	250	180	95	1
3	250	180	170	1

157T (T)	L ₁ (mm)	L ₂ (mm)	(g)	(pcs.)
T25	250	180	95	1
T27	250	180	96	1
T30	250	180	167	1
T40	250	180	168	1
T45	250	180	213	1
T50	250	180	215	1

157HE T-Handles, for Inhex Screws
 T-Griffe für Innensechskant-Schrauben
 Poignées en T, pour vis à 6-pans creux

157PE T-Handles for Phillips Screws
 T-Griffe für Kreuzschlitzschrauben Phillips
 Poignées en T, pour vis à empreinte Phillips



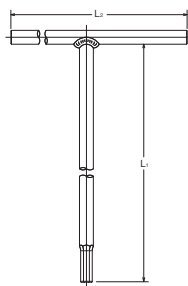





157T T-Handle for TORX® Screws
 T-Griff für TORX®-Schrauben
 Poignées en T pour vis à empreinte TORX®

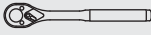

Z-SERIES
 HAND
 TITANIUM
 ACCESSORIES
 SCREWDRIVERS
 IMPACT
 SLEEVE-DRIVE
 PROTECTOR
 INDUSTRIAL
 AUTOMOTIVE
 MOTORCYCLE
 CONSTRUCTION
 SPARE PART

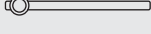







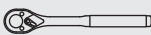

2263A 1/4" Socket set (Inch)
 1/4" Steckschlüsselsatz (Zoll)
 1/4" Jeu de clés à douilles (Pouce)

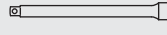
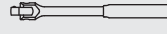

2263A 29 Pieces Set/△=940g	
METAL CASE:W240xH100xT32mm	
Sockets	Accessories
 2400A 6-pt. Sockets 1/8, 5/32, 3/16, 7/32, 1/4, 9/32, 5/16, 11/32, 3/8, 7/16, 1/2	 2753N  2760-100  2769N-150  2770  2785
 2000.28 Bit Sockets 1, 2, 3	
 2010A.25 Bit Sockets 1/8, 5/32, 3/16, 7/32, 1/4, 9/32, 5/16	
 2025.28 Bit Sockets T10, T15, T20, T25, T30	

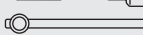





3201AMW 3/8" Socket set (mixed Metric,Inch,Witworth)
 3/8" Steckschlüsselsatz (gemischt Metrisch,Zoll.)
 Jeu de douilles 3/8" (pouce et métrique)

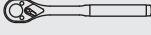

3201AMW 42 Pieces Set/△=4,700g	
METAL CASE:W445xH190xT50mm	
Sockets	Accessories
 3405M 12-pt. Sockets 9, 10, 11, 12, 13, 14, 15, 16, 17, 18, 19, 20, 21, 22	 3753N  3760-75  3760-125  3760-250  3768N-250  3769N-160  3770  3780  3785  3344A
 3405A 12-pt. Sockets 5/16, 3/8, 7/16, 1/2, 9/16, 5/8, 11/16, 3/4, 25/32, 13/16, 7/8	
 3405W 12-pt. Sockets 1/8, 3/16, 1/4, 5/16, 3/8, 7/16, 1/2	

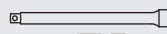
4238AM 1/2" Socket set (mixed Metric,Inch)
 1/2" Steckschlüsselsatz (gemischt Metrisch,Zoll)
 Jeu de douilles 1/2" (pouce et métrique)

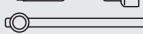

4238AM 38 Pieces Set/△=8,050g	
METAL CASE:W446xH266xT50mm	
Sockets	Accessories
 4405M 12-pt. Sockets 10, 11, 12, 13, 14, 15, 16, 17, 18, 19, 21, 22, 23, 24, 26, 27, 30, 32	 4753N  4760-125  4760-250  4770  4780  4785
 4405A 12-pt. Sockets 3/8, 7/16, 1/2, 9/16, 5/8, 11/16, 3/4, 13/16, 7/8, 15/16, 1.1/16, 1.1/8, 1.1/4	
 4300C Spark Plug Socket 20.8	

4251A 1/2" Socket set (Inch)
 1/2" Steckschlüsselsatz (Zoll)
 Jeu de douilles (pouce) 1/2"



4251A 18 Pieces Set/△=2,660g	
METAL CASE:W330xH68xT48mm	
Sockets	
 4405A 12-pt. Sockets 3/8, 7/16, 1/2, 9/16, 5/8, 19/32, 21/32, 11/16, 3/4, 25/32, 13/16, 7/8, 15/16, 1, 1.1/16, 1.1/8, 1.3/16, 1.1/4	

**TOOLS FOR CONSTRUCTION SITES
WERKZEUGE FÜR DAS BAUWERBE
OUTILLAGE POUR L'INDUSTRIE DU BÂTIMENT**



BD014SE  12-point Nut Setters
 12-kant Steckschlüsselklingen
 Douilles 12-pans à embout

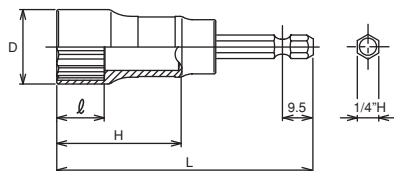

BD014SE (mm)	D (mm)	ℓ (mm)	H (mm)	L (mm)	(g)	(pcs.)
8	12	12	36	77	35	10
10	14	12	36	77	38	10
12	16.5	14	36	77	48	10
13	17.5	14	36	77	51	10
14	19	14	36	77	54	10
17	22.5	14	36	77	76	10
19	24.5	14	36	77	83	10
21	27	14	34	77	104	10
22	28	14	34	77	120	10
24	30.3	14	34	77	140	10

BD014E  12-point Nut Setters, deep
 12-kant Steckschlüsselklingen, lang
 Douilles longues, 12-pans à embout

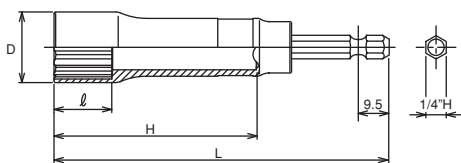

BD014E (mm)	D (mm)	ℓ (mm)	H (mm)	L (mm)	(g)	(pcs.)
8	12	12	63	104	45	10
10	14	12	63	104	52	10
12	16.5	18	63	104	61	10
13	17.5	18	63	104	65	10
14	19	18	63	104	72	10
17	22.5	18	60	104	80	10
19	24.5	18	60	104	95	10
21	27	18	60	104	110	10
22	28	18	60	104	112	10
24	30.3	18	60	104	123	10

BD014E-140  6-point Nut Setters, extra deep
 6-kant Steckschlüsselklingen, extra lang
 Douilles extra-longues, 6-pans à embout

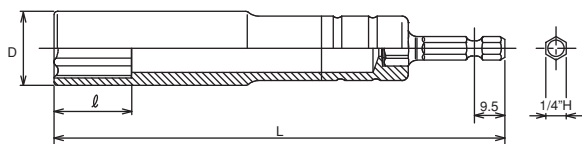

BD014E-140 (mm)	D (mm)	ℓ (mm)	L (mm)	(g)	(pcs.)
13	19	20	140	120	10
17	24	26	140	190	10

BD014XE (mm)	D (mm)	ℓ (mm)	H (mm)	L (mm)	(g)	(pcs.)
8SF	13	12	49	90	40	10
10SF	15	12	49	90	46	10
12SF	17.5	14	48	90	54	10
13SF	18.5	14	48	90	58	10
14SF	19.8	14	47	90	64	10
17SF	23.5	14	46	90	81	10
19SF	25.5	14	46	90	100	10
21SF	28	14	46	90	123	10
24SF	31.5	14	45	90	137	10

BD014E (mm)	D (mm)	ℓ (mm)	H (mm)	L (mm)	(g)	(pcs.)
17SF	23.5	18	60	104	94	10
19SF	25.5	18	60	104	100	10
21SF	28	18	60	104	110	10

BD008E-165 (mm)	D (mm)	ℓ (mm)	H (mm)	L (mm)	(g)	(pcs.)
17(12P)	22.5	17	110	165	105	10
19(12P)	24.5	17	110	165	135	10
21(12P)	27	17	110	165	142	10

BD011SE (mm)	D (mm)	ℓ (mm)	H (mm)	L (mm)	(g)	(pcs.)
10	14	12	35	100	73	10
12	16.5	12	35	100	77	10
13	17.5	12	35	100	79	10
14	19	12	32	100	82	10
17	22.5	14	32	100	87	10
19	24.5	14	30	100	94	10
21	27	14	30	100	103	10
22	28	14	30	100	104	10

BD014XE-SF  Surface Drive Nut Setters, Semi-Deep
Surface Drive Steckschlüsselklingen, mittel lang
Douilles semi-profondes, Surface Drive



BD014E-SF  Surface Drive Nut Setters, deep
Surface Drive Steckschlüsselklingen, lang
Douilles longues, Surface Drive

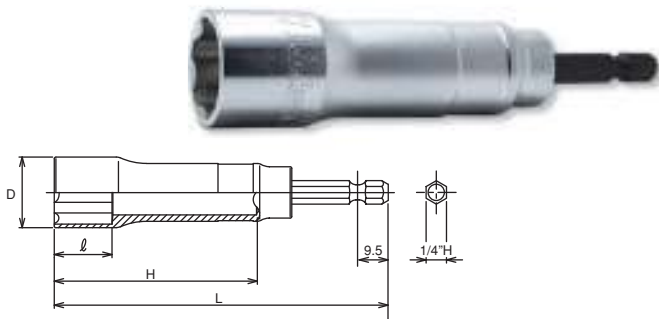

BD008E-165 (12P)  12-point Nut Setter, extra long
12-kant Steckschlüsselklinge, extra lang
Douilles 12-pans à embout, extra longues

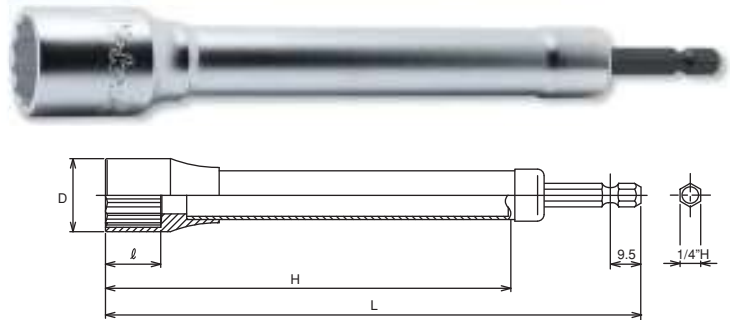

BD011SE  12-point Universal Joint Nut Setters
12-kant Steckschlüsselklingen mit Gelenk
Douilles 12-pans universelles à embout

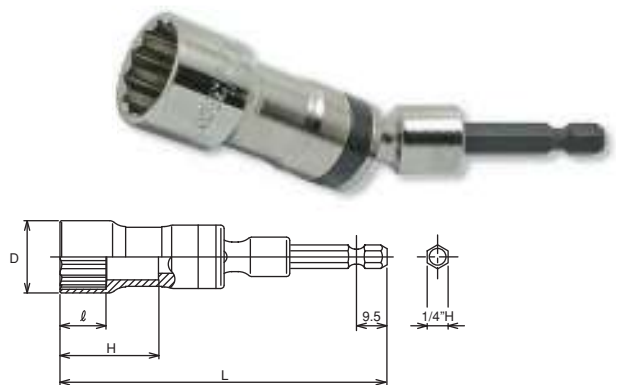



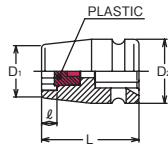

Z-SERIES
HAND
TITANIUM
ACCESSORIES
SCREWDRIVERS
IMPACT
SLEEVE-DRIVE
PROTECTOR
INDUSTRIAL
AUTOMOTIVE
MOTORCYCLE
CONSTRUCTION
SPARE PART

Z-SERIES
 HAND
 TITANIUM
 SCREWDRIVERS ACCESSORIES
 IMPACT
 SLEEVE-DRIVE
 PROTECTOR
 INDUSTRIAL
 AUTOMOTIVE
 MOTORCYCLE
 CONSTRUCTION
 SPARE PART

BD14400MJ  6-point Sockets for Anchor Screws
 6-kant Steckschlüssel
 Douilles 6-pans





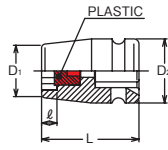

BD14400MJ (mm)		D ₁ (mm)	D ₂ (mm)	ℓ (mm)	L (mm)	 (g)	 (pcs.)	
13	1/2"	20.7	25	5	38	140	10	*1
15		23.2	30	5	38	145	10	*2
16		24.5	30	6.5	38	145	10	*2
17		25.7	30	6.5	38	145	10	*2
19		28.2	30	7.5	38	145	10	*2
21		30.7	30	9	38	185	10	*2
24		34.5	30	10.5	38	190	10	*2

*1 C-Ring=1401C, Pin/O-Ring=1401A/B
 *2 C-Ring=1402C, Pin/O-Ring=1402A/B → P250-251

BD14410MJ  Surface Drive Sockets for Anchor Screws
 Surface Drive Steckschlüssel
 Douilles Surface Drive





BD14410MJ (mm)		D ₁ (mm)	D ₂ (mm)	ℓ (mm)	L (mm)	 (g)	 (pcs.)	
New 13	1/2"	20.7	25	5	38	140	10	*1
New 15		23.2	30	5	38	145	10	*2
New 16		24.5	30	6.5	38	145	10	*2
New 17		25.7	30	6.5	38	145	10	*2
New 19		28.2	30	7.5	38	145	10	*2
New 21		30.7	30	9	38	185	10	*2
New 24		34.5	30	10.5	38	190	10	*2

*1 C-Ring=1401C, Pin/O-Ring=1401A/B
 *2 C-Ring=1402C, Pin/O-Ring=1402A/B → P250-251

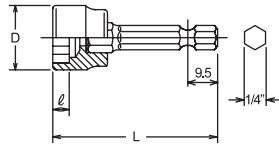
BD016E  6-point Sockets for Anchor Screws
 6-kant Steckschlüssel
 Douilles 6-pans





BD016E (mm)	D (mm)	ℓ (mm)	L (mm)	 (g)	 (pcs.)
13	19.5	4	50	43	10
17	24.5	5	50	56	10
19	27	6	50	68	10

◆ DIN 3126 Form E 6.3

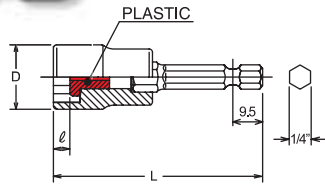
BD016JE  6-point Nut Setters with Plastic Stops
 6-kant Steckschlüsselklingen mit Plastik-Anschlag
 Douilles 6-pans à embout avec arrêt en plastique





BD016JE (mm)	D (mm)	ℓ (mm)	L (mm)	 (g)	 (pcs.)
13	19.5	5	60	66	10
17	24.5	6.5	60	80	10
19	27	7.5	60	90	10

◆ DIN 3126 Form E 6.3

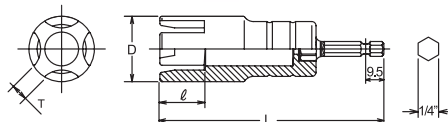
BD017E Wing Bolt Socket for Electric Drill
 6-kant Steckschlüsselklingen für Flügelschrauben
 Douilles 6-pans à embout pour écrous à oreilles



BD017E	D (mm)	T (mm)	ℓ (mm)	L (mm)	 (g)	 (pcs.)
	31	7.3	21	104	158	10

◆ DIN 3126 Form E 6.3



BD018		D (mm)	T (mm)	ℓ (mm)	L (mm)	(g)	(pcs.)	
	3/8"	31	7.3	21	45	113	10	*1

*1 C-Ring=1302C, Pin/O-Ring=1401A/B → P250-251

BD018 Wing Bolt Socket
Steckschlüssel für Flügelschrauben
Douilles pour écrous à oreilles

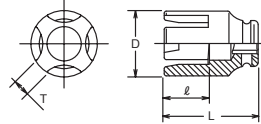

3119		T ₁ ×T ₂ (mm)	D ₁ (mm)	D ₂ (mm)	d (mm)	L (mm)	(g)	(pcs.)
3 x5	3/8"	3 x5	17	17.3	11	30	30	10
5.5x6		5.5x6	21	19.5	14	33	45	10



For Wing Bolt
Für Flügelschrauben
Pour écrous à oreilles



For Drain Plug in Radiator
Für Kühler-Ablasschrauben
Pour le vidange du radiateur

3119 Wing Bolt Socket
Steckschlüssel für Flügelschrauben
Douilles pour écrous à oreilles

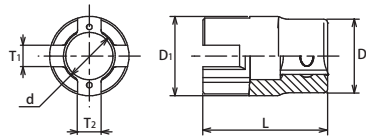

162E (mm)	D (mm)	L (mm)	(g)	(pcs.)
8	23	66	82	10
10	27.9	66	107	10

162E (inch)	D (mm)	L (mm)	(g)	(pcs.)
1/4	23	66	83	10
5/16	23	66	82	10
3/8	27.9	66	107	10
1/2	27.9	66	108	10

◆ DIN 3126 Form E 6.3

162E Stud Setters
Stehbolzeneindreher
Monte-goujons

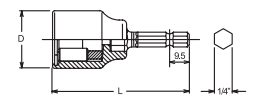
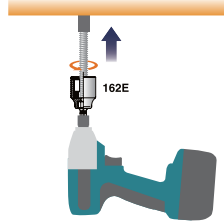

BD004 (mm)		D ₁ (mm)	D ₂ (mm)	L (mm)	(g)	(pcs.)
12.5x10	1/2"	30	25	70	236	5
12.5x13		38	30	75	388	5
12.5x16		38	30	75	369	5
20 x19	3/4"	48	44	90	775	2
20 x22		48	44	90	752	2
20 x25		62	44	95	1184	2
20 x29		62	44	95	1148	2



BD004 Impact Screw and Stud Setters
Impact Stehbolzeneindreher
Monte goujons, Impact

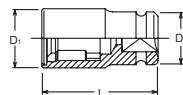

Z-SERIES
 HAND
 TITANIUM
 SCREWDRIVERS ACCESSORIES
 IMPACT
 SLEEVE-DRIVE
 PROTECTOR
 INDUSTRIAL
 AUTOMOTIVE
 MOTORCYCLE
 CONSTRUCTION
 SPARE PART

HA001 Stud Setters
 Stehbolzeneindreher
 Monte-goujons

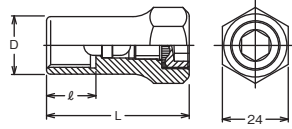

HA001	D (mm)	l (mm)	L (mm)	(g)	(pcs.)
10(1.5)	15.5	13	47	90	10
12(1.25)	17.2	15	49	100	10
16(2.0)	21	18	52	125	10
20(2.5)	24.5	21	56	155	10
22(2.5)	26.5	27	61	175	10
24(3.0)	28	28	62	185	10
W3/8	14.8	13	47	90	10
W1/2	17.6	15	49	105	10

HA003 Drive Part
 Antriebsteil
 Propulseur

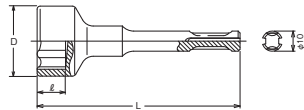

HA003 (mm)	D (mm)	l (mm)	L (mm)	(g)	(pcs.)
24	34.5	14	100	155	10

Socket for HA001



BD022-120P Hammer Drill Adaptor
 Adapter für Schlagbohrmaschinen
 Adaptateur pour aléseuses

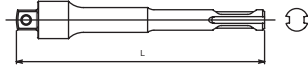

BD022-120P		L (mm)	(g)	(pcs.)
3/8	3/8"	120	100	10
1/2	1/2"	120	160	10

BD023E Adaptors
 Verbindungsstücke
 Adaptateurs

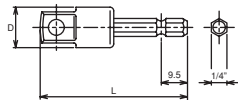

BD023E		D (mm)	L (mm)	(g)	(pcs.)
3/8	3/8"	12.5	55	27	10
1/2	1/2"	16.5	60	48	10

● DIN 3126 Form E 6.3

BD024E Universal Adaptors
 Gelenk Adapter
 Augmentateur universel

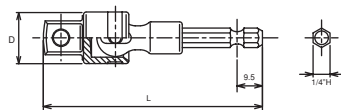

BD024E		D (mm)	L (mm)	(g)	(pcs.)
3/8	3/8"	19.3	78	63	10
1/2	1/2"	19.3	82	73	10

● DIN 3126 Form E 6.3

170S (mm)	D (mm)	T (mm)	L (mm)	(g)	(pce.)
10x12	34	38	250	260	1
12x14	34	38	250	260	1

171S (mm)	D (mm)	T (mm)	L (mm)	(g)	(pce.)
14x17	44.6	50	250	460	1
17x19	44.6	50	250	460	1
17x21	44.6	50	250	460	1
19x21	44.6	50	250	460	1

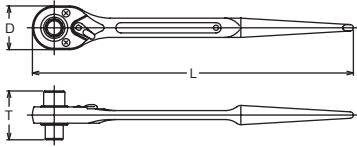

170S ○ Spud Handle Ratchets, reversible
Doppelseitige Gerüstbauknarre, umstellbar
Cliquets, réversibles, pour assemblage et démontage -
échafaudages, manche pointu

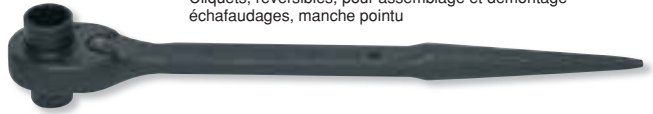

171S ○ Spud Handle Ratchets, reversible
Doppelseitige Gerüstbauknarre, umstellbar
Cliquets, réversibles, pour assemblage et démontage -
échafaudages, manche pointu



171 ○ Spud Handle Ratchets (Long), reversible
Doppelseitige Gerüstbauknarre, lange Ausführung, umstellbar
Cliquets longs, réversibles, pour assemblage et démontage -
échafaudages, manche pointu

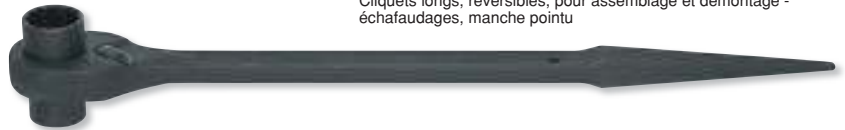

171 (mm)	D (mm)	T (mm)	L (mm)	(g)	(pce.)
14x17	44.6	50	380	630	1
17x19	44.6	50	380	630	1
17x21	44.6	50	380	630	1
19x21	44.6	50	380	630	1

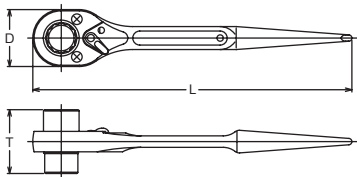

172 ○ Spud Handle Ratchets (Long), reversible
Doppelseitige Gerüstbauknarre, lange Ausführung, umstellbar
Cliquets longs, réversibles, pour assemblage et démontage -
échafaudages, manche pointu



172 (mm)	D (mm)	T (mm)	L (mm)	(g)	(pce.)
21x26	68	58	380	1100	1
22x24	68	58	380	1100	1
23x26	68	58	380	1100	1
24x27	68	58	380	1100	1
26x32	68	63	380	1100	1

171SB-1/2	(mm)	D (mm)	T (mm)	L (mm)	(g)	(pce.)
1/2"	44.6	33	250	480	1	

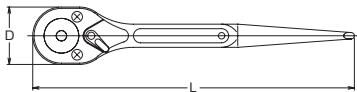

171SB-1/2 Spud Handle Ratchet with Push Button (short)



171B-1/2	(mm)	D (mm)	T (mm)	L (mm)	(g)	(pce.)
1/2"	44.6	33	380	650	1	

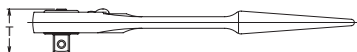

171B-1/2 Spud Handle Ratchet with Push Button(Long)

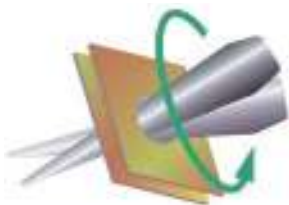

Twin Opening Spud Handle Ratchets
The tapered handle is designed to align bolt holes in flanges, rivet holes or similar assemblies.

Knarren mit doppelseitiger Steckschlüssel-Kombination und konischem Griff für die Ausrichtung von Bohrlöchern z. B. an Flanschen und Gerüsten.

Cliquets à tête double avec manche conique pour aligner les trous des boulons lors des travaux d'échafaudage ou de tout travail de construction.



Ko-ken welcomes customer's enquiries for special tools.
New items can be designed and manufactured according to customers requirements. Please enquire through your distributors.

Wir nehmen auch gerne Ihre Anfrage für Sonderartikel entgegen.
Sonderartikel fertigen wir nach Ihren Anweisungen.
Richten Sie Ihre Anfragen bitte an Ihren örtlichen Händler.

Nous étudierons volontier toute demande d'outils spéciaux.
Nous pouvons concevoir et fabriquer tout outil selon vos spécifications.
Veuillez contacter votre distributeur habituel.

**SPARE PART SETS
ERSATZTEILSÄTZE
PIECES DE RECHANGE**



Z-SERIES
HAND
TITANIUM
ACCESSORIES
SCREWDRIVERS
IMPACT
SLEEVE-DRIVE
PROTECTOR
INDUSTRIAL
AUTOMOTIVE
MOTORCYCLE
CONSTRUCTION
SPARE PART

2749RK



2752RK



2753RK

2753N, 2753PS, 2753P, 2753P-160, 2753J, 2774PS, 2774JS, 2774N, 2774P, 2774J



2753BRK

2753NB, 2753PB, 2753JB



2725RK

2725Z, 2726Z



2749RK-3/8

2749PS-3/8, 2749P-3/8, 2774PS-3/8, 2774JS-3/8



3749RK

3749S



3749BRK

3749SB



3752RK

3752N, 3752J, 3757, 3776N, 3776P, 3776J



3753RK

3753SM, 3753N, 3753P, 3753P-250, 3753J, 3774PS, 3774P-SR, D3753J, 3774N, 3774P, 3774J, 3774NL, 3774PL, 3774JL



3753BRK

3753SMB, 3753NB, 3753PB, 3753JB, 3774NB, 3774PB, 3774JB, 3774JBL

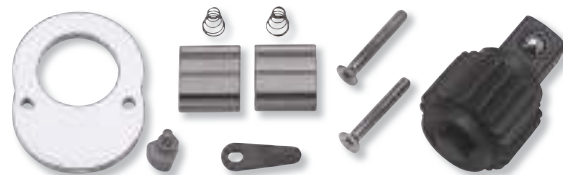

3725RK

3725Z, 3725ZS, 3726Z, 3726ZS



168T-6IP(40)

TORXPLUS® 6IP Screwdriver for 2725RK

168T-8IP(40)

TORXPLUS® 8IP Screwdriver for 3725RK

168T-10IP(40)

TORXPLUS® 10IP Screwdriver for 4725RK



	□	⚖ (g)	⊞ (pce.)	
2749RK	1/4"	30	1	
2752RK		42	1	
2753RK		30	1	
2753BRK		31	1	
2725RK		30	1	
2749RK-3/8		45	1	
3749RK	3/8"	70	1	
3749BRK		84	1	
3752RK		84	1	
3753RK		76	1	
3753BRK		77	1	
3725RK		50	1	
168T-6IP(40)		-	20	1
168T-8IP(40)		-	20	1
168T-10IP(40)		-	22	1

New

3749SRK-1/2 3749S-1/2



3749SBRK-1/2 3749SB-1/2



4749RK 4749N-380, 4749J-380



4750RK 4750N, 4750P, 4750J



4750BRK 4750NB, 4750PB, 4750JB

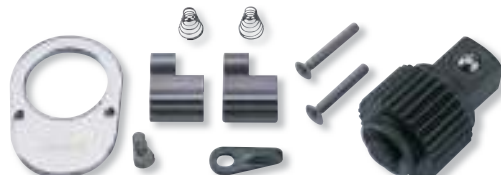

4752RK 4752N, 4752J



4753RK 4753N, 4753P, 4753P-410, 4753J, D4753J
4774N, 4774P, 4774P-450, 4774J



4753BRK 4753NB, 4753PB, 4753JB
4774NB, 4774PB, 4774JB



4725RK 4725Z



6749RK 6749, 6749-1000



6752RK 6752



8749RK 8749



	□	⚖️ (g)	📦 (pce.)
3749SRK-1/2	1/2"	120	1
3749SBRK-1/2		120	1
4749RK		130	1
4750RK		130	1
4750BRK		130	1
4752RK		140	1
4753RK		130	1
4753BRK		130	1
4725RK		130	1
6749RK		3/4"	580
6752RK	600		1
8749RK	800		1

2755RK 2755



3755RK 3755



4755RK 4755



6755RK 6755



	□	(g)	(pce.)
2755RK	1/4"	40	1
3755RK	3/8"	98	1
4755RK	1/2"	137	1
6755RK	3/4"	550	1

2768RK 2768P, 2768J



3768RK 3768P, 3768J

3768ZRK 3768Z



4768RK 4768P, 4768J, 4781N-450

4768ZRK 4768Z



6768RK 6768



8768RK 8768



	□	(g)	(pce.)
2768RK	1/4"	9	1
3768RK	3/8"	21	1
3768ZRK	3/8"	21	1
4768RK	1/2"	60	1
4768ZRK	1/2"	60	1
6768RK	3/4"	200	1
8768RK	1"	475	1

3112RK 3112G



	□	📦 (pce.)
3112RK	3/8"	1
4112RK	1/2"	1
6112RK	3/4"	1

4112RK 4112N, 4112G



6112RK 6112



4100MRK (mm)	□	📦 (pce.)
6	1/2"	1
7		1
8		1
9		1
10		1
10.5		1
11		1
12		1
14		1
16		1

4100ARK (inch)	□	📦 (pce.)
1/4	1/2"	1
5/16		1
3/8		1
7/16		1
1/2		1
9/16		1
5/8		1

6100MRK (mm)	□	📦 (pce.)
18	3/4"	1
20		1
22		1
24		1
27		1
28		1
29		1
30		1

162RK	📦 (pce.)
5/16	1
3/8	1
1/2	1
10	1

4100MRK 4100M/4100A 4100ARK



6100MRK 6100M



162RK

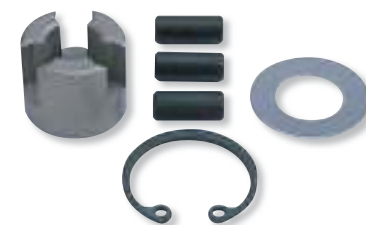

HAND SOCKETS/ Diameter of Bore
 HAND STECKSCHLÜSSEL/ Bohrungsdurchmesser
 DOUILLES A MAIN/ Diamètre d'ouverture

Standard Socket



Deep Socket

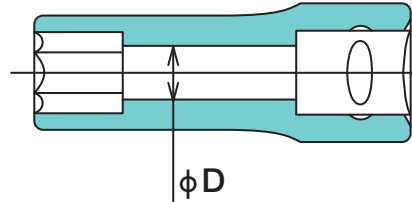
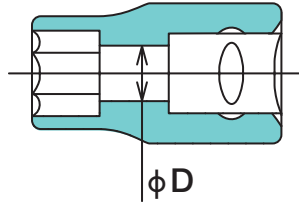

SOCKET		1/4" O		3/8" O		1/2" O		3/4" O		1" O
		Standard	Deep	Standard	Deep	Standard	Deep	Standard	Deep	Standard
		2400M 2400A	2300M 2300A	3400M 3400A	3300M 3300A	4400M 4400A	4300M 4300A	6400M 6400A	6300M 6300A	8400M 8400A
		2405M 2405A	2305M 2305A	3405M 3405A	3305M 3305A	4405M 4405A	4305M 4305A	6405M 6405A	6305M 6305A	8405M 8405A
(mm)	(inch)	ϕD								
3	1/8	2.5	2.5							
4		3	3							
4.5		3.5	3.5							
5	3/16	4	4							
5.5	7/32	4.5	4.5	4.5	4.5					
6	1/4	4.5	5	5	5					
7	9/32	6.2	6	5.5	6					
8	5/16	6.2	7	6	7	6	7			
9	11/32	8.3	8.3	7	8	7	8			
10	3/8	9.4	9	8	9	8	9			
11	7/16	10	10	9	10	9	10			
12		10	11	10	11	10	11			
13	1/2	11.5	12	11	12	11	12			
14	9/16	13	13	13.5	13.5	12	13			
15	19/32			13	14	13	14			
16	5/8			14	15	14	15			
17	21/32			15	16	15	16	15	16	
18	11/16			15	17	15	17	15	17	
19	3/4			16	18	18	18	16	18	
20	25/32			17	19	18	19	17	19	
21	13/16			18	20	18	20	18	20	
22	7/8			19	21	19	21	19	21	
23				20	22	20	22	20	22	
24	15/16			21	23	21	23	21	23	
25				22	24	22	24	22	24	
26	1			23	25	23	25	23	25	
27	1- 1/16				26	23	26	23	26	23
28						24	27	24	27	24
29	1- 1/8					24	28	24	28	24
30	1- 3/16					25	29	25	29	25
31						26	30	26	30	26
32	1- 1/4					27	31	27	31	27
33	1- 5/16					28	32	28	32	28
34						29	33	29	33	29
35	1- 3/8					30	34	30	34	30
36						31	35	31	35	31
37	1- 7/16					31	36	31	36	31
38	1- 1/2					32	37	32	37	32
39								32	38	32
40	1- 9/16							33	39	33
41	1- 5/8							34	40	34
42								34	41	34
43	1-11/16							35	42	35
44	1- 3/4							36	43	36
45								36	44	36
46	1-13/16							37	45	37
47								38	46	38
48	1- 7/8							38	47	38
	1-15/16							39	48	39
50	2							40	49	40
	2- 1/16							40		

IMPACT SOCKETS/ Diameter of Bore
 IMPACT STECKSCHLÜSSEL/ Bohrungsdurchmesser
 DOUILLES IMPACT / Diamètre d'ouverture

Standard Socket

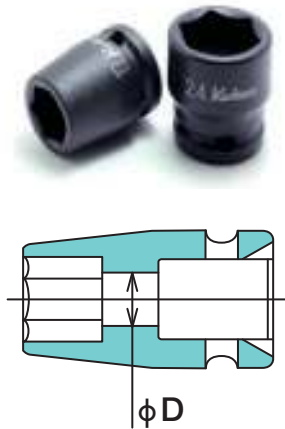

Deep Socket

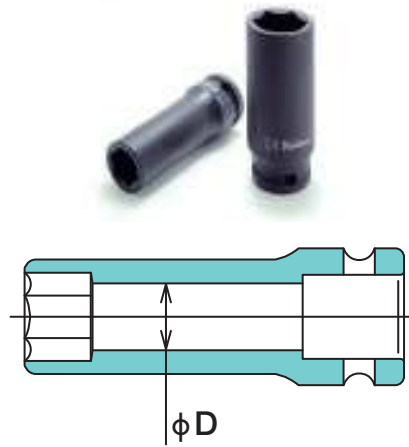

SOCKET		1/4" Ø		3/8" Ø		1/2" Ø		3/4" Ø		1" Ø	
		Standard	Standard	Deep	Standard	Deep	Standard	Deep	Standard	Deep	
Ø		12400M 12400A	13400M 13400A	13300M 13300A	14400M 14400A	14300M 14300A	16400M 16400A	16300M 16300A	18400M 18400A	18300M 18300A	
(mm)	(inch)	φD									
4		3									
4.5	3/16	3									
5		4									
5.5		4									
6	1/4	5	5	5							
7	9/32	5	5	6							
8	5/16	6	6	7	6	7					
9	11/32	7	7	8	7	8					
10	3/8	8	8	9	8	9					
11	7/16	9	9	10	9	10					
12		10	10	11	10	11					
13	1/2	11	11	12	11	12					
14	9/16	12	12	13	12	13					
15			13	14	13	14					
16	5/8		14	15	14	15	14	15			
17	11/16		14	16	14	16	14	16			
18			15	17	15	17	15	17			
19	3/4		16	18	16	18	16	18	16	18	
20			17	19	17	19	17	19	17	19	
21	13/16		18	20	18	20	18	20	18	20	
22	7/8		19	21	19	21	19	21	19	21	
23			20		20	22	20	22	20	22	
24	15/16		20		21	23	21	23	21	23	
25	1				22	24	22	24	22	24	
26					23	25	23	25	23	25	
27	1- 1/16				23	26	23	26	23	26	
28					23	27	24	27	24	27	
29	1- 1/8				23	28	25	28	25	28	
30	1- 3/16				23	29	26	29	26	29	
31					23	30	27	30	27	30	
32	1- 1/4				23	31	28	31	28	31	
33					25	32	29	32	29	32	
34	1- 5/16				25	33	30	33	30	33	
35	1- 3/8				25	34	31	34	31	34	
36					28	35	32	35	32	35	
37	1- 7/16						32	36	32	36	
38	1- 1/2						34	37	34	37	
40	1- 9/16						34	39	34	39	
41	1- 5/8						35	40	35	40	
42	1-11/16						35	41	35	41	
45	1- 3/4						35	44	35	44	
46	1-13/16						40	45	40	45	
47							40	46			
	1- 7/8						40	47			

Screw dimension	Hexagon Head Bolt			Hexagon Socket Head Cap Screws			TORX		TORXPLUS		Triple Square	LHSTIX	Ref.) Standard Tightning Torque (Nm)				
	Standard	Compact	High Strength	Standard	Button Head / Shoulder Head	Hexagon Socket Set Screws	T	E	IP	EP [EPL]	XZN	LH-S [LH-SS]	Grade 4.6	Grade 6.8	Grade 8.8	Grade 10.9	Grade 12.9
M2	4			1.5		0.9	T6/T8		6IP				0.12	0.24	0.32	0.45	0.54
M2.5	5			2		1.3	T8		8IP		M3		0.25	0.49	0.65	0.92	1.1
M3	5.5			2.5	2	1.5	T10	E4	8IP/10IP	4EP	M3		0.43	0.87	1.16	1.63	1.96
M3.5	(6)						T15		10IP/15IP				0.68	1.37	1.82	2.56	3.08
M4	7			3	2.5	2	T20/T25	E5	15IP/20IP	5EP	M4	LH4S	1.01	2.02	2.7	3.79	4.54
M5	8			4	3	2.5	T25/T27	E6	20IP/25IP /27IP	6EP [8EPL]	M5	LH5S	2.04	4.09	5.47	7.67	9.18
M6	10			5	4	3	T30	E8	27IP/30IP	8EP [10EPL]	M6	LH6S	3.47	6.97	9.27	13	15.6
M7	11						T40	E8	40IP	8EP [12EPL]			5.85	11.6	15.5	21.8	26.2
M8	13	(12)		6	5	4	T40/T45	E10	40IP/45IP	10EP [14EPL]	M8	LH8S	8.41	16.9	22.5	31.6	37.9
M10	16 (17)	(14)		8	6	5	T50	E12	45IP/50IP	12EP [16EPL]	M10	LH10S [LH8SS]	16.7	33.4	44.5	62.6	75.2
M12	18 (19)	(17)	21 (22)	10	8	6	T55	E14	55IP	14EP [20EPL]	M12	LH12S [LH10SS]	29.1	58.3	77.6	109	131
M14	21 (22)	(19)		12			T55/T60	E14/E18	55IP/60IP	18EP [24EPL]	M14	LH14S [LH12SS]	46.4	92.7	124	174	209
M16	24	(22)	27	14	10	8	T60/T70	E16/E20	60IP/70IP	20EP [26EPL]	M16	LH16S [LH14SS]	72.3	145	194	271	325
M18	27	(24)		(14)			T70/T80	E24	80IP	24EP [30EPL]	M18		100	199	266	373	447
M20	30 (32)	(27/29)	32	17	12	10	T80/T90	E24	90IP	24EP [32EPL]			141	282	376	529	635
M22	34 (32/35)	(30/32)	36	(17)			T90/T100	E28	100IP	24EP [36EPL]			192	384	511	720	865
M24	36 (38)	(32/35)	41	19		12	T100	E32	100IP	32EP [40EPL]			244	488	650	915	1100
M27	41	(36)	46	(19)				E32		32EP			358	713	951	1340	1610
M30	46	(41)	50	22				E36		36EP			484	971	1290	1820	2180
M33	50	(46)		(24)				E40		40EP			661	1320	1760	2470	2970
M36	55 (54)	(50)		27				E44		44EP			848	1690	2260	3180	3810
M39	60 (58)	(55)		(27)									1100	2190	2920	4110	4930
M42	65 (63)			32									1350	2710	3610	5080	6080
M45	70 (67)			(32)									1700	3400	4540	6370	7630
M48	75 (71)			36									2030	4060	5440	7620	9120
M52	80 (77)			(36)									2640	5290	7040	9880	11800
M56	85			41									3270	6560	8710	12300	14800
M60	90												4080	8180	10900	15300	18300
M64	95			46									4930	9890	13100	18500	22300
M68	(100)												5970	12000	16000	22500	27000

*Reference: Hexagon Head Bolt: ISO 4014-4018, 8676, 8768
 High Strength Hexagon Bolt: JIS B 1196
 Hexagon Socket Head Cap Screws: ISO 7380
 Hexagon Socket Button Head Screws: ISO 7380
 Hexagon Socket Set Screws: ISO 4026-4029
 TORX T/E: TORX Standard TMH series
 TORXPLUS IP/EP: TORXPLUS Standard CMH series
 Triple Square: DIN 2324/2325
 LHSTIX LH-S/SS: LH-S/SS Standard

* Standard Tightening Torque: Calculated based on Torque Coefficient (K): 0.2
 Axial Force (Ff) : 60% of Proof Strength(σ)

TORX is a registered trademark of Acument Intellectual Properties, LLC.
TORX ist ein registriertes Markenzeichen der Firma Acument Intellectual Properties, LLC.
TORX est une marque déposée de Acument Intellectual Properties, LLC.

TORXplus is a registered trademark of Acument Intellectual Properties, LLC.
TORXplus ist ein registriertes Markenzeichen der Firma Acument Intellectual Properties, LLC.
TORXplus est une marque déposée de Acument Intellectual Properties, LLC.

LHSTIX is a registered trademark of OSG CORPORATION System Engineering Department.
LHSTIX ist ein registriertes Markenzeichen der Firma OSG CORPORATION System Engineering Department.
LHSTIX est une marque déposée de OSG CORPORATION System Engineering Department.

TORX® / TORXplus® BITS

		S1 (mm)	S2 (mm)
T6	6IP	1.7	1.2
T7	7IP	2.0	1.4
T8	8IP	2.3	1.7
T9	9IP	2.5	1.8
T10	10IP	2.7	2.0
T15	15IP	3.3	2.3
T20	20IP	3.9	2.8
T25	25IP	4.5	3.2
T27	27IP	5.0	3.6
T30	30IP	5.6	4.0
T40	40IP	6.7	4.8
T45	45IP	7.9	5.6
T50	50IP	8.9	6.2
T55	55IP	11.3	8.0
T60	60IP	13.3	9.5
T70	70IP	15.6	11.1
T80	80IP	17.6	12.7
T90	90IP	20.0	14.2
T100	100IP	22.2	15.8

TORX® / TORXplus® SOCKETS

		S1 (mm)	S2 (mm)
E4	4EP	3.7	2.7
E5	5EP	4.6	3.3
E6	6EP	5.6	4.0
E7	7EP	6.1	4.3
E8	8EP	7.4	5.3
E10	10EP	9.3	6.8
E11	11EP	9.9	7.1
E12	12EP	11.0	7.9
E14	14EP	12.8	9.2
E16	16EP	14.6	10.5
E18	18EP	16.5	11.9
E20	20EP	18.3	13.2
E22	22EP	20.1	14.8
E24	24EP	22.0	15.7
E26	26EP	23.7	17.5
E28	28EP	25.5	18.3
E30	30EP	27.3	20.0
E32	32EP	29.0	21.3

TORXplus® BITS

		S1 (mm)	S2 (mm)
8IPR		2.2	2.0
9IPR		2.4	2.2
10IPR		2.6	2.4
15IPR		3.1	2.8
20IPR		3.6	3.3
25IPR		4.1	3.8
27IPR		4.7	4.3
30IPR		5.2	4.8
40IPR		6.3	5.7
45IPR		7.4	6.7
50IPR		8.4	7.6
55IPR		10.6	9.7

LHSTIX® (LH-S) SOCKETS

		S1 (mm)	S2 (mm)
LH3S		3.8	4.7
LH4S		4.5	6.0
LH5S		5.6	7.5
LH6S		6.8	9.0
LH7S		7.9	10.5
LH8S		9.0	12.0
LH10S		11.3	15.0
LH12S		13.6	18.0
LH14S		15.8	21.0
LH16S		18.1	24.0

XZN BITS

		S1 (mm)	S2 (mm)
M4		3.6	3.1
M5		4.8	4.1
M6		6.1	5.1
M8		7.3	6.1
M10		9.7	8.1
M12		11.5	9.7
M14		13.3	11.2
M16		15.7	13.2
M18		16.9	14.2

Ribe CV BITS

		W (mm)	S1 (mm)	S2 (mm)
M5		1.2	5.0	3.8
M6		1.3	6.0	4.5
M7		1.4	7.0	5.0
M8		1.8	8.0	6.0
M9		2.0	9.0	7.1
M10		2.3	10.0	7.4
M12		2.6	12.0	9.0
M13		3.1	13.0	11.0
M14		3.2	14.0	10.4
M16		3.6	16.0	11.9

TORX® is a registered trademark of Acument Intellectual Properties, LLC.
 TORX® ist ein registriertes Markenzeichen der Firma Acument Intellectual Properties, LLC.
 TORX® est une marque déposée de Acument Intellectual Properties, LLC.

TORXplus® is a registered trademark of Acument Intellectual Properties, LLC.
 TORXplus® ist ein registriertes Markenzeichen der Firma Acument Intellectual Properties, LLC.
 TORXplus® est une marque déposée de Acument Intellectual Properties, LLC.

LHSTIX® is a registered trademark of OSG CORPORATION System Engineering Department.
 LHSTIX® ist ein registriertes Markenzeichen der Firma OSG CORPORATION System Engineering Department.
 LHSTIX® est une marque déposée de OSG CORPORATION System Engineering Department.

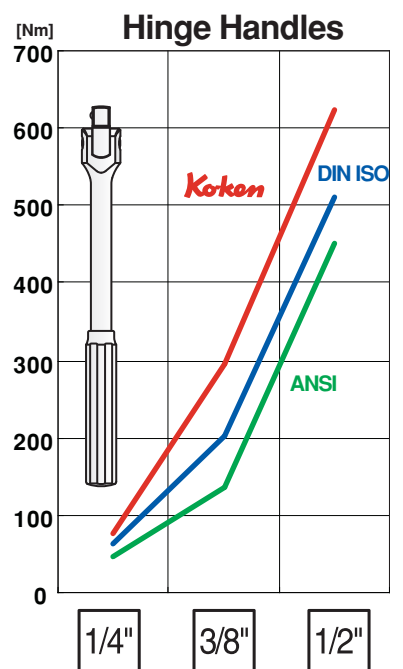
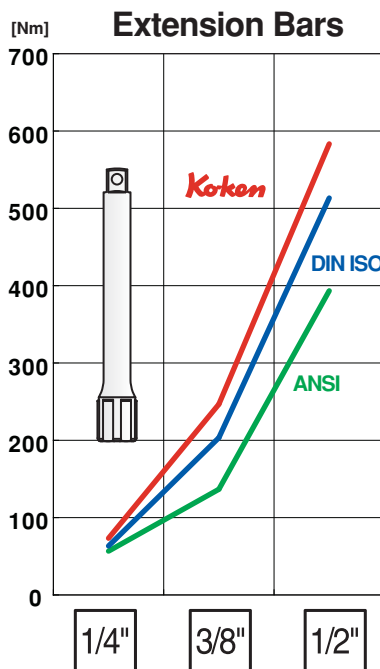
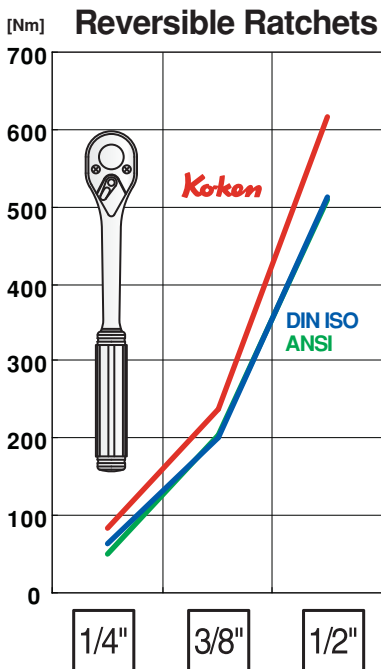
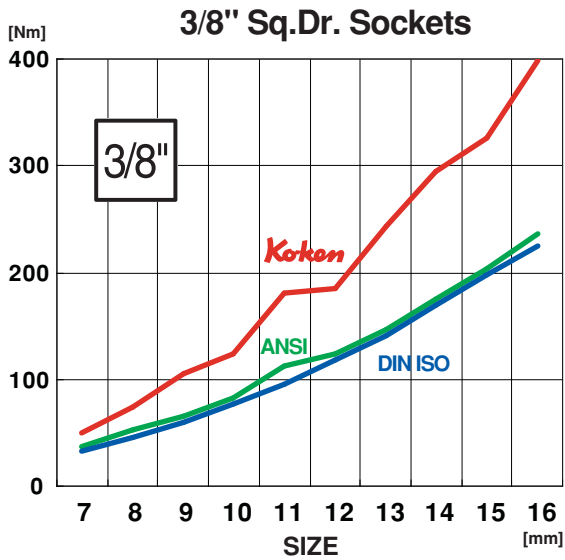
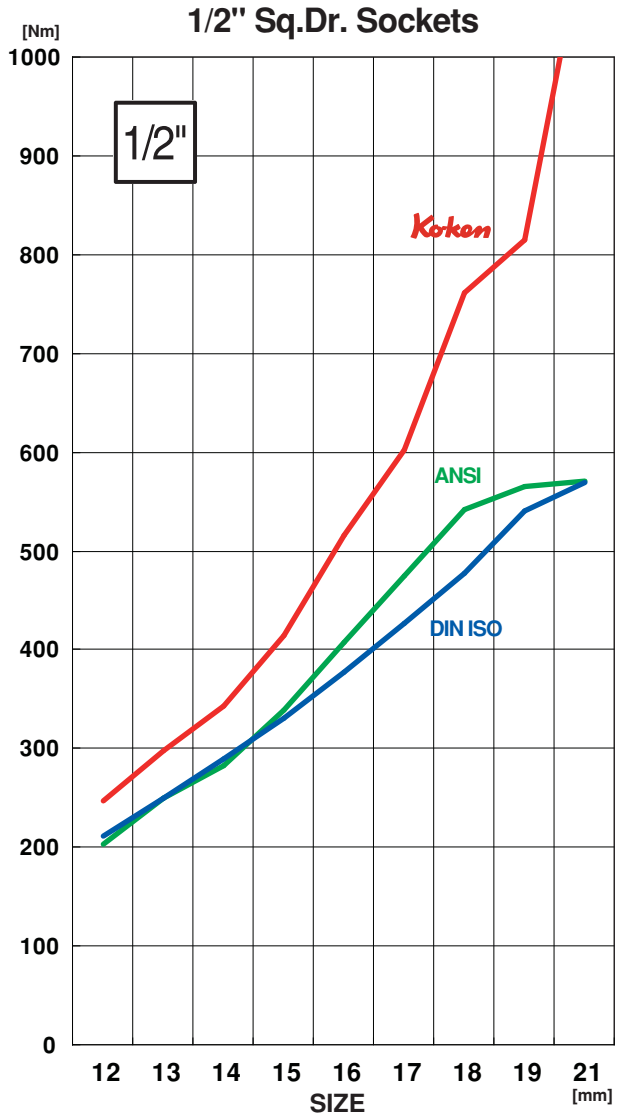
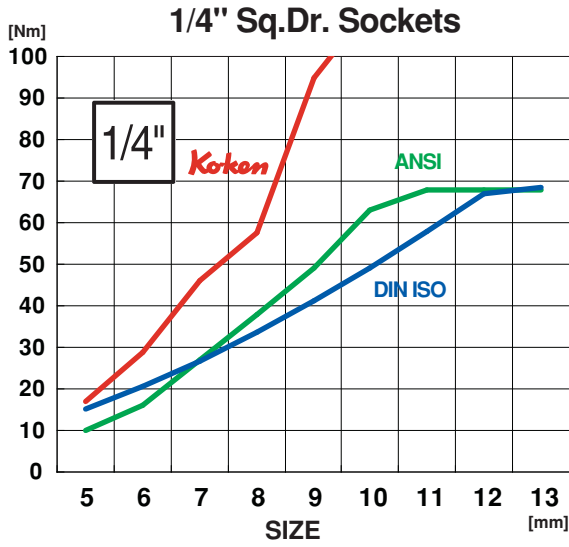

Numerical Index

10099A	242	123PT	159	13425-EPL	181	14365M	201
100H	156	12400A	174	13430M	185	14400A	195
100P	156	12400AG	174	13440A	185	14400M	195
100P (PZ)	156	12400M	174	13440M	185	14400M-FR	255
100S	156	12400MG	174	13440T	185	14400MG	197
100T (T)	156	12410M	174	13460A	181	14400-WN	198
100T (TH)	157	12425	175	13460AG	181	14401A	196
100X (XZN)	157	12460A	175	13460M	181	14401LH	197
101A	143	12460AG	175	13460MG	181	14401M	196
101B	142	12460M	175	13465M	180	14401MS	197
101H	142	12460MG	175	135E	165	14405A	195
101P	142	12465M	175	137	141	14405M	195
101S	142	124M-600 (2B)	146	13760	193	14406A	196
101T (T)	142	12760	177	13760-FR	255	14406M	196
101T (TH)	142	12770	177	13770	194	14410M	197
102KA	138	127C	265	13771	194	14415M	198
102KM	138	128H	143	13772-P	194, 276	14425	198
102KM (BH)	138	128T	143	138	141	14425-EPL	198
102KT	138	13012M	188	139	141	14433A	212
102NA	138	1301A	251	14012M	205	14440A	202
102NM	138	1301B	251	1401A	251	14440M	202
103KA	139	1301C	250	1401B	251	14444AL	211
103KA.BH	139	13025	188	1401C	250	14455A	212
103KM	139	1302A	251	14025	205	14465M	198
103KT	139	1302B	251	1402A	251	14466A	212, 284
10400A	242	1302C	250	1402B	251	14488A-B	284
10400M	242	13103M	133, 188	1402C	250	144KM	267
104A	145	13134	164, 189	141	132	145KM-10H	139
104ME	145, 287	13134M	191	14100A	131, 202	145LH3/8F	272
106	271	13134T (IP)	191	14100M	131, 202	14760	211
107-16	209, 223, 232	13134T (T)	191	14101M	281	14760-FR	255
107-16 (IP)	209, 223, 232	13134X (XZN)	191	14101MP	280	14770	212
107-16 (T)	209, 223, 232	13137E	159	14101MP-M/8	280	14771	212
107-16 (XZN)	209, 223, 232	13139	155, 192	14103M	133, 202	14772-P	212, 276
107-22	224, 233	13140	157, 192	14106	209	148KM	267
107-22 (T)	224, 233	13142-D6.3	155, 192	14112-P	280	149	250
107-32	238	13142-F11.2	164, 189	14113J	279	1500A	251
108A	154	13142-F6.3	159, 192	14113M	279	1500B	251
108H	154	13145A	276	14118M	278	150-10H	139
108P	154	13145M	186	14124	279	150-14H	272
108S	154	13145M (12P)	186, 269	14124/3	279	152	250
108T (T)	154	13145MG	186	14134	164, 206	15300M	215
108T (TH)	154	13146M	187	14134M	208	15310M	215
110	165	13147M	187	14134T (IP)	208	15400M	215
112	165	131P	153	14134T (T)	208	15410M	215
113	160	131S	153	14134X (XZN)	208	154K	272
113 (2B)	161	131T	153	14137E	159	154M	140
113 (E)	160	13241M	194	14139	155, 210	154ML	140
113-SV	256	13242M	194	14140	157, 210	155	287
113UN	160	13300A	182	14142-D6.3	155, 210	15544A-P	216
115	161	13300G	184	14142-F11.2	164, 206	15555AL	216
115G	162	13300M	182	14142-F6.3	159, 210	15566A	216
115G-FR	256	13300XG	182	14145A	276	156M	145
115-SV	256	13301A	183	14145M	203	15770	216
117	165	13301M	183	14145PM	277	157HE	147, 287
119	162	13301X	182	14146M	204	157PE	147, 287
120	165	13305M	183	14147M	204	157S	147
1200A	251	13306M	183	141P	132	157T	147, 287
1200B	251	13310M	184	141S	132	158	271
1201	132	13322A	194	14201M	277	1600C	250
1202	143	13325	184	14207M	214	1601A	251
1203	139	13333AL	193	14208M	214	1601B	251
1206	140, 272	13344A	194	14209M	213	1602A	251
1210E	273	13365M	184	14210M	213	1602B	251
1212	274	13400A	178	14210T	213	160K	134
12137E	159	13400AG	180	14210X	213	16101M	281
12139	155, 176	13400M	178	14218M	278	16102M	282
12140	157, 176	13400M-FR	255	14241M	214	16106	223
12142-F6.3	159, 176	13400MG	180	14242M	214	16106-16	223
121H	158	13400-WN	181	14245M	214	16107	224
121P	158	13401A	179	14300A	199	16107-22	224
121T (IP)	159	13401LH	181	14300G	201	16134	164
121T (T)	158	13401M	179	14300M	199	16201A	226
121T (TH)	158	13401MS	178	14301A	200	16201M	226
12222AL	177	13405A	178	14301M	200	16245M	226
12233A	177	13405M	178	14301X	199	162E	293
12300G	176	13406A	179	14305M	200, 276	162RK	301
12300M	176	13406M	179	14306M	200	16300A	220
12365M	176	13410M	180	14310M	201	16300M	220
123P	159	13425	180	14325	201	16301A	221

16301M	221	18101M	281	2275	52	2755	47
16301X	220	18102M	282	2276	52	2755RK	300
16305M	221, 269	18104M	231	2277	52	2756	47
16310M	222	18106	232	2285ZE	25	2756Z	24
16316A	284	18106-16	232	2286Z	25	2756Z-3/8	24
16316M	284	18107	233	2300A	39	2760	48
16317A	284	18107-22	233	2300M	39	2760Z	24
16317M	284	18300A	230	2300MZ	21	2762	48
16325	222	18300M	230	2300W-BA	39	2763	48
16400A	217	18301A	231	2300X	38	2768J	49
16400M	217	18301M	231	2300XZ	21	2768P	49
16401A	218	18301X	230	2305A	39	2768RK	300
16401M	218	18310M	231	2305M	39	2769H	49
16405A	217	18316A	284	2310M	40	2769N	49, 172
16405M	217	18316M	284	2325	40	2769NWF	49, 172
16410M	218	18317A	284	23300A	260	2770	50
16425	219	18317M	284	23300M	260	2771	50
16425-EPL	219	183H	163, 189, 206, 246	23305M	260	2771Z	24
16644A	225	183T (IP)	163, 190, 207, 246	23310M	260	2772Z	24
16655A	225	183T (T)	163, 190, 207, 246	23325	260	2774J	47
16666AL	225	183X (XZN)	164, 190, 207, 247	23400A	259	2774JS	47
16688A	225	18400A	227	23400M	259	2774JS-3/8	78
166P	170	18400M	227	23405M	259	2774N	47
166PS/6	170	18401A	228	23410M	259	2774P	47
166S	170	18401M	228	23425	259	2774P-1/4HF	152
16760	224	18405A	228	2350G-12PSG	267	2774P-5/16HF	152
16770	225	18405M	228	2350M	41	2774PS	47
16771	225	18405M (D)	229	2350X	38	2774PS-3/8	78
167A	168	18410M	229	23760	260	2780	50
167C (2B)	168	186	165	2400A	36	2785	50
167C/3-2B	168	18760	234	2400M	36	280PM	277
167M	168	18770	234	2400MZ	21	3000 (PH)	66
168C	171	18771	234	2400W-BA	36	3000 (PZ)	66
168CS	171	18866A	235	2405A	36	3005	66
168H-B	169	18877A	235	2405M	36	3010A	67
168P	171	18888AL	234	2410M	37	3010M	67
168P (PZ)	169	1901A	251	2415A	37	3010MZ	28
168PS/6	171	1901B	251	2415M	37	3011M	69
168R	169	1902A	251	2425	37	3012A	68
168S	171	1902B	251	24300A	262	3012M	68, 271
168T (250)	274	19300M	241	24300M	262	3015M	69
168T (IP)	298	19400A	240	24305M	262	3020	70
168T (TH)	169	19400M	240	2430M	42	3025 (IP)	73
168T/7 (TH)	169	19760	241	2430T	42	3025 (IPR)	74
169	274	19770	241	24310M	262	3025 (T)	71
169/2	274	19977A	241	24400A	261	3025 (TH)	72
169BP	275	2000 (PH)	42	24400M	261	3025-100R (T)	71
169HR	275	2000 (PZ)	42	24405M	261	3025-100R (TH)	72
169HR/2	275	2000Z	22	2440A	41	3025-T35	71
169WM	274	2001A	251	2440M	41	3025Z	28
1700C	250	2001B	251	2440T	42	3027	74
1701A	251	2002A	251	24410M	261	3110A	75, 270
1701B	251	2002B	251	2441M	42	3110M	75, 270
1702A	251	2005	42	24425	261	3112G	150
1702B	251	2005Z	22	2445A	41	3112RK	301
170S	295	2010A	43	2445M	41	3116M	146
171	295	2010M	43	2450MS	38	3117M	65
17108	238	2010MZ	22	24760	262	3119	293
17108-32	238	2011M	43	2715	148	3127	135
171B-1/2	295	2020	43	2725RK	298	3128 (L80)	135
171S	295	2025 (IP)	45	2725Z	24	3129	137
171SB-1/2	295	2025 (IPR)	45	2725Z-3/8	29	3131A	134
172	295	2025 (T)	44	2726Z	24	3132	134
17300A	237	2025 (TH)	44	2726Z-3/8	29	3137	75, 155
17300M	237	2025Z	23	2749P-1/4HF	152	3138	75, 157
17400A	236	2120	48	2749P-3/8	76	3141	75, 153
17400M	236	2127	135	2749P-5/16HF	152	3201AMW	85, 288
17405A	237	2137	45, 155	2749PS-3/8	76	3206AM	85
17405M	237	2138	45, 157	2749RK	298	3210A	85
17760	239	22300A	258	2749RK-3/8	298	3210M	85
17770	239	22300M	258	2752RK	298	3216	86
17788A	239	2233A	50	2753BRK	298	3217M	86
17799A	239	22400M	258	2753J	46	3225A	266
1801A	251	22425	258	2753JB	46	3247	72, 273
1801B	251	2251A	51	2753N	46	3250M	86
1801C	250	2251M	51	2753NB	46	3251	87
1802A	251	2254M	143	2753P	46	3252M	87
1802B	251	2258M	51	2753PB	46	3275	87
1802C	250	2259M	52	2753PS	46	3277	87
180M	152	2263A	52, 288	2753RK	298	3278	87

Numerical Index

3285Z	32	3749SBRK-1/2	299	4110M	270	4715SL	149
3285ZA	32	3749SRK-1/2	299	4111M	270	4725RK	299
3285ZE	32	3751J	266	4112G	150	4725Z	33
3286Z	31	3751N	266	4112N	150	4747	111
3300A	59	3752J	77	4112RK	301	4749J	107
3300C	264, 265	3752N	77	4117M	95	4749N	107
3300CB	264	3752RK	298	4122	268	4749RK	299
3300CZ	27	3753BRK	298	4127	136	4750BRK	299
3300FN	62, 268	3753J	77	4128 (L120)	136	4750J	105
3300M	59	3753JB	78	4129	137	4750JB	105
3300M (L120)	60	3753N	77	4132	134	4750N	105
3300M/4-L120	60, 273	3753NB	78	4133	268	4750NB	105
3300MZ	27	3753P	77	4137	103, 155	4750P	105
3300S	264	3753PB	78	4138	103, 157	4750PB	105
3300W	61	3753RK	298	4141	103, 153	4750RK	299
3300X	58	3753SM	76	4202	271	4752J	104
3300XA	58	3753SMB	76	4203M	133	4752N	104
3300XZ	26	3755	81	4203MF	133	4752RK	299
3305A	59	3755RK	300	4211A	130	4753BRK	299
3305M	59	3756	81	4211M	130	4753J	106
3305M (L120)	60	3756Z	31	4214M	130	4753JB	106
3305M/4-L120	60	3756ZS	31	4223M	112	4753N	106
3305P	264, 265	3757	81	4238AM	112, 288	4753NB	106
3305PZ	27	3760	82	4241A	113	4753P	106, 107
3305W	61	3760Z	30	4241M	113	4753PB	106
3305X	58	3762	81	4249M	113	4753RK	299
3305XA	58	3763	82	4250M	113	4755	108
3310M	60	3768J	83	4251A	114, 288	4755RK	300
3322A	84	3768P	83	4251M	114	4756	108
3322AZ	31	3768RK	300	4252M	114	4756Z	34
3325	61	3768Z	30	4254	114	4760	109
3340C	265	3768ZRK	300	4262M	114	4760Z	34
3340M	64	3769H	83	4272AM	115	4763	109
3341G	267	3769N	83, 172	4275	115	4768J	108
3342G	267	3769NWF	83, 172	4276	115	4768P	108
3344A	84	3770	84	4277	115	4768RK	300
3345P	265	3771	84	4282	272	4768Z	33
3350M	62	3771Z	31	4285Z	34	4768ZRK	300
3350M (L120)	62	3772Z	31	4285ZE	34	4770	110
3350M/2-L120	62, 273	3774J	79	4300A	93	4771	110
3350X	58	3774JB	79	4300C	264	4771Z	34
3400A	54	3774JBL	80	4300H	269	4774J	107
3400LH	56	3774JL	79	4300H (8P)	269	4774JB	108
3400M	54, 271	3774N	79	4300M	93	4774N	107
3400MZ	26	3774NB	79	4300M (L110)	278	4774NB	108
3400W	55	3774NL	79	4300M (L120)	95	4774P	107
3405A	54	3774P	79	4300M (L60)	278	4774PB	108
3405M	54	3774PB	79	4300S	264	4780	110
3405W	55	3774PL	79	4305A	93	4781N	110
3410M	55	3774PS	78	4305M	93	4785	110
3415A	56	3774P-SR	80	4310M	94	4788	111
3415M	56	3776J	80	4325	94	6012M	117
3425	56	3776N	80	4325 (L140)	95	6100M	131
3425 (2B)	57	3776P	80	4325 (L140)-2B	95	6100MRK	301
3430M	65	3780	84	4340C	265	6101	117, 276
3440A	63	3785	84	4400A	89	6102M	282
3440M	63	4000 (PH)	96	4400LH	92	6112	150
3440T	64	4000 (PZ)	96	4400M	88	6112RK	301
3441M	64	4005	96	4400M (DU)	286	6201A	121
3445A	63	4010A	97	4400MZ	33	6201M	121
3445M	63	4010M	97	4400W	90	6212M	121
3445W	63	4010M (12P)	269	4401M	88	6300A	117
3450M	57	4012A	99	4405A	89	6300M	117
3701	266	4012M	98, 286	4405M	88	6305A	117
3715	148	4020	100	4405M (DU)	286	6305M	117
3715S	148	4020 (MH)	270	4405W	90	6400A	116
3715SL	148	4025 (IP)	101	4406M	88	6400M	116
3715SLK	148	4025 (T)	101	4410M	90	6405A	116
3716	148	4025-T35	102	4425	91	6405A (MV)	286
3725RK	298	4027	102	4425 (EPL)	91	6405M	116
3725Z	29	4100A	130	4425-N	90, 275	6425	116
3725ZS	29	4100ARK	301	4433A	111	6644A	120
3726Z	30	4100M	130	4440A	96	6688A	120
3726ZS	30	4100MRK	301	4440M	96	6749	118
3749BRK	298	4101	103, 276	4440T	96	6749-HEAD	118
3749RK	298	4102	271	4450M	92	6749RK	299
3749S	76	4103M	133	4466A	111	6752	118
3749S-1/2	104	4104	132	4711X	149	6752-HEAD	118
3749SB	76	4109M	270	4715	149	6752RK	299
3749SB-1/2	104	4110A	270	4715S	149	6755	119

6755RK	300	NV13760	245	RS2300A/9	39	RS3405M/12	54
6760	119	NV14134	247	RS2300M/11	39	RS3405W/7	55
6768	119	NV14145	248	RS2300MZ/12	21	RS3410M/12	55
6768-HEAD	119	NV14400	248	RS2300X/11	38	RS3425/4 (2B)	57
6768RK	300	NV14433A	248	RS2300XZ/9	21	RS3425/9	56
6770	120	NV14760	248	RS2305A/9	39	RS3430M/6	65
6785	120	NV16400	249	RS2305M/11	39	RS3440A/8	63
6788	120	NV16760	249	RS2310M/11	40	RS3440M/8	63
8012M	123	P2201AM	53	RS2350M/4	41	RS3440T/8	64
8102M	282	P2251M	53	RS2350X/4	38	RS3441M/5	64
8225M	126	P2258M	53	RS2400A/9	36	RS3445W/7	63
8400A	122	P2285Z	25	RS2400M/11	36	RS3450M/8	57
8400M	122	P4241M	112	RS2400MZ/12	21	RS3X00MZ/12	27
8405A	122	PIPE	118, 119, 124	RS2400W/9-BA	36	RS4010A/10	97
8405M	122	PK1301C	250	RS2405A/9	36	RS4010M/10	97
8749	124	PK1302C	250	RS2405M/11	36	RS4012A/10	99
8749-HEAD	124	PK1401C	250	RS2410M/11	37	RS4012M/10	98
8749RK	299	PK1402C	250	RS2425/6	37	RS4020/6	100
8760	123	PK1600C	250	RS2445A/9	41	RS4025/9 (IP)	101
8768	124	PK166PS/6	170	RS2450MS/6	38	RS4025/9	101
8768-HEAD	124	PK168PS/6	171	RS3010A/8	67	RS4027/7	102
8768RK	300	PK1801C	250	RS3010M/8	67	RS4127/6	136
8770	123	PK2346/6	84	RS3010MZ/8	28	RS4129/5	137
8785	124	PK2760/6	48	RS3015M/8	69	RS4300A/10	93
8788	124	PK2763/6	48	RS3020/6	70	RS4300M/10	93
8866A	123	PK3760/6	82	RS3020/7	70	RS4300M/12	93
AG112A	151	PK3763/6	82	RS3025/8 (IP)	73	RS4305A/10	93
AG112F	151	PK4760/5	109	RS3025/8	71	RS4305M/10	93
AG112H	151	PK4763/5	109	RS3025/8-L100RH	72	RS4310M/10	94
AN112A	151	PS6	283	RS3025/8 (T)	71	RS4325/7	94
AN112C	151	PS8	283	RS3025/9 (IPR)	74	RS4400A/10	89
AN14300	278	PW6	283	RS3025/9 (TH)	72	RS4400LH/6	92
AR14300	278	PW8	283	RS3025Z/8	28	RS4400MZ/10	33
AS2305A	40	PW8L	283	RS3027/5	74	RS4400W/8	90
AS2405A	37	PW8P	283	RS3127/8	135	RS4401M/10	88
AS2445A	41	PW8P/4	283	RS3129/6	137	RS4405A/10	89
BD004	293	R810	141	RS3300A/9	59	RS4405W/8	90
BD008E (12P)	291	R810A	144	RS3300FN/6	268	RS4406M/10	88
BD011SE	291	R810B	144	RS3300FN/8	62	RS4410M/10	90
BD014E	290	R810C	144	RS3300M/12	59	RS4425/6-EPL	91
BD014E-SF	291	R810D	144	RS3300MZ/12	27	RS4425/6-N	90, 275
BD014SE	290	R810E	144	RS3300MZ/8	27	RS4425/7	91
BD014XE-SF	291	RS13012M/8	188	RS3300W/7	61	RS4450M/10	92
BD016E	292	RS13025/8	188	RS3300X/8	58	RSAL	32
BD016JE	292	RS13301X/9	182	RS3300XA/9	58	RSAL200-1/4x12	32
BD017E	292	RS13401M/9	179	RS3300XZ/12	26	RSAL200-3/8x8	32
BD018	293	RS13401MS/5	178	RS3300XZ/8	26	RSAL300-1/2x10	32
BD022	294	RS14012M/10	205	RS3305A/9	59	RSAL300-3/8x12	32
BD023E	294	RS14025/6	205	RS3305M/12	59	RSAS2305A/10	40
BD024E	294	RS14124/7	279	RS3305W/7	61	RSAS2405A/10	37
BD14400MJ	292	RS14301X/10	199	RS3305X/8	58	RSX025/11 (IP)	73
BD14410MJ	292	RS14401M/10	196	RS3305XA/9	58	RSX025/11 (IPR)	74
CLIP.P	32	RS14401MS/5	197	RS3310M/12	60	RSX425/14	56
D3753J	77	RS14405M/11	195	RS3325/9	61	S3240A	86
D4753J	106	RS2010A/8	43	RS3340M/8	64	S3240M	86
ENH2003	51	RS2010M/7	43	RS3350M/5	62	S4240A	112
ESH2001	51	RS2025/7	44	RS3350X/4	58	S4240M	112
ESH3001	85	RS2025/7 (IP)	45	RS3400A/9	54	SP4122	268
ETH3001	85	RS2025/7 (IPR)	45	RS3400LH/7	57	SP4300M	268
HA001	294	RS2025/7 (TH)	44	RS3400M/12	54	SP4305M	268
HA003	294	RS2025Z/7	23	RS3400MZ/12	26	ST4027	269
NV13134	247	RS20XXZ/9	22	RS3400MZ/8	26	Ti4261M	128
NV13145	245	RS2127/10	135	RS3400W/7	55		
NV13400	245	RS2127/6	135	RS3405A/9	54		

Reproduction in whole or in part without proper and prior authorization is prohibited.
Der Nachdruck, im ganzen oder auch auszugsweise, bedarf unserer ausdrücklichen, vorherigen Genehmigung.
La reproduction de ce catalogue en tout ou en partie sans autorisation préalable est interdite.

本商品目錄之全部版權,係歸於株式會社山下工業研究所(KOKEN TOOL CO., LTD.)所有,不論其部分或全部,未經本公司許可,均不得複製

Koken[®]

